



# Rivian R1 Body Structure Evolution and Repairability

D. Black, M. Tummers, V. Krishnardula, D. Sosa, A. Das, J. Hasier

May 21, 2025

# Authors



**Dan Black**

Sr. Manager, Service Engineering



**Matt Tummers**

Staff Engineer, Vehicle Safety



**Venu Krishnardula**

Sr. Staff Engineer, Materials Engineering



**Abhi Das**

Staff Engineer, Body Structures



**David Sosa**

Manager, 3P Service & Collision R&D Workshop



**John Hasier**

Sr. Manager, Materials Engineering



# Safety



# Vehicle Safety at Rivian

IIHS Top Safety Pick and Top Safety Pick+ Award History



**2023** TOP SAFETY PICK+ ⓘ

**2023 Rivian R1S**

LARGE SUV / 4-DOOR SUV

Award applies only to vehicles built after January 2023

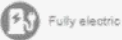

**2024** TOP SAFETY PICK ⓘ

**2024 Rivian R1S**

LARGE SUV / 4-DOOR SUV

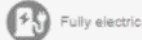

**2025** TOP SAFETY PICK+ ⓘ

**2025 Rivian R1S**

LARGE SUV / 4-DOOR SUV

Award applies only to vehicles built after August 2024



IIHS adds updated side test and updates TSP and TSP+ award criteria

IIHS adds updated moderate overlap test and updates TSP+ award criteria

IIHS updates TSP and TSP+ award criteria

**2022** TOP SAFETY PICK+ ⓘ

**2022 Rivian R1T**

LARGE PICKUP / CREW CAB PICKUP



**2023** TOP SAFETY PICK+ ⓘ

**2023 Rivian R1T**

LARGE PICKUP / CREW CAB PICKUP



**2024** TOP SAFETY PICK+ ⓘ

**2024 Rivian R1T**

LARGE PICKUP / CREW CAB PICKUP



**2025** TOP SAFETY PICK ⓘ

**2025 Rivian R1T**

LARGE PICKUP / CREW CAB PICKUP



# IIHS SORB Strategy

- Orange Offensive Structure
- Blue Defensive Structure

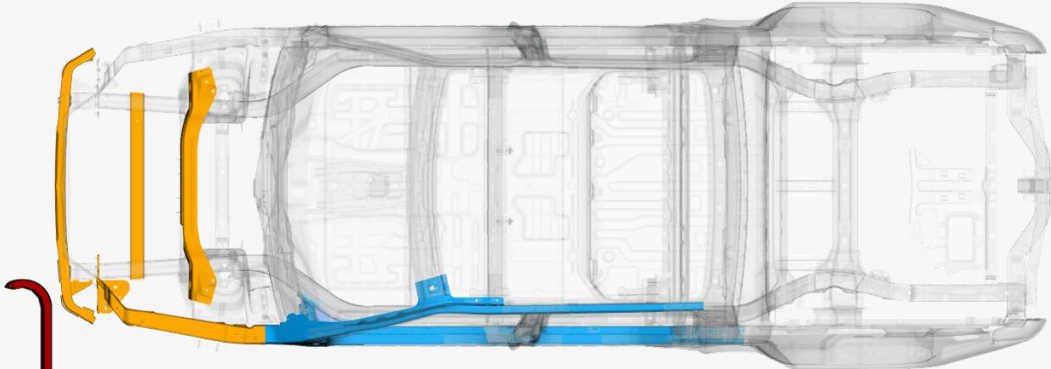
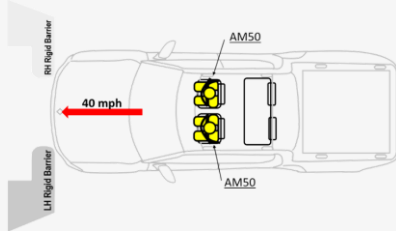

Cross-members provide lateral support for offensive structure

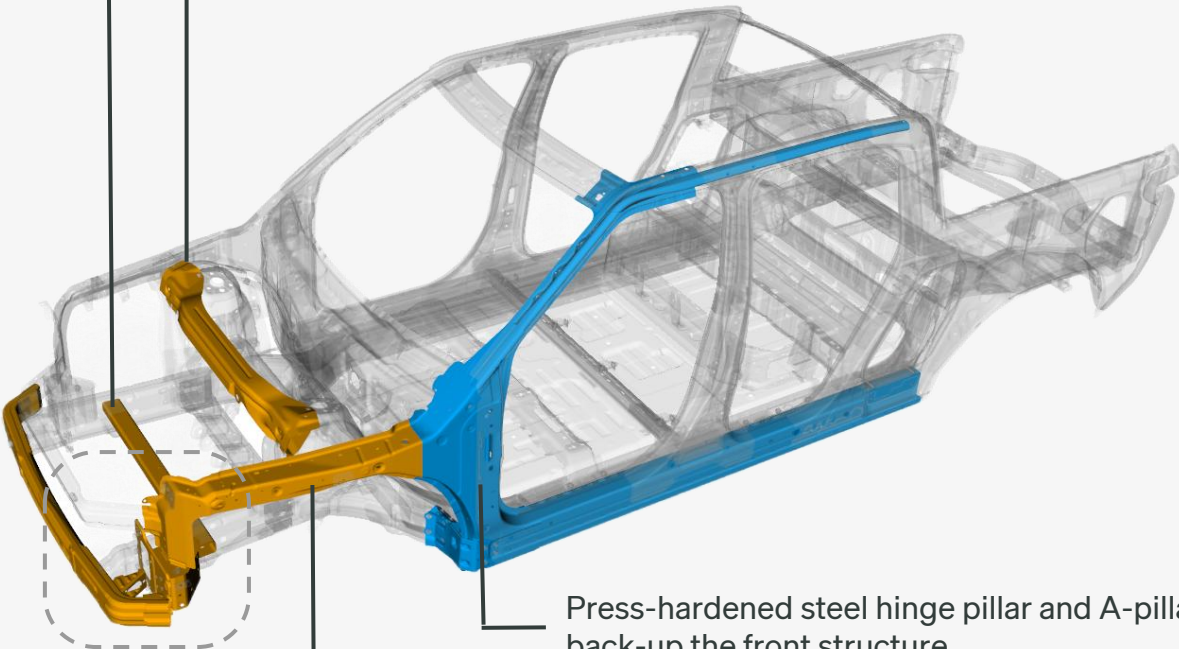

Press-hardened steel hinge pillar and A-pillar back-up the front structure

Reinforced shotgun guides the vehicle away from the barrier

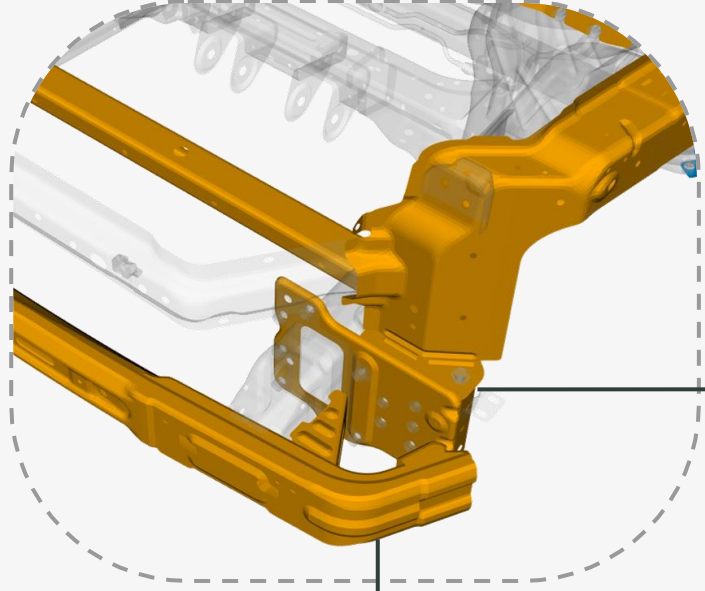

Extruded aluminum crush section provides offensive loads

Reinforced steel bumper beam extends 240 mm past crush cans



# IIHS SORB Strategy

Offensive Structure

- Orange square: Offensive Structure
- Blue square: Defensive Structure

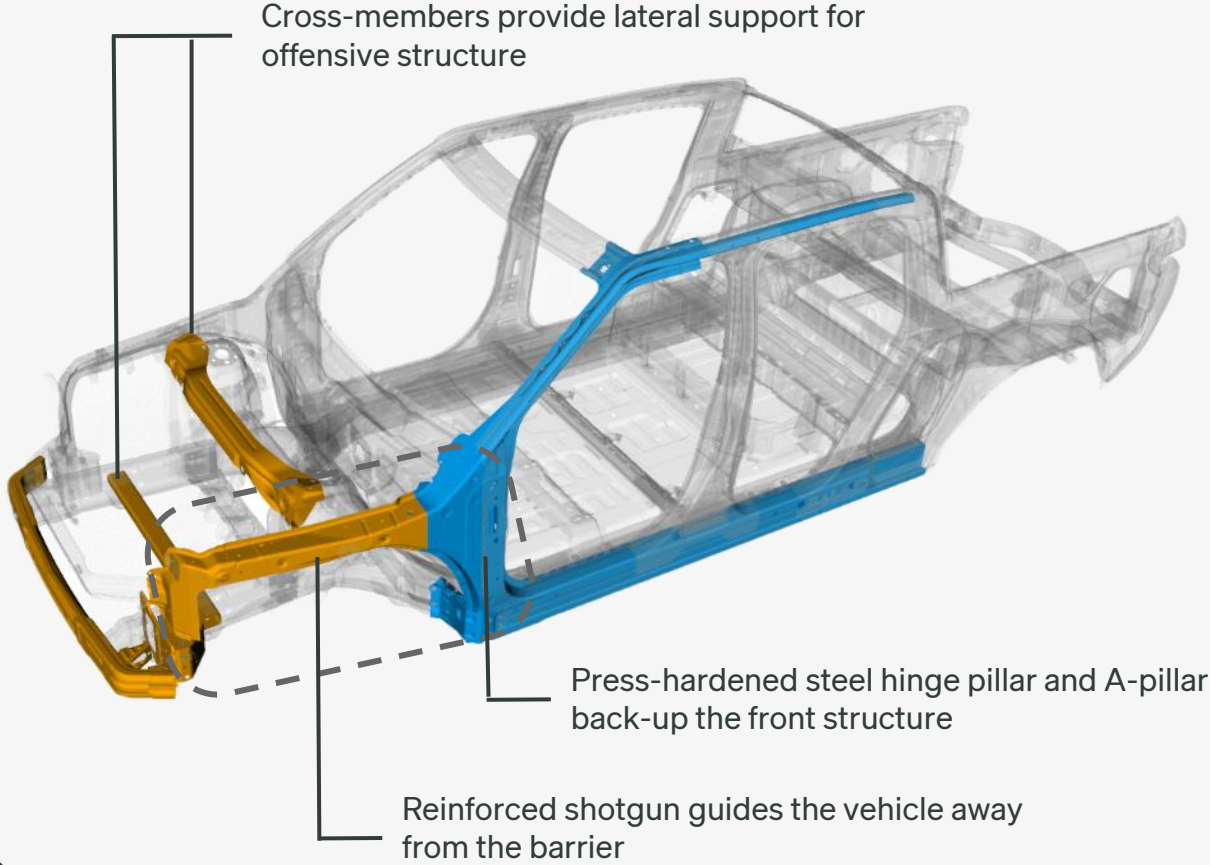

Shotgun Reinforcement and Hinge Pillar PHS

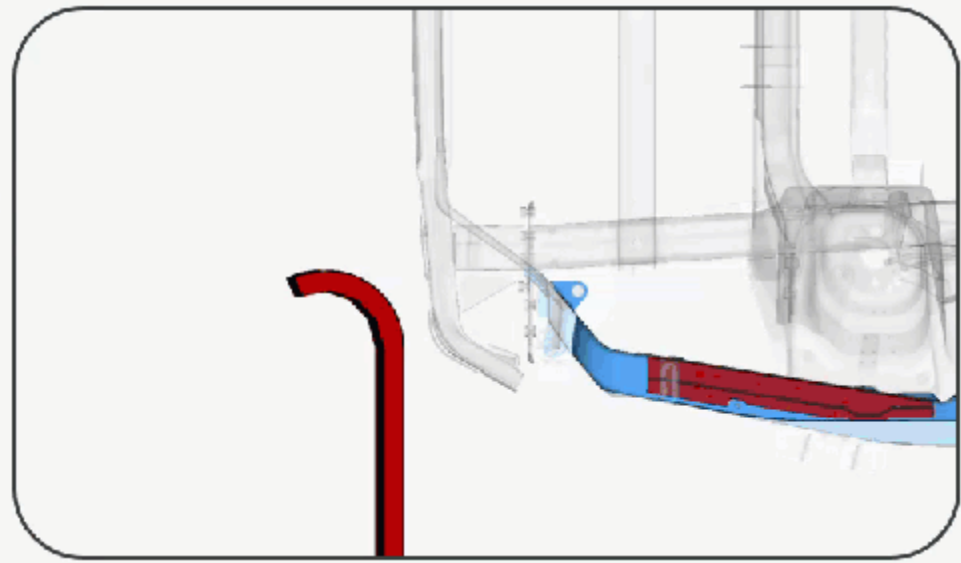
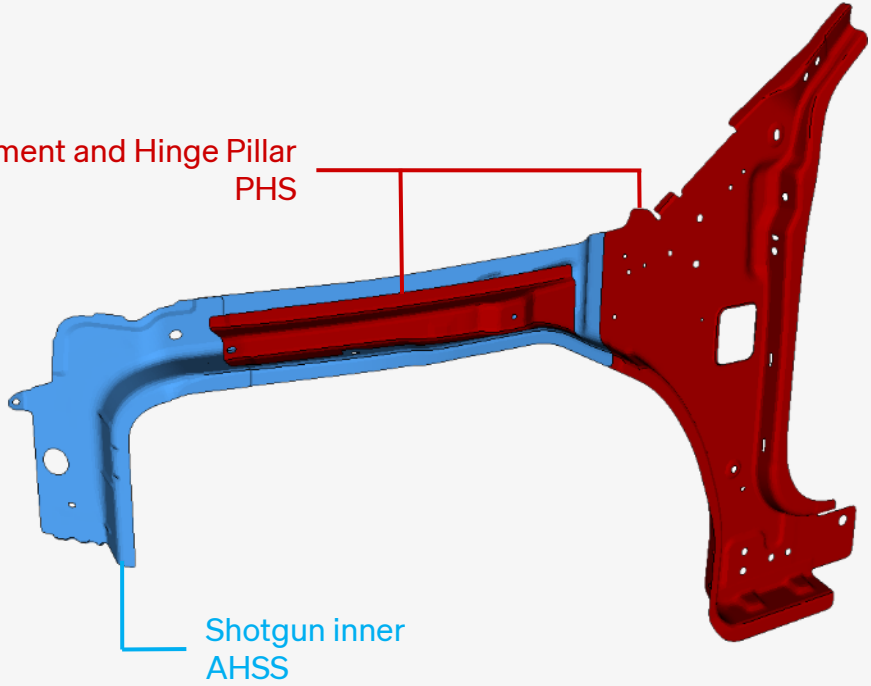

# Body Structure Evolution

Aluminum to Steel Floor Assembly

**Gen1**

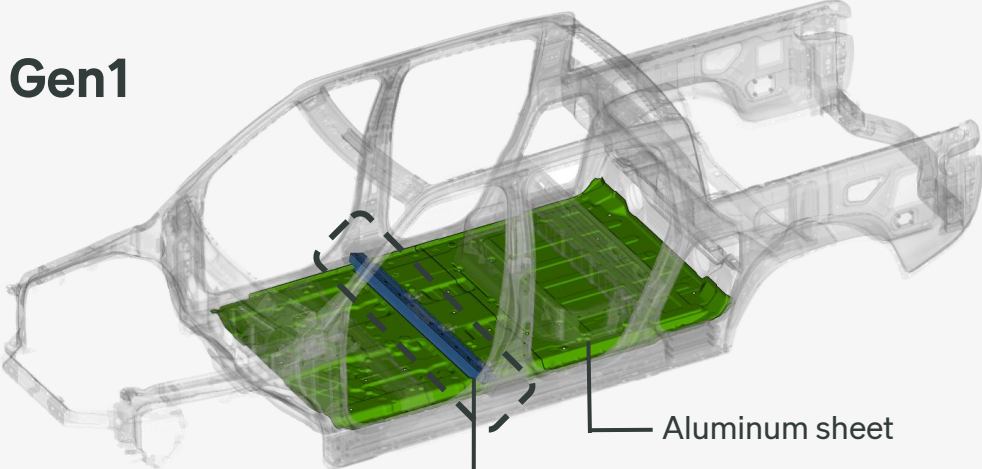

**Gen2**

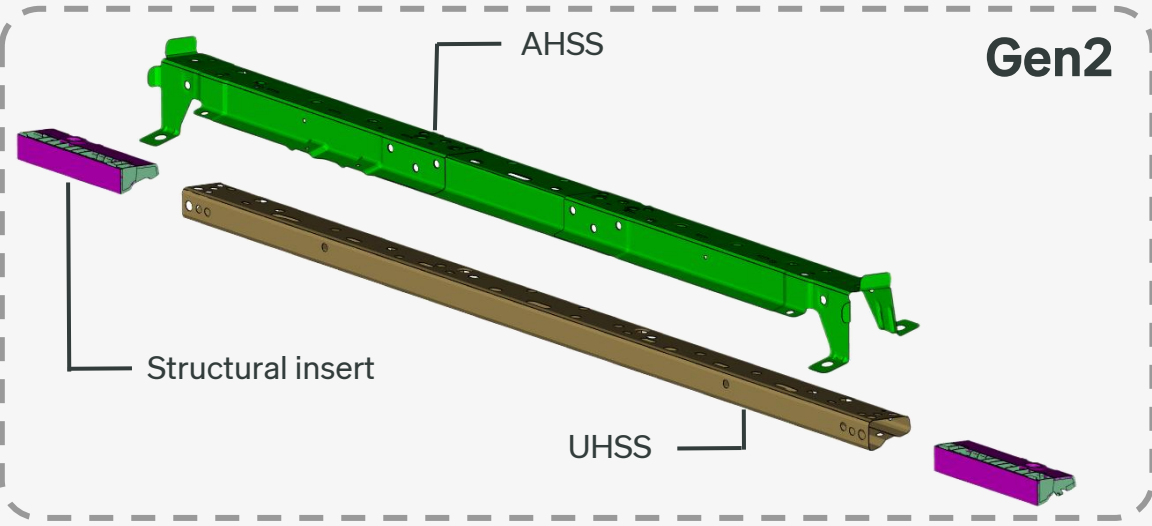
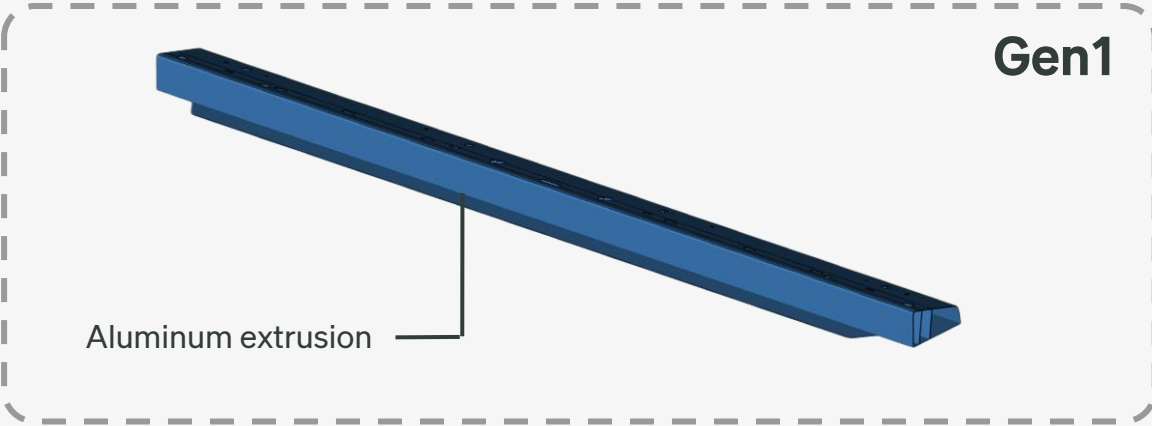
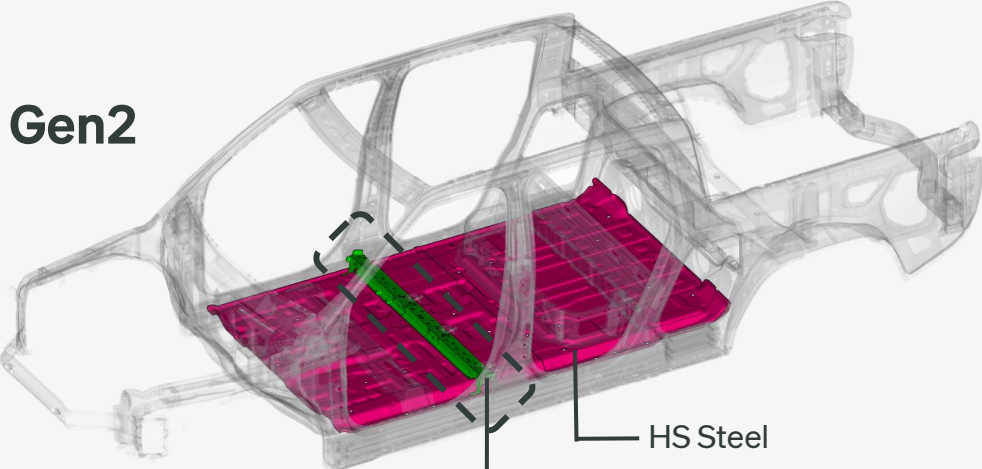

Cost Impact

Mass Impact

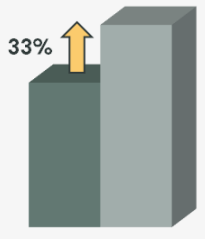
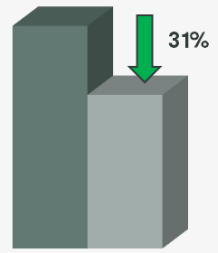

= \$15/ kg savings



# Body Structure Evolution

Side Crash Energy Management

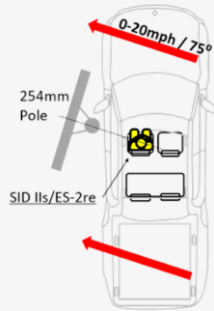

FMVSS 214 50th pole position side crash energy management

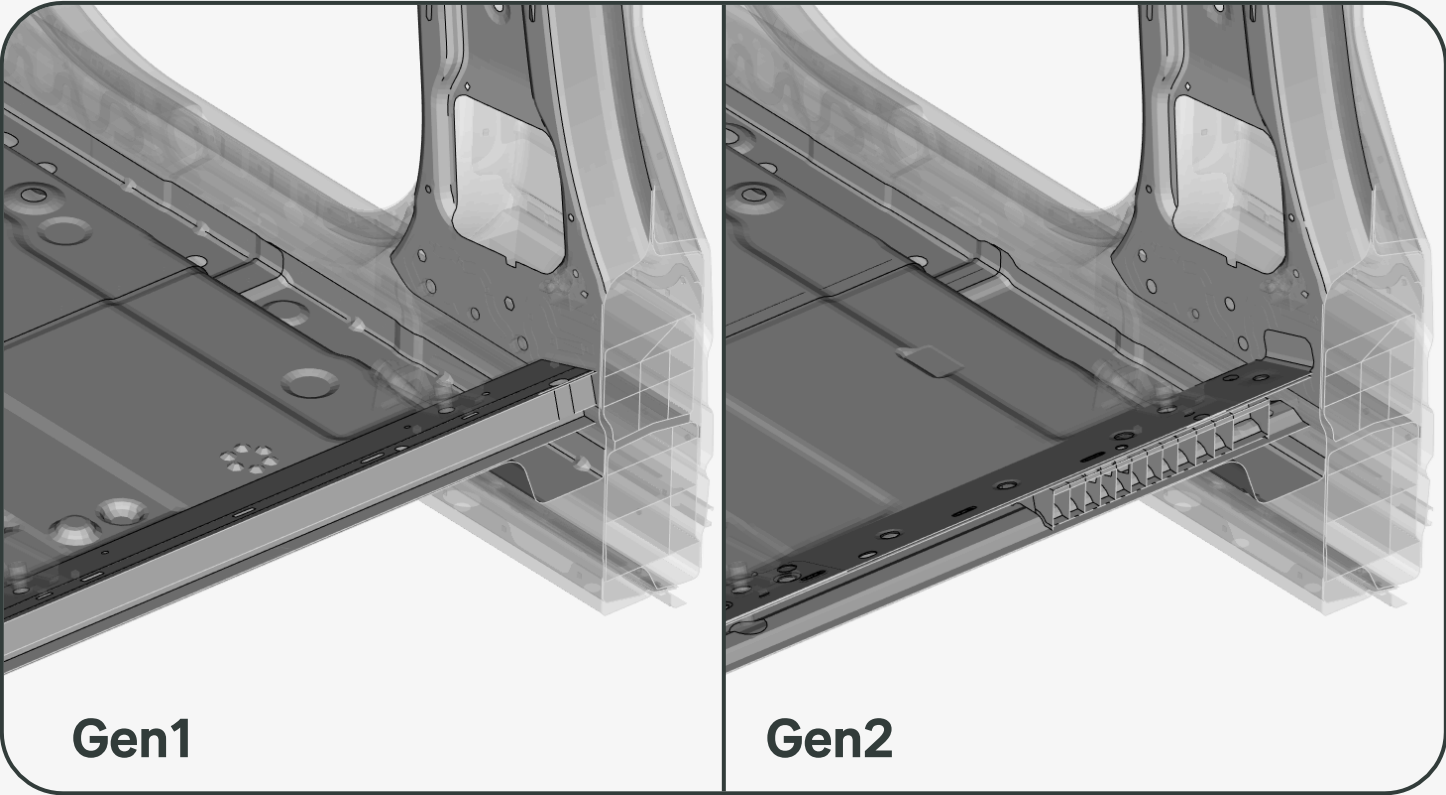
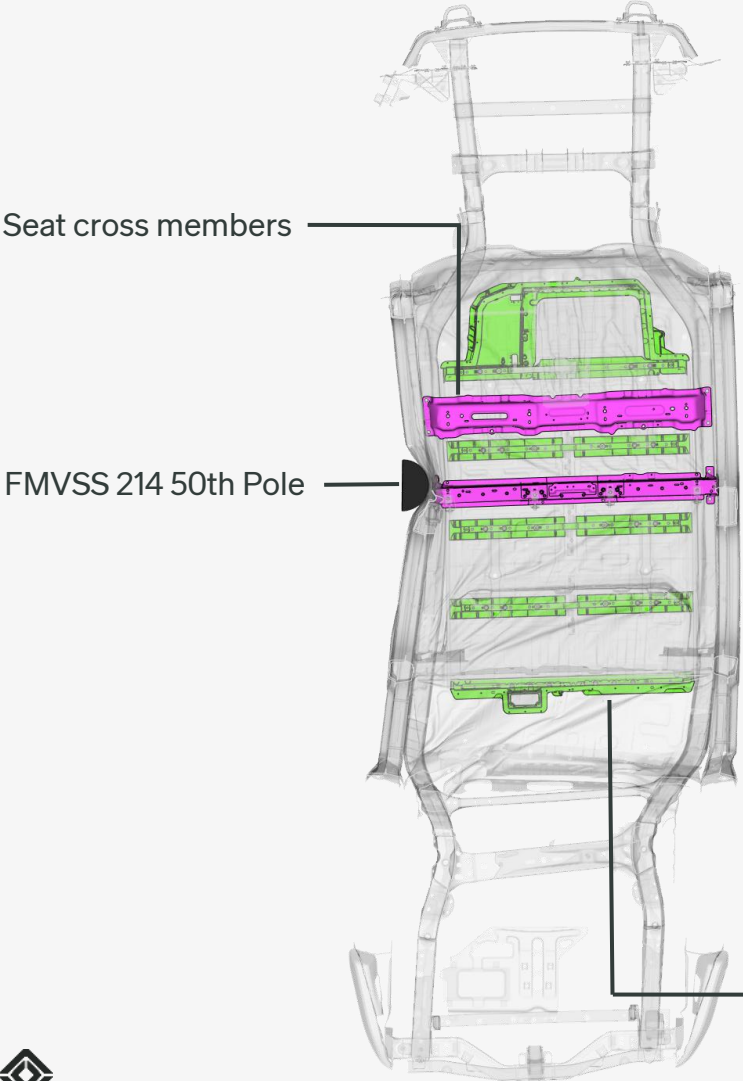

# Body Structure Evolution

Frame Joining Optimization

## Gen1

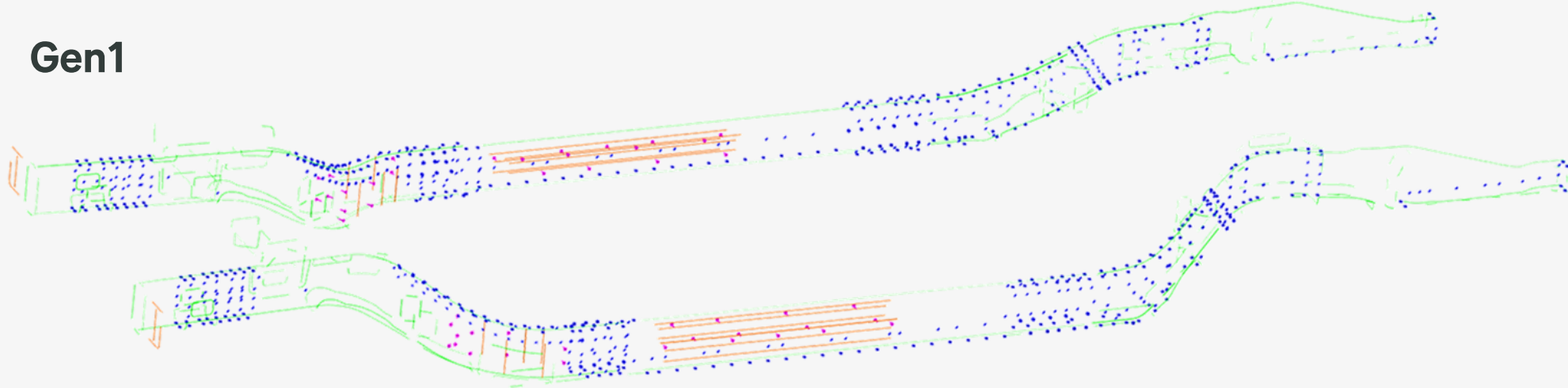

## Gen2

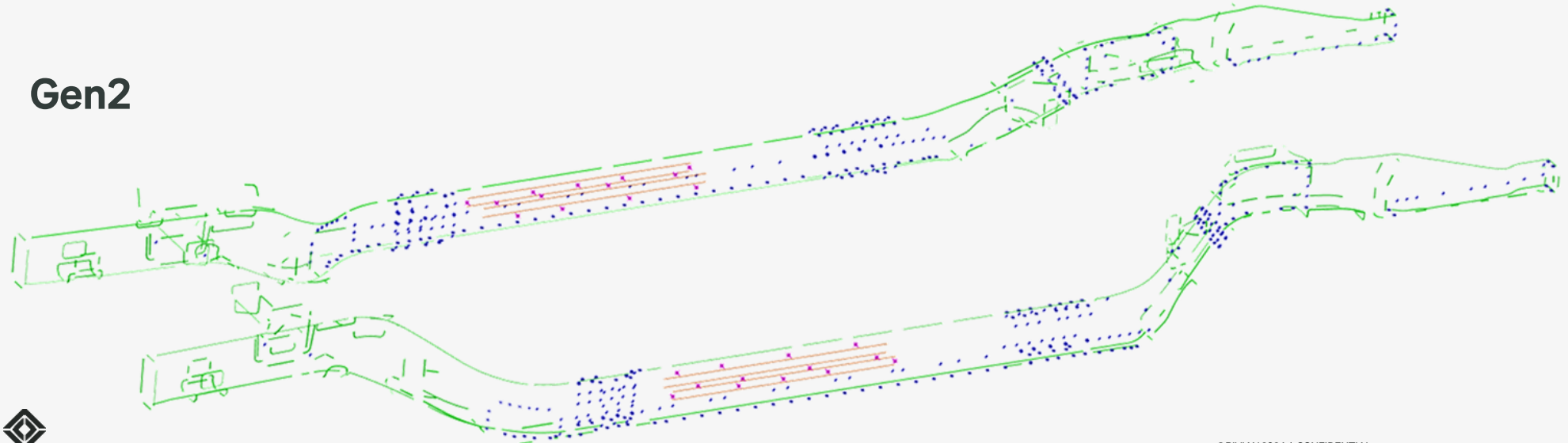

### Joining reduction / frame

RSW	300+
GMAW	8000+ mm
FDS	20+
Structural adhesive	5000+ mm
DA stud	10+

### How did we achieve it ?

- By consolidating parts using technologies like Tailor Rolled Blank (TRB)
- By using structural composite inserts to reduce joining requirements
- By re-assessing attribute requirements

Frame Mfg.  
Line Output

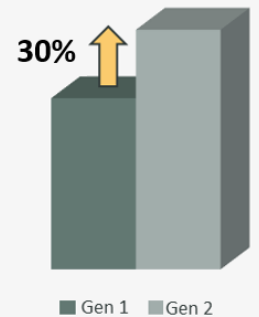

# Body Structure Evolution

Frame Cost Reduction and Part Consolidation

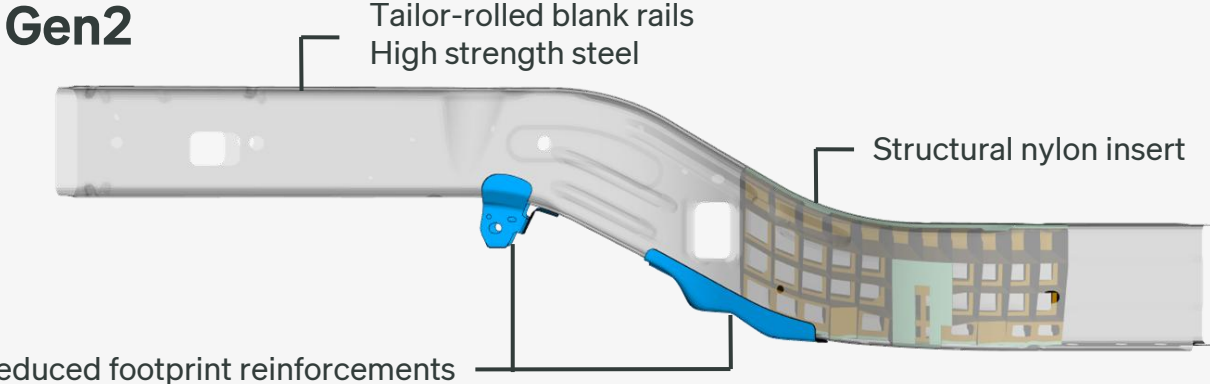
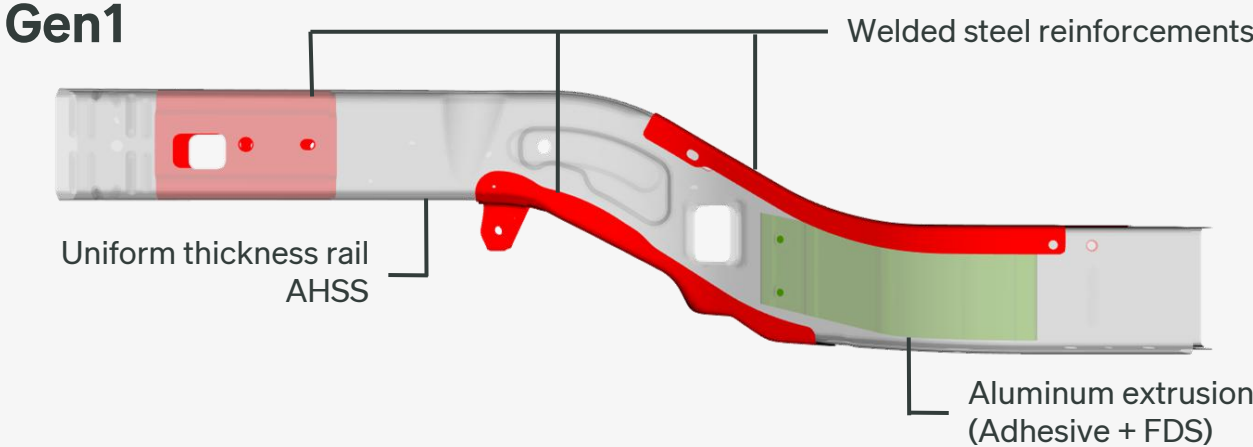

Cost Impact

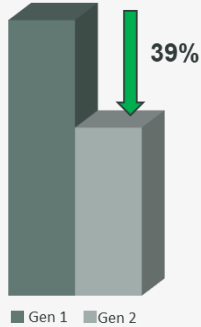

Mass Impact



How were we able to reduce the amount of welded steel reinforcements in Gen2?

- Tailor-rolled blank (TRB) technology allowed for thickness of the rail to be increased in locations where reinforcements typically would have been needed.

Rivian's R1 Gen2 TRB Rails

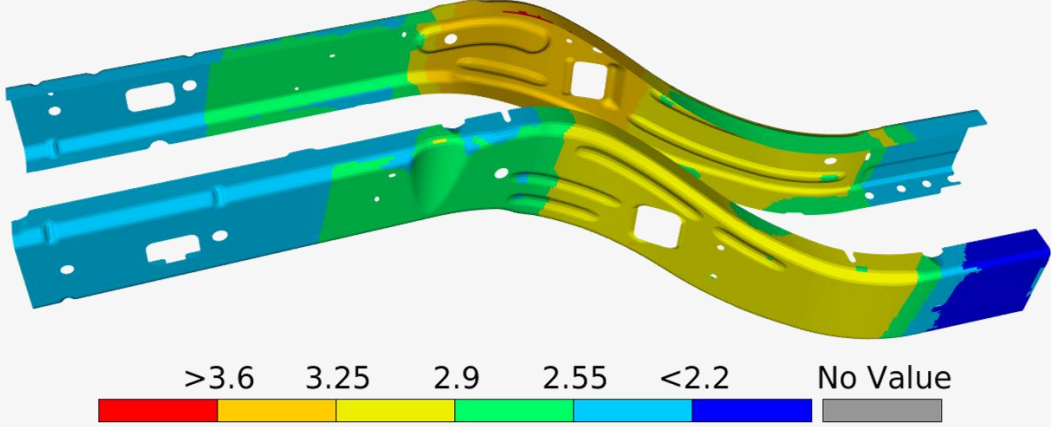

# Body Structure Evolution

Frontal Crash Energy Management

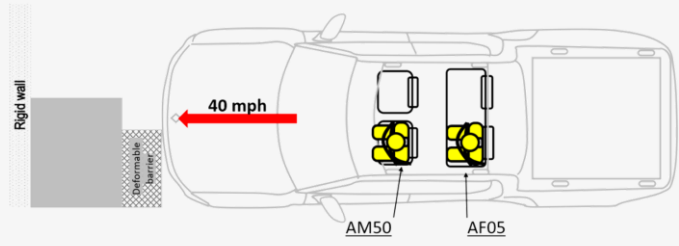
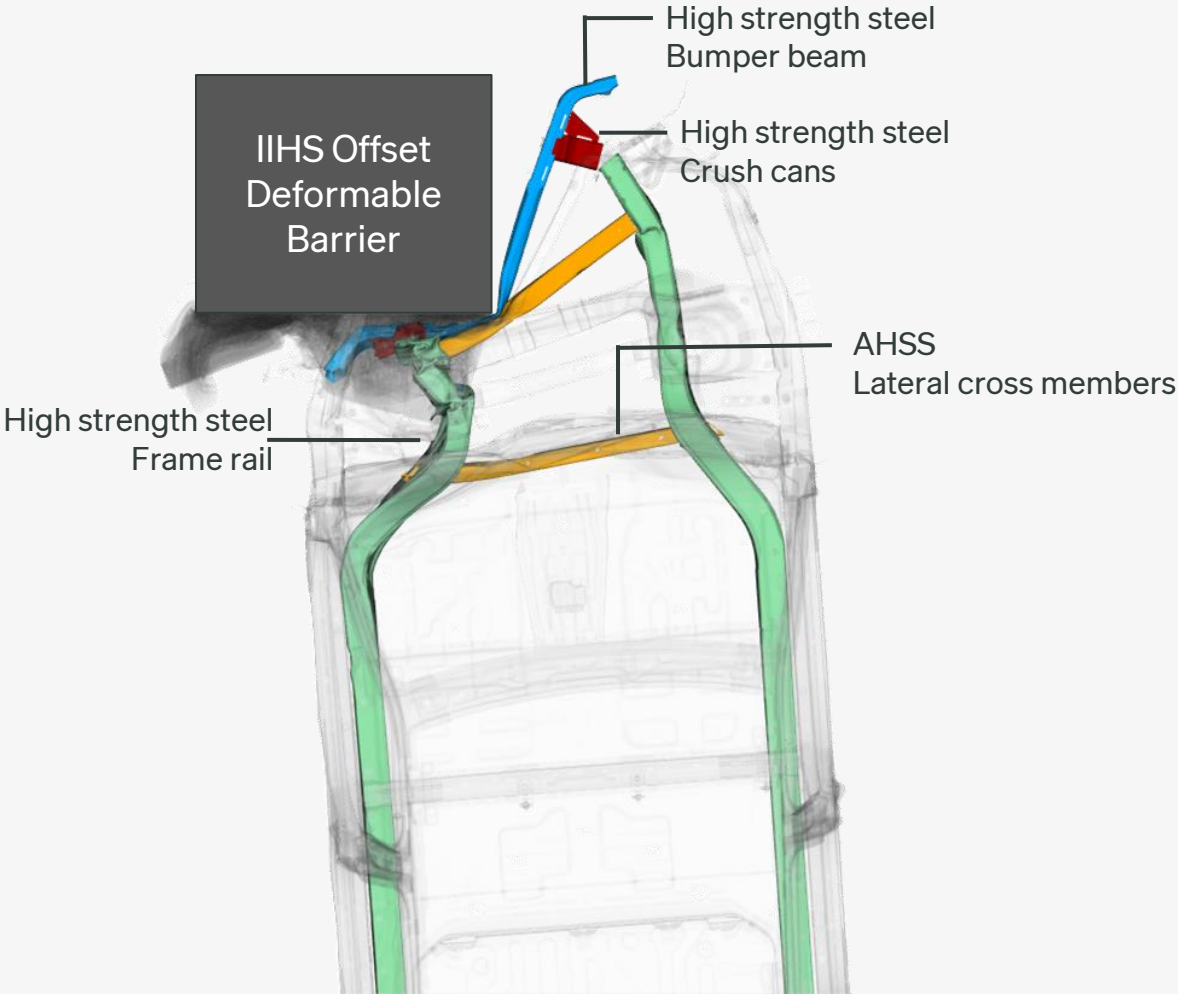

IIHS 40 mph offset deformable barrier crash energy management

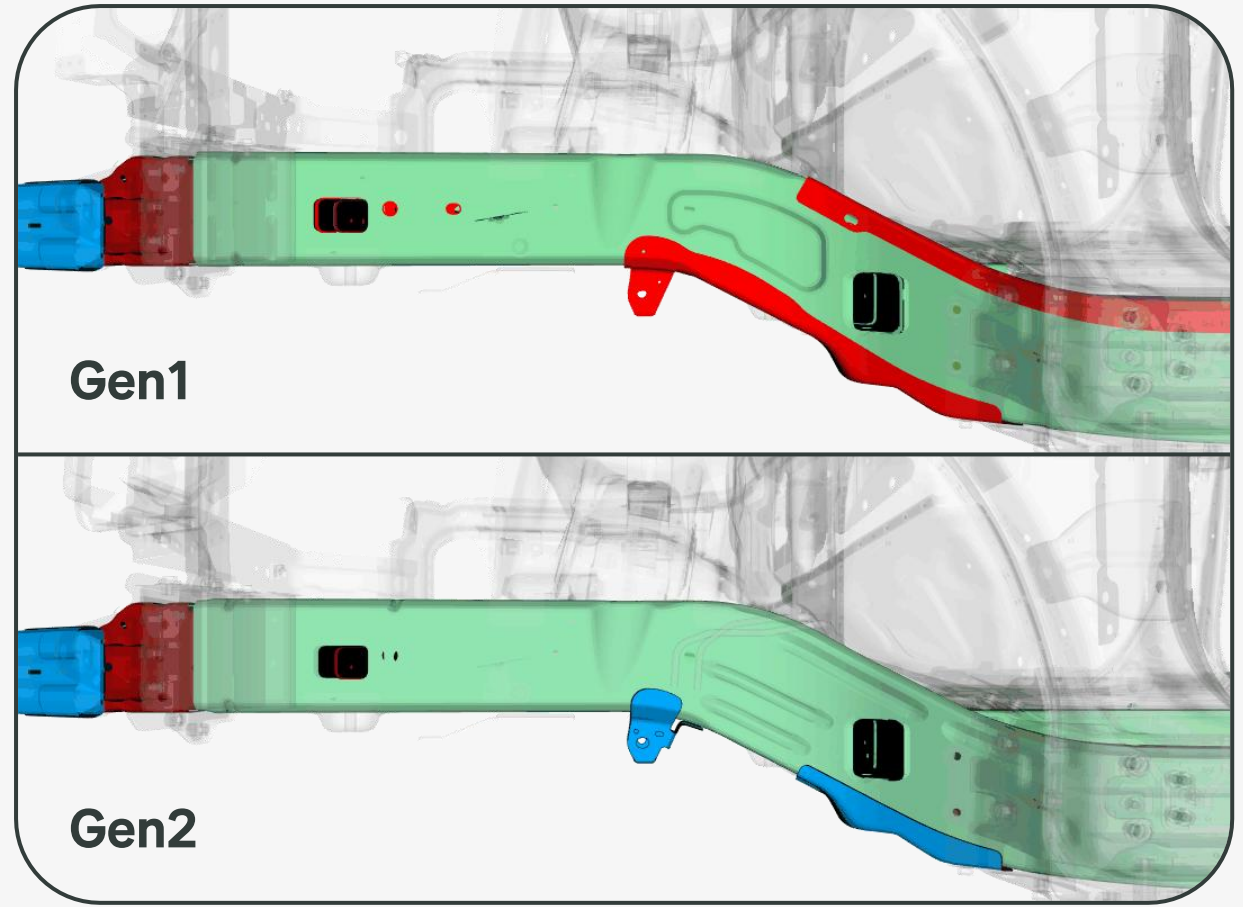

# Collision Repair



# Material Matrix

R1T- Tophat

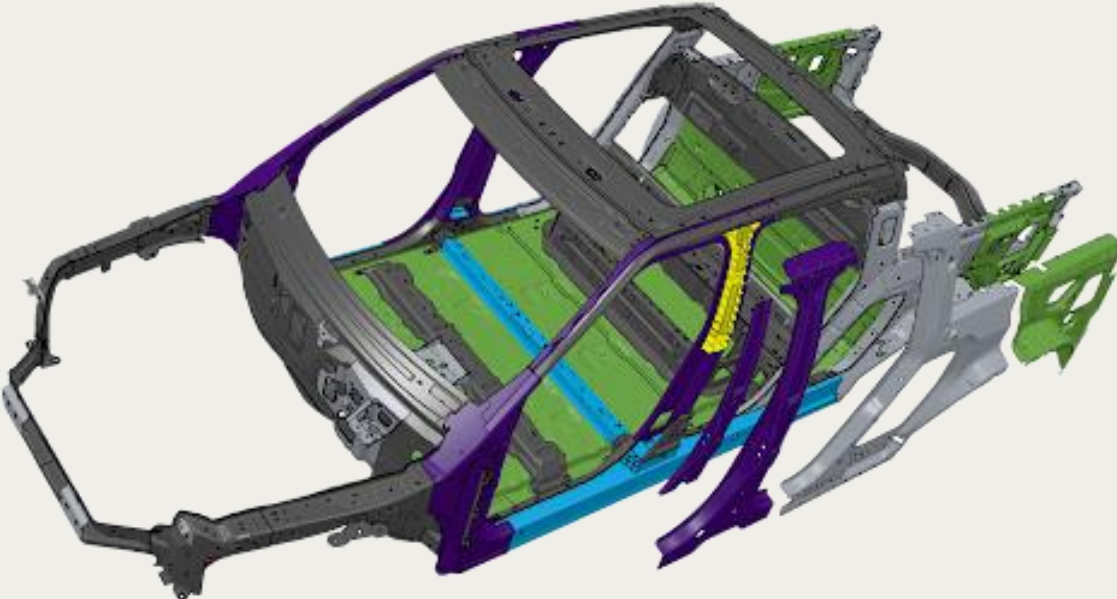

Gen 1

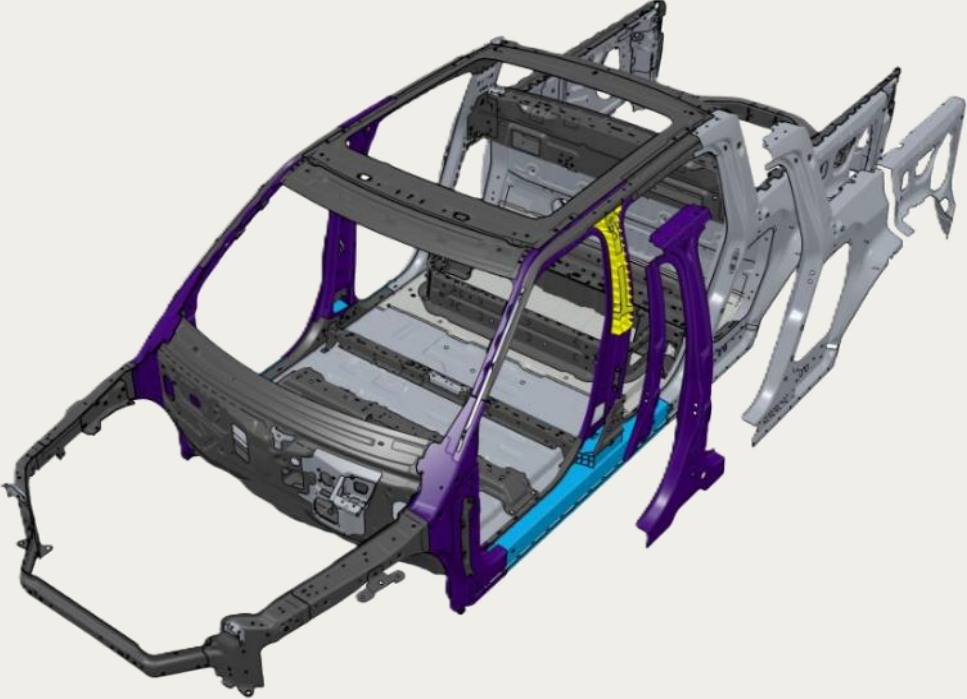

Gen 2

- Conventional Steel
- Advanced High Strength Steel
- Press Hardened (Hot Stamped) Steel
- Aluminum Sheet
- Aluminum Extrusion



# Material Matrix

R1S- Tophat

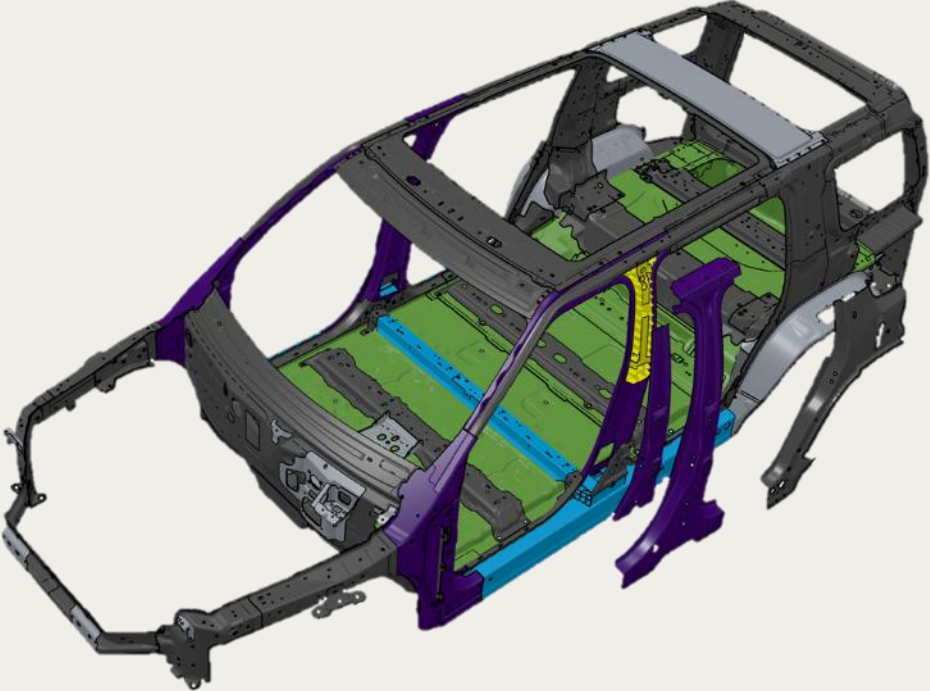

Gen 1



Gen 2

- Conventional Steel
- Advanced High Strength Steel
- Press Hardened (Hot Stamped) Steel
- Aluminum Sheet
- Aluminum Extrusion



# Material Matrix

## R1T Frame Dimensions

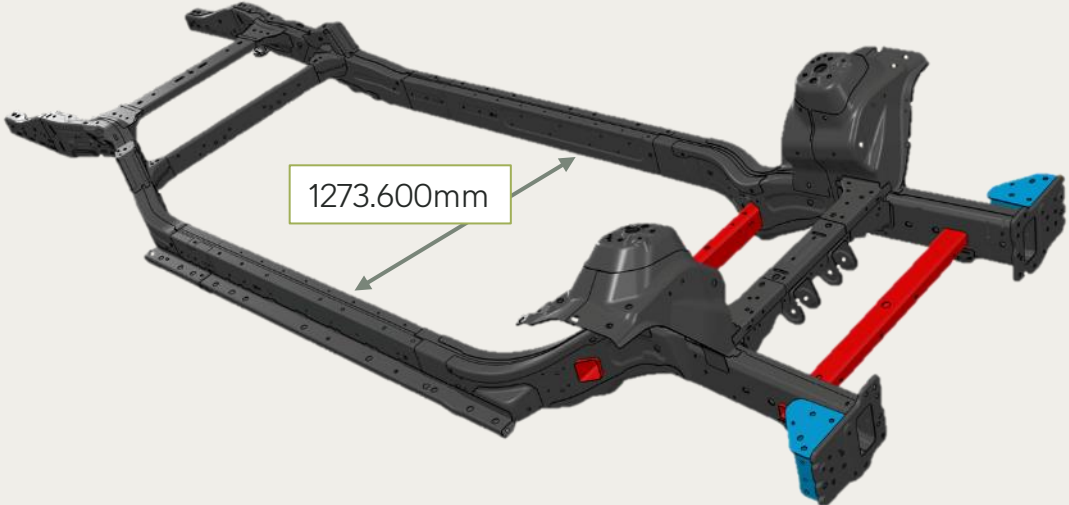

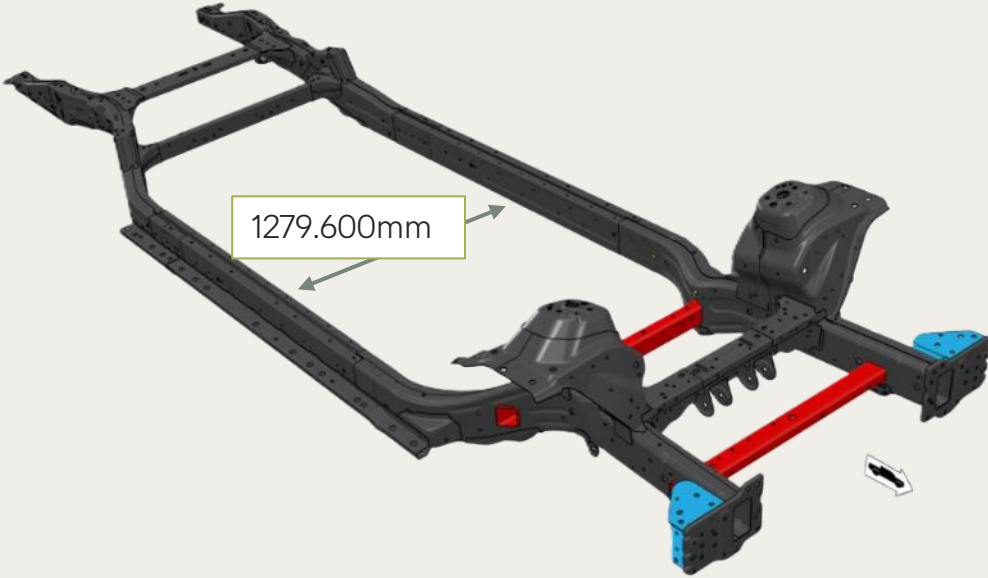

Gen 1





Gen 2

- 6mm Variance
- Gen 2 Battery Pack Provisions

 Conventional Steel

 Advanced High Strength Steel

 Ultra High Strength Steel

 Aluminum Extrusion



# Material Matrix

## R1S Frame Dimensions

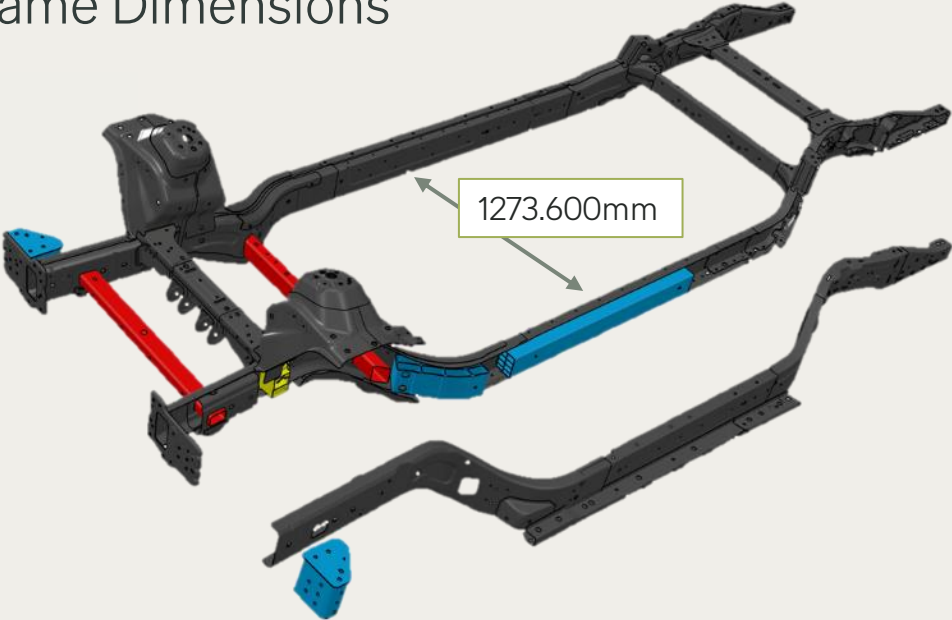

Gen 1

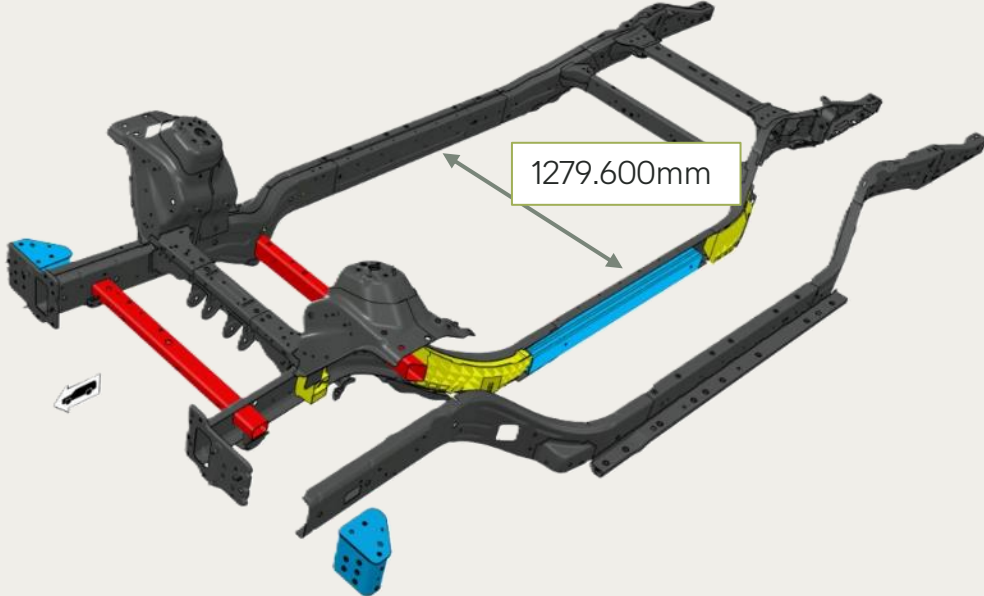

Gen 2

Conventional Steel

Advanced High Strength Steel

Ultra High Strength Steel

Aluminum Extrusion

Composite



# Collision Repair Development

Problem Statement

## Background

Frame rail damage can occur in low/moderate speed impacts

## Problem Statement

Rivian must develop repair solutions for when this type of damage occurs

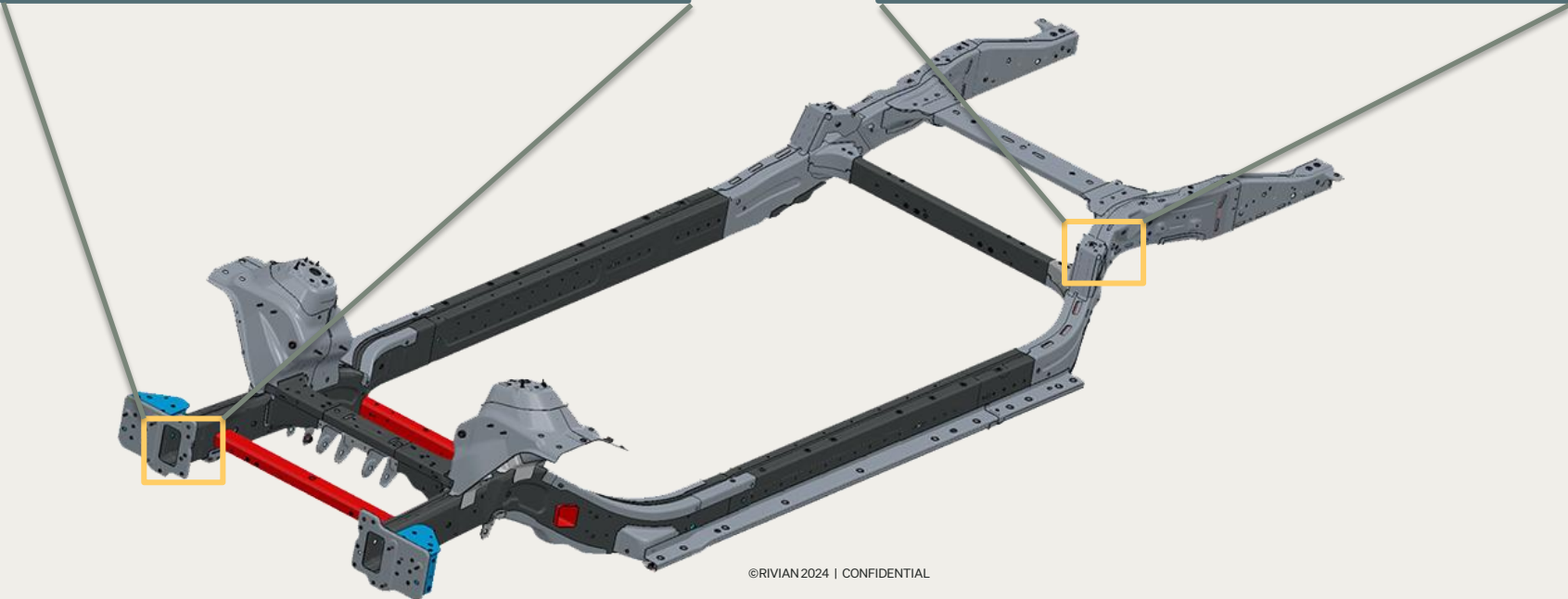
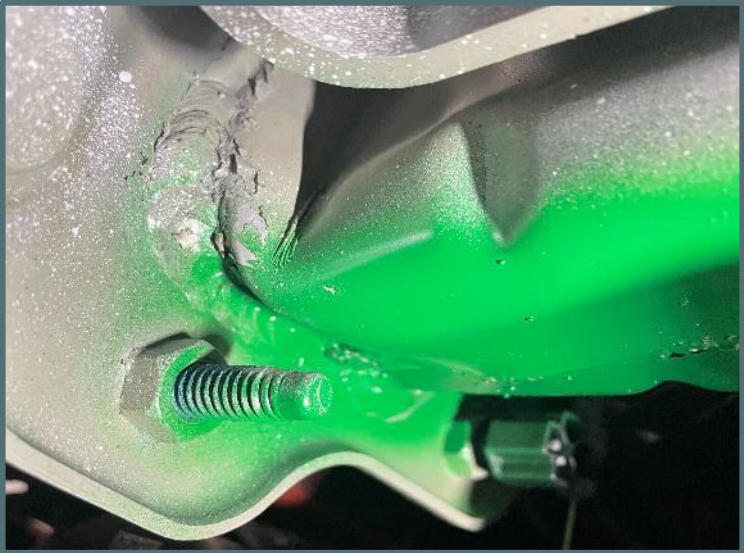

# Collision Repair Development

## Front & Rear Frame Rail Procedure

Repair Concept

CAE Validation

Component Testing

CAE Correlation

Durability Validation

Prototype Fabrication

Repair Process  
Validation

Service Part  
Finalization

Final Design  
Approval

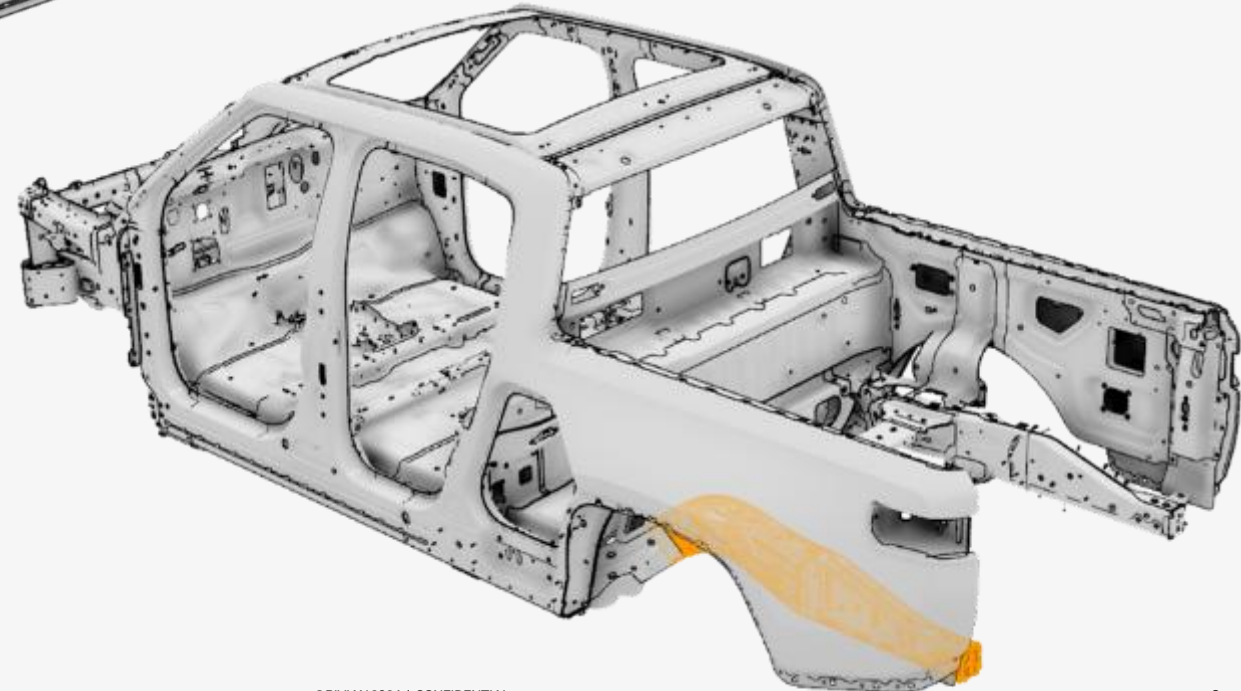
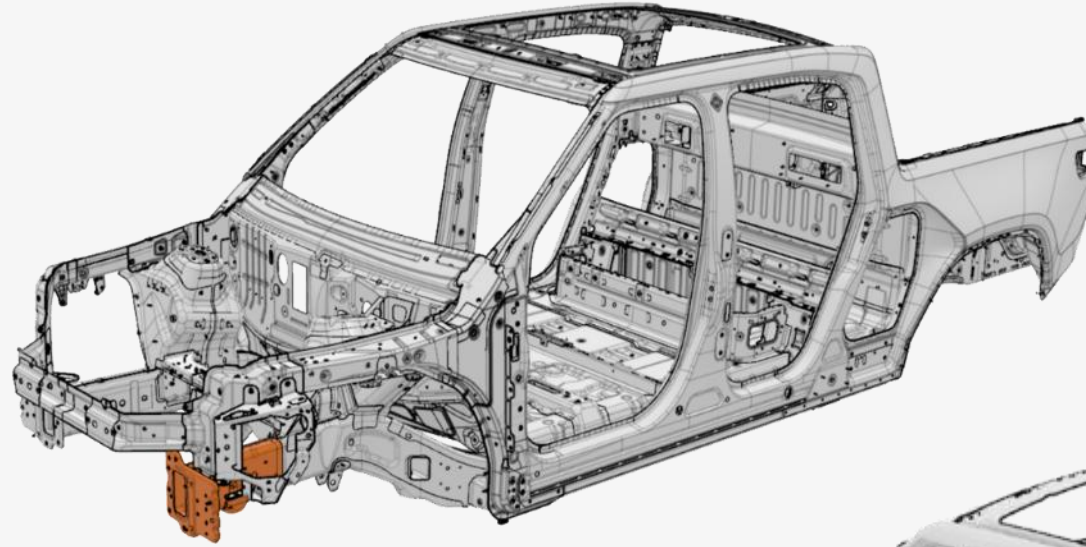

# Collision Repair Development

Front & Rear Frame Rail Procedure

**Repair Concept**

CAE Validation

Component Testing

CAE Correlation

Durability Validation

Prototype Fabrication

Repair Process Validation

Service Part Finalization

Final Design Approval

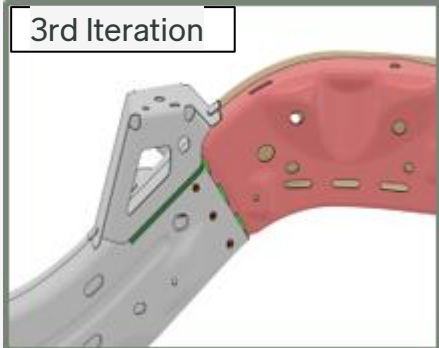
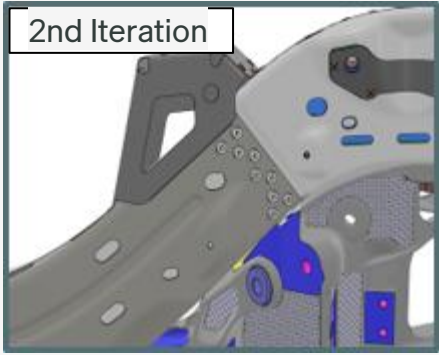
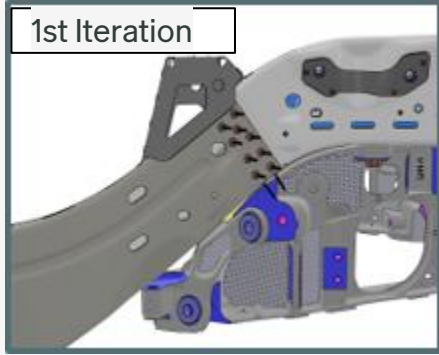
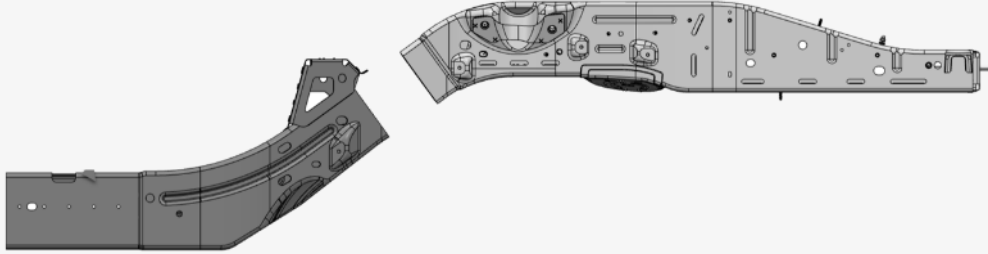
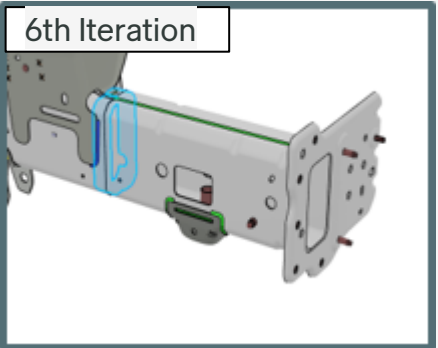
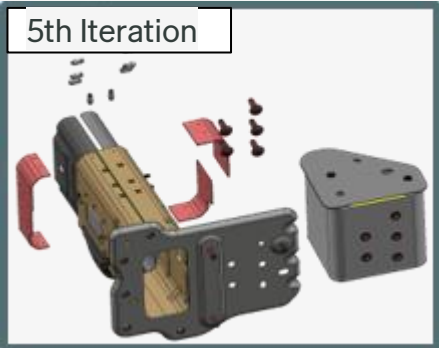
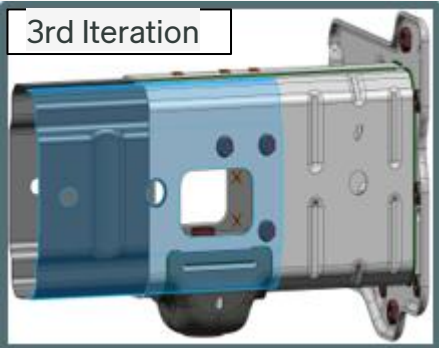
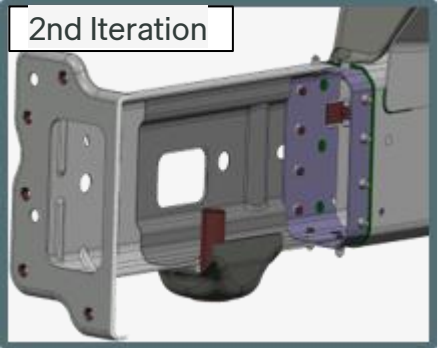
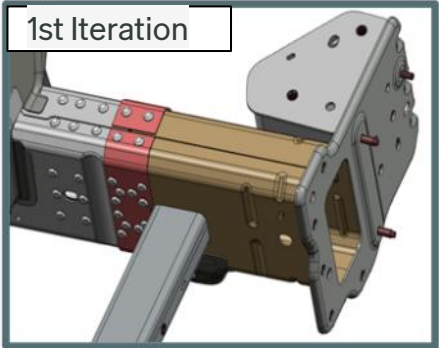

# Collision Repair Development

Front & Rear Frame Rail Procedure

Repair Concept

**CAE Validation**

Component Testing

CAE Correlation

Durability Validation

Prototype Fabrication

Repair Process Validation

Service Part Finalization

Final Design Approval

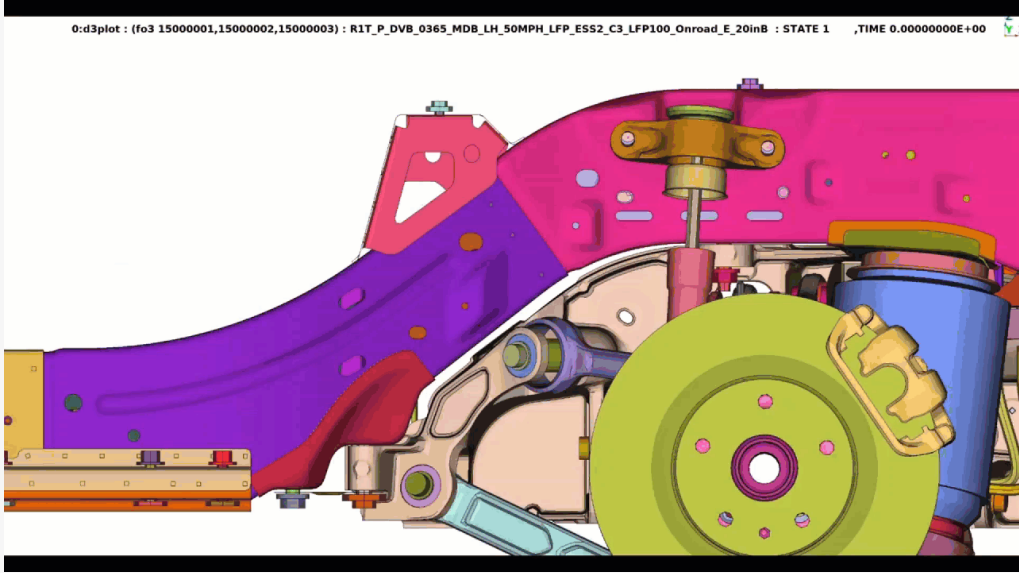
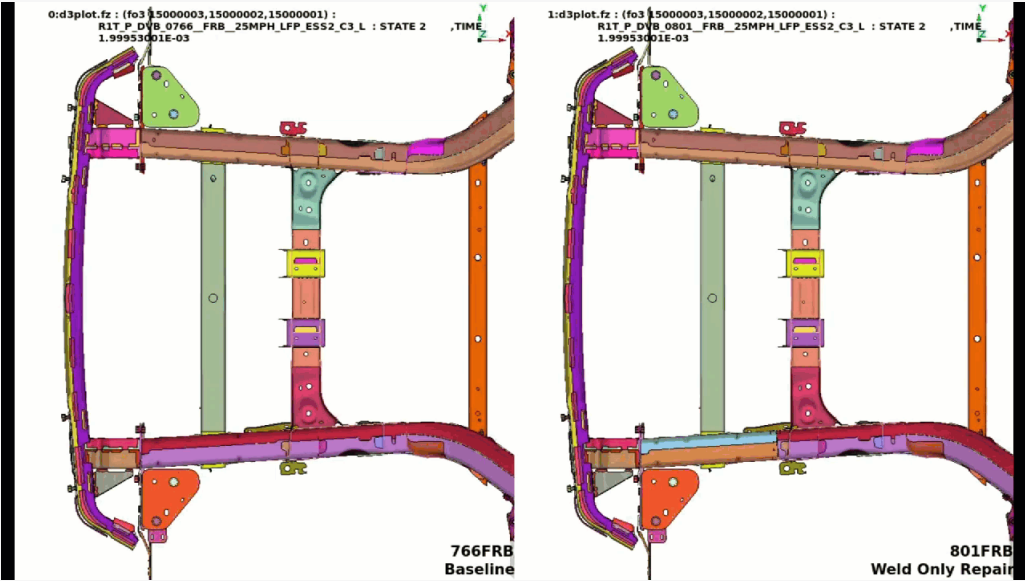

# Collision Repair Development

Front & Rear Frame Rail Procedure

Repair Concept

CAE Validation

**Component Testing**

CAE Correlation

Durability Validation

Prototype Fabrication

Repair Process Validation

Service Part Finalization

Final Design Approval

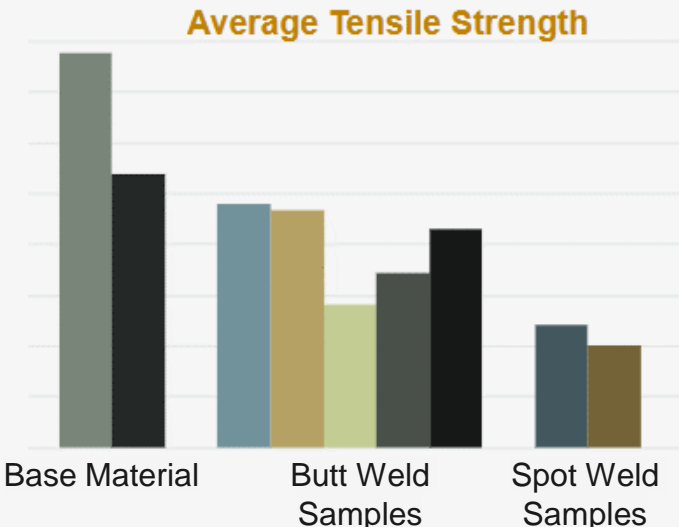

# Collision Repair Development

Front & Rear Frame Rail Procedure

Repair Concept

CAE Validation

**Component Testing**

CAE Correlation

Durability Validation

Prototype Fabrication

Repair Process Validation

Service Part Finalization

Final Design Approval

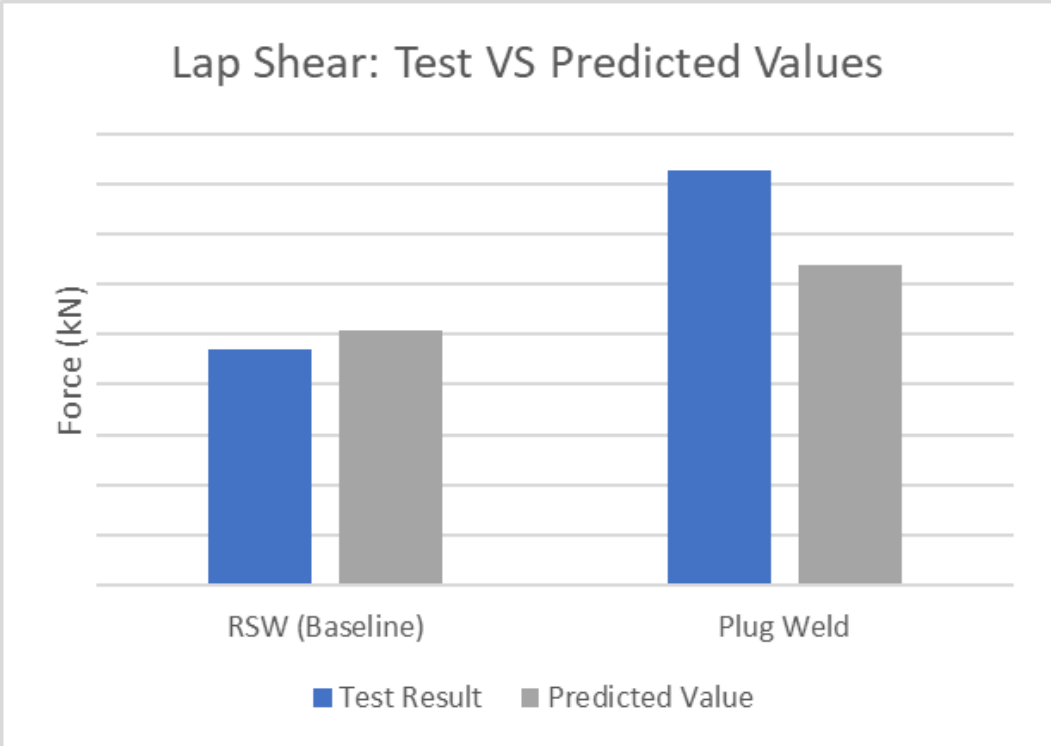
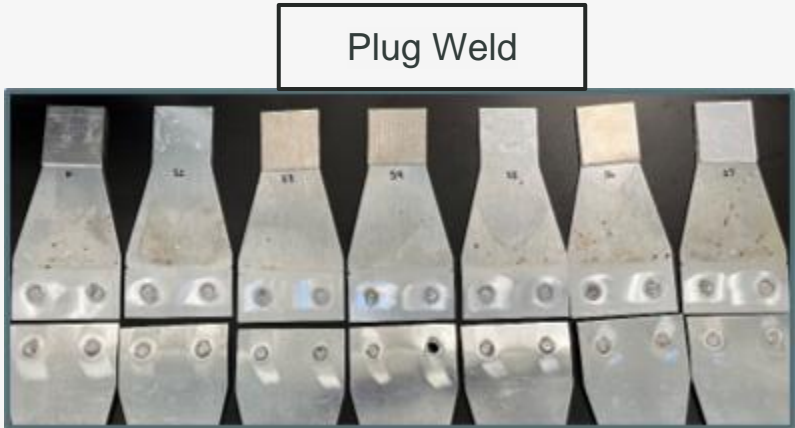

# Collision Repair Development

Front & Rear Frame Rail Procedure

Repair Concept

CAE Validation

**Component Testing**

CAE Correlation

Durability Validation

Prototype Fabrication

Repair Process Validation

Service Part Finalization

Final Design Approval

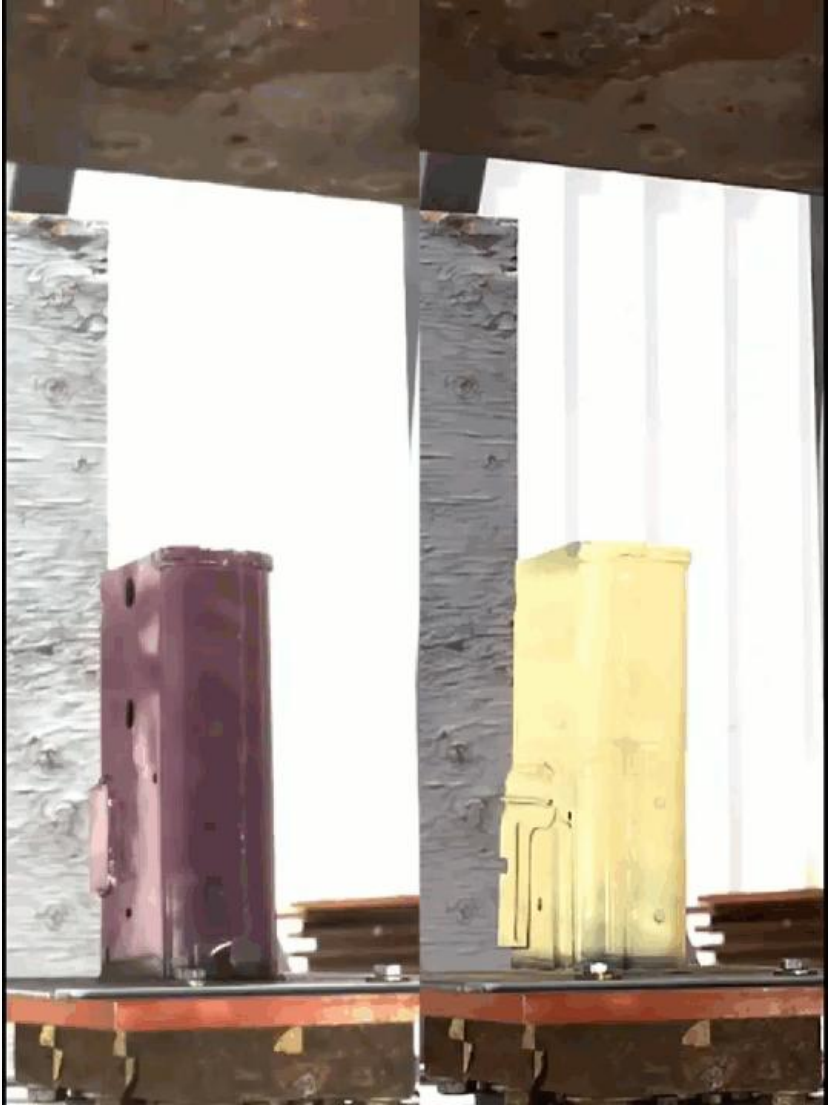
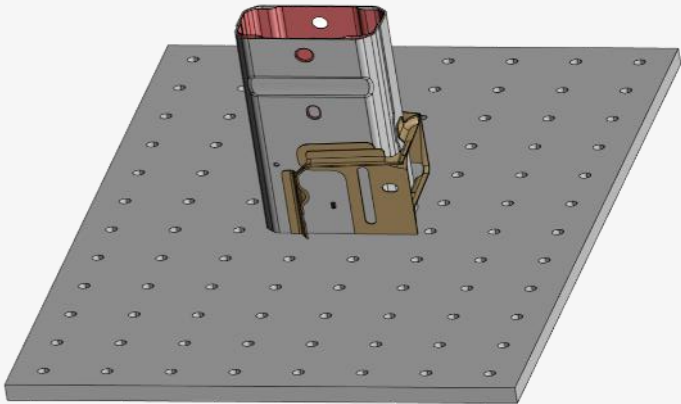

# Collision Repair Development

Front & Rear Frame Rail Procedure

Repair Concept

CAE Validation

**Component Testing**

CAE Correlation

Durability Validation

Prototype Fabrication

Repair Process Validation

Service Part Finalization

Final Design Approval

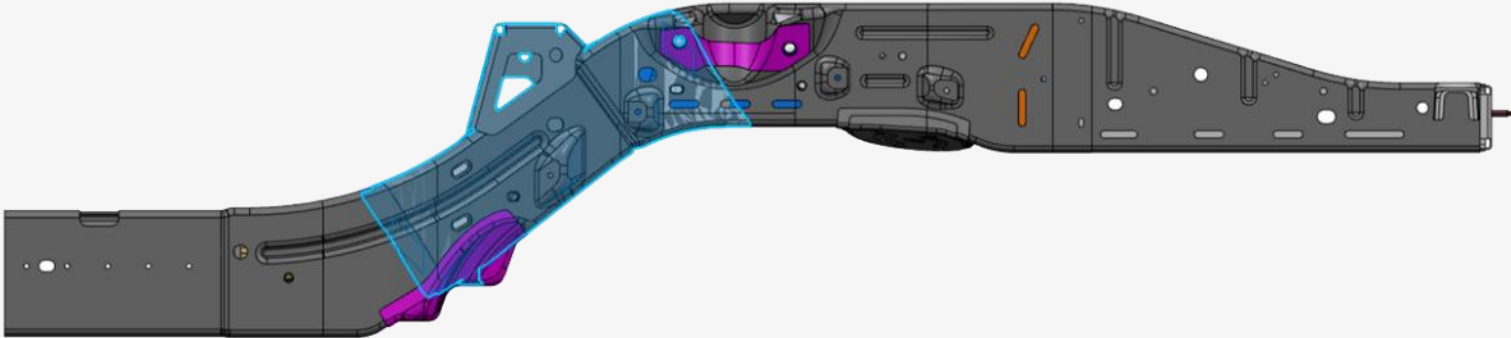

# Collision Repair Development

## Front & Rear Frame Rail Procedure

Repair Concept

CAE Validation

Component Testing

**CAE Correlation**

Durability Validation

Prototype Fabrication

Repair Process Validation

Service Part Finalization

Final Design Approval

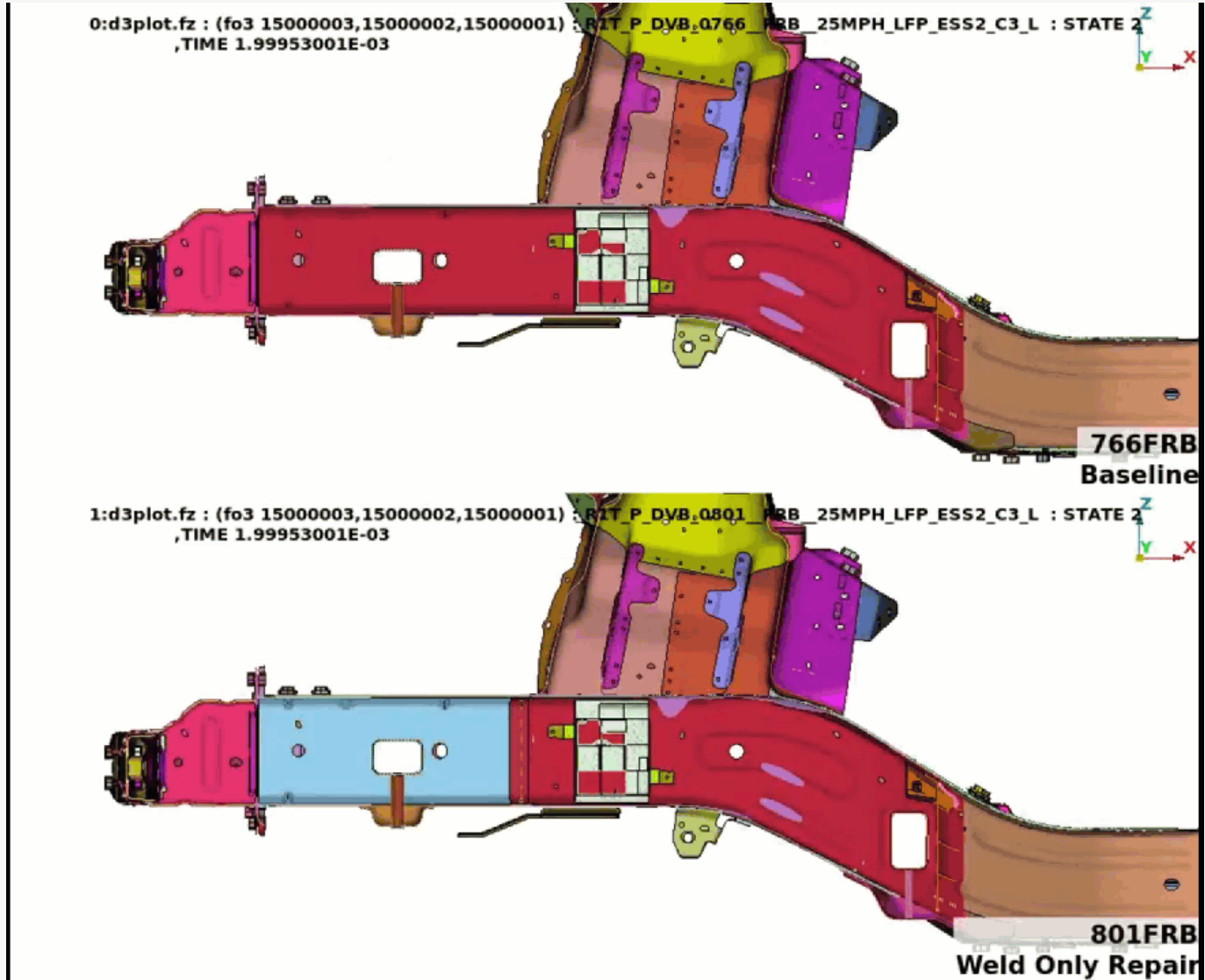

# Collision Repair Development

Front & Rear Frame Rail Procedure

Repair Concept

CAE Validation

Component Testing

**CAE Correlation**

Durability Validation

Prototype Fabrication

Repair Process Validation

Service Part Finalization

Final Design Approval

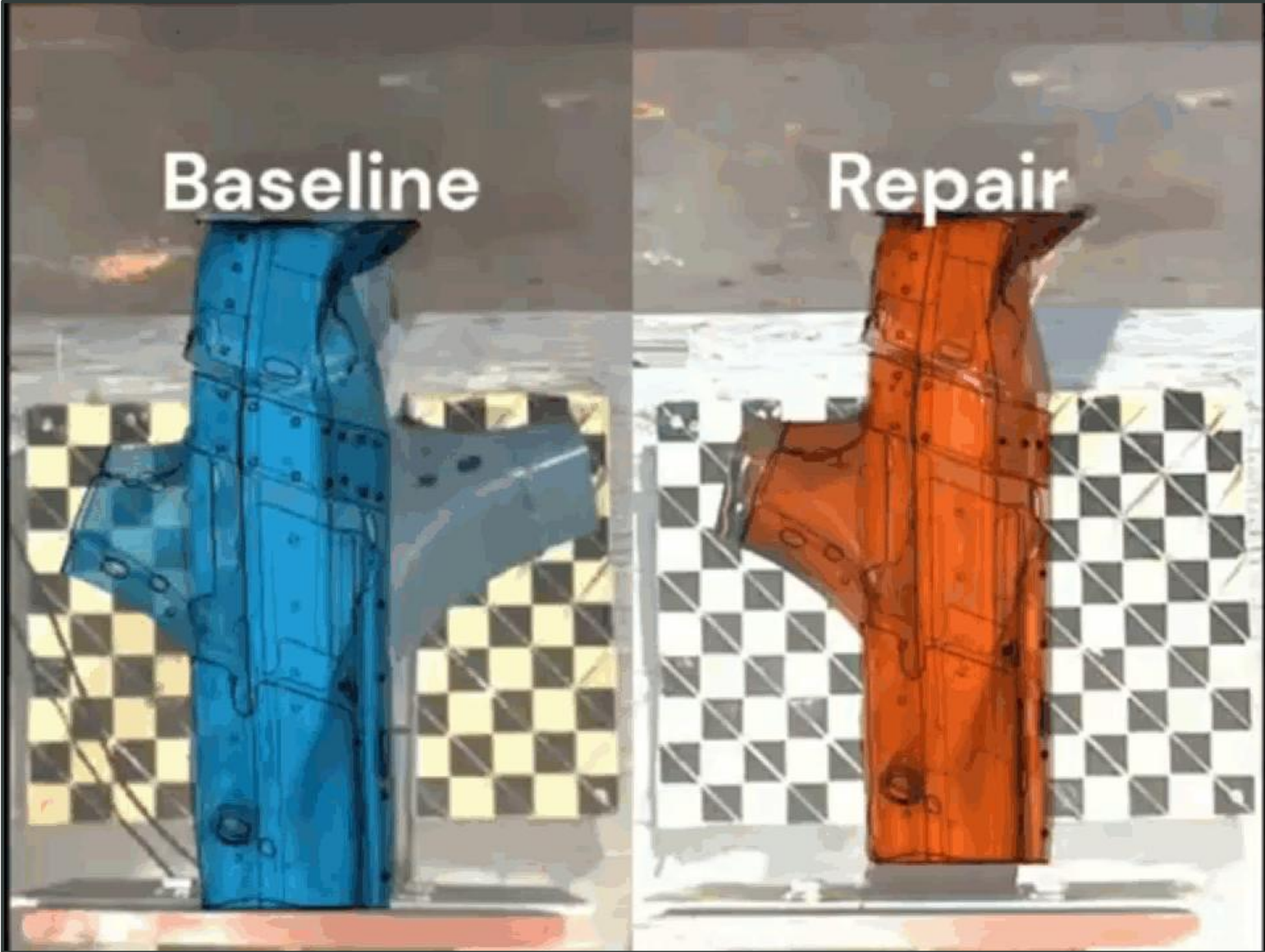

# Collision Repair Development

Front & Rear Frame Rail Procedure

Repair Concept

CAE Validation

Component Testing

CAE Correlation

**Durability Validation**

Prototype Fabrication

Repair Process Validation

Service Part Finalization

Final Design Approval

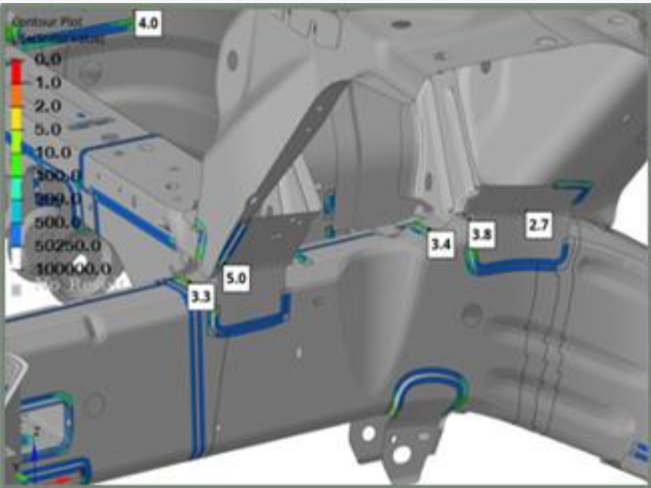
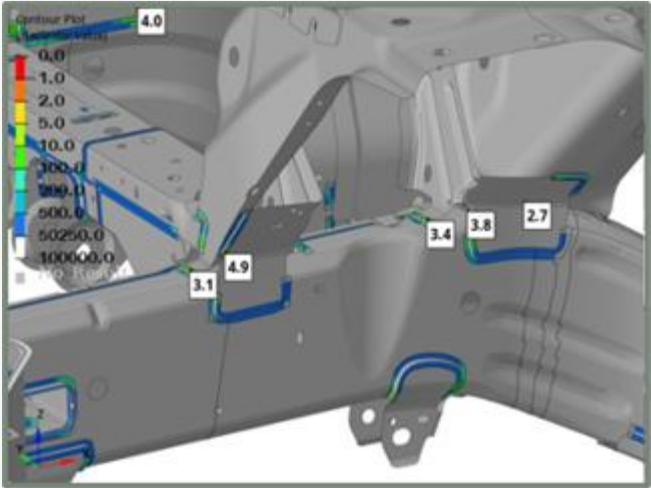

# Collision Repair Development

## Front Frame Rail Procedure

Repair Concept

CAE Validation

Component Testing

CAE Correlation

Durability Validation

**Prototype Fabrication**

Repair Process Validation

Service Part Finalization

Final Design Approval

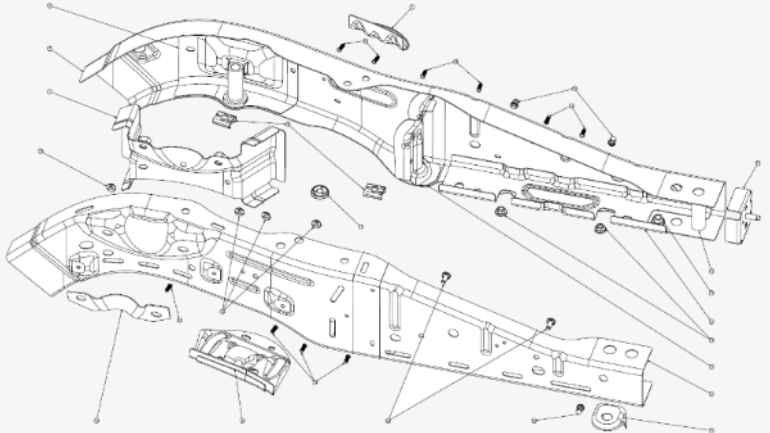
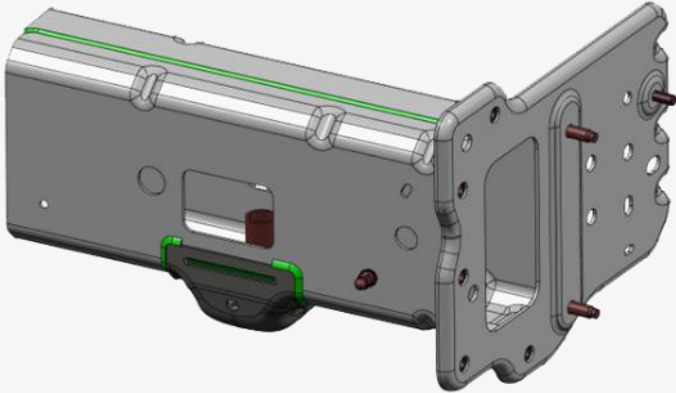

PFD16031-1-1 RAY REC - KIT Rear Service Rail LH	
REV	DESCRIPTION
1	INITIAL RELEASE
2	REVISION
3	REVISION
4	REVISION
5	REVISION
6	REVISION
7	REVISION
8	REVISION
9	REVISION
10	REVISION
11	REVISION
12	REVISION
13	REVISION
14	REVISION
15	REVISION
16	REVISION
17	REVISION
18	REVISION
19	REVISION
20	REVISION
21	REVISION
22	REVISION
23	REVISION
24	REVISION
25	REVISION
26	REVISION
27	REVISION
28	REVISION
29	REVISION
30	REVISION
31	REVISION
32	REVISION
33	REVISION
34	REVISION
35	REVISION
36	REVISION
37	REVISION
38	REVISION
39	REVISION
40	REVISION
41	REVISION
42	REVISION
43	REVISION
44	REVISION
45	REVISION
46	REVISION
47	REVISION
48	REVISION
49	REVISION
50	REVISION
51	REVISION
52	REVISION
53	REVISION
54	REVISION
55	REVISION
56	REVISION
57	REVISION
58	REVISION
59	REVISION
60	REVISION
61	REVISION
62	REVISION
63	REVISION
64	REVISION
65	REVISION
66	REVISION
67	REVISION
68	REVISION
69	REVISION
70	REVISION
71	REVISION
72	REVISION
73	REVISION
74	REVISION
75	REVISION
76	REVISION
77	REVISION
78	REVISION
79	REVISION
80	REVISION
81	REVISION
82	REVISION
83	REVISION
84	REVISION
85	REVISION
86	REVISION
87	REVISION
88	REVISION
89	REVISION
90	REVISION
91	REVISION
92	REVISION
93	REVISION
94	REVISION
95	REVISION
96	REVISION
97	REVISION
98	REVISION
99	REVISION
100	REVISION



# Collision Repair Development

Front & Rear Frame Rail Procedure

Repair Concept

CAE Validation

Component Testing

CAE Correlation

Durability Validation

Prototype Fabrication

**Repair Process Validation**

Service Part Finalization

Final Design Approval



# Collision Repair Development

## Front & Rear Frame Rail Procedure

Repair Concept

CAE Validation

Component Testing

CAE Correlation

Durability Validation

Prototype Fabrication

Repair Process Validation

**Service Part Finalization**

Final Design Approval

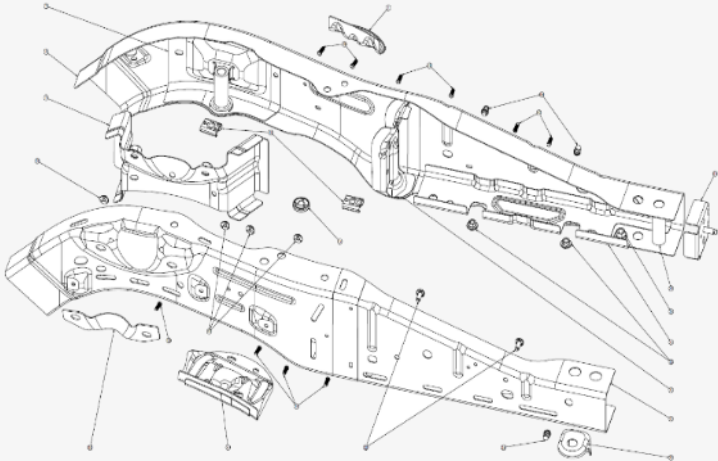
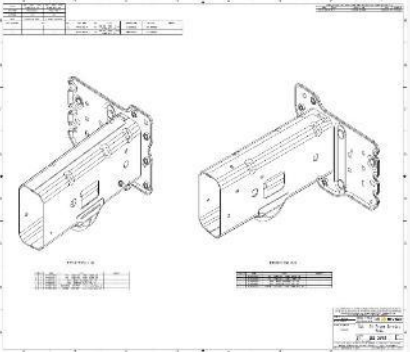
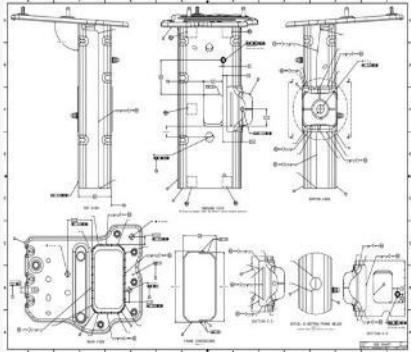

# Collision Repair Development

Front & Rear Frame Rail Procedure

Repair Concept

CAE Validation

Component Testing

CAE Correlation

Durability Validation

Prototype Fabrication

Repair Process Validation

**Service Part Finalization**

Final Design Approval

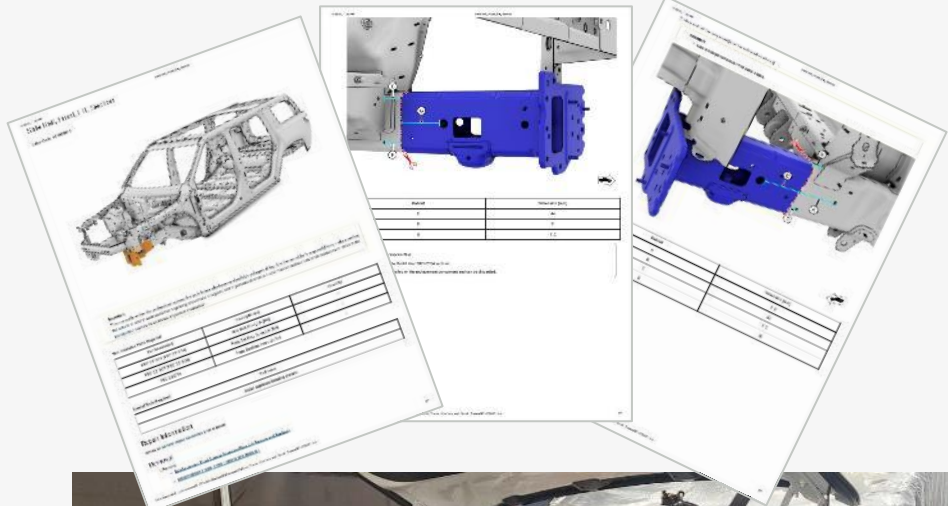

# Collision Repair Development

## Front & Rear Frame Rail Procedure

Repair Concept

CAE Validation

Component Testing

CAE Correlation

Durability Validation

Prototype Fabrication

Repair Process Validation

Service Part Finalization

**Final Design Approval**

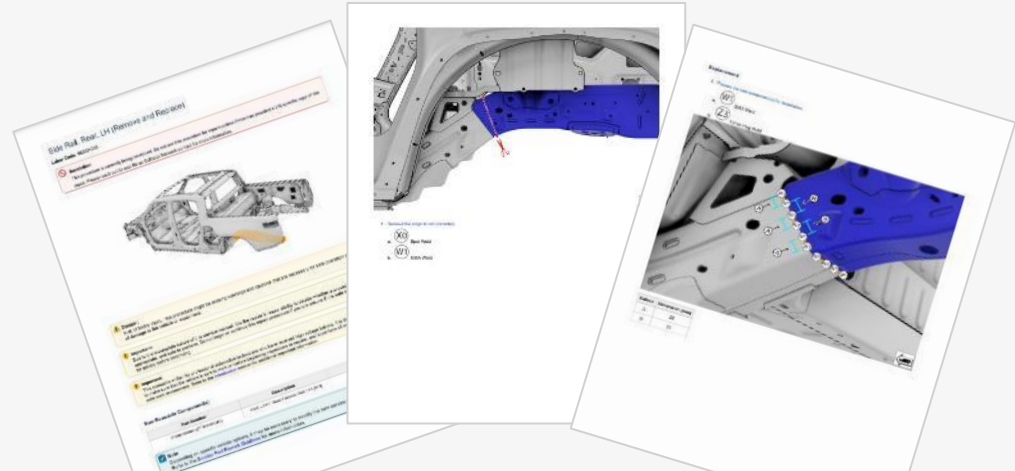

# Thank You

