

# GREAT DESIGNS IN **STEEL**

## **Innovative Steel Cold Plate For Battery Packs: A comprehensive analysis of welding feasibility and corrosion**

Yannis Kheyati – Senior Research Engineer

ArcelorMittal

# Agenda

- Design integration
- Corrosion evaluation
- Joining assessment
- Conclusion

# Cold plate in battery pack today

Aluminum packs with separate aluminum cold plates – Ford, BMW

Aluminum packs with integrated floor and cooling system – VW, Renault, Nissan, Toyota etc.

Steel packs with cooled modules – GM’s Ultium

Future programs – steel packs and with aluminum cold plates and multi-material joining

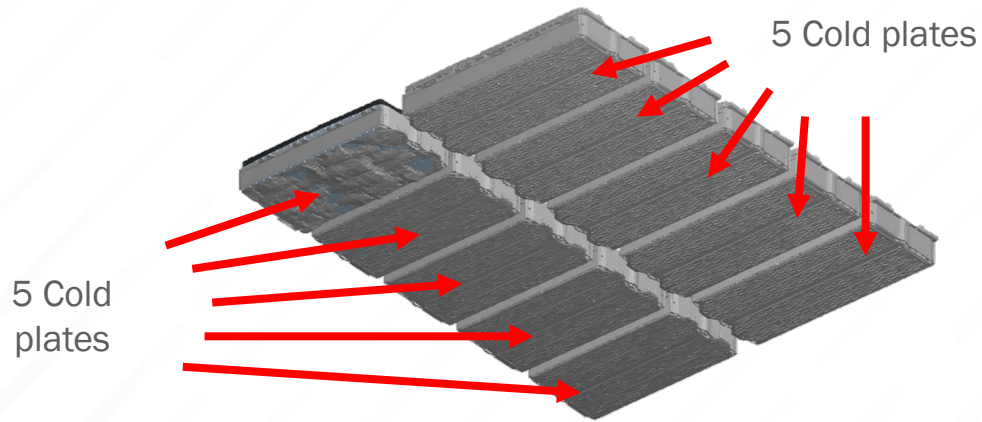

*Cold plate as a separate non-structural part  
Module bottom view – BMW iX 2022 – A2Mac1*

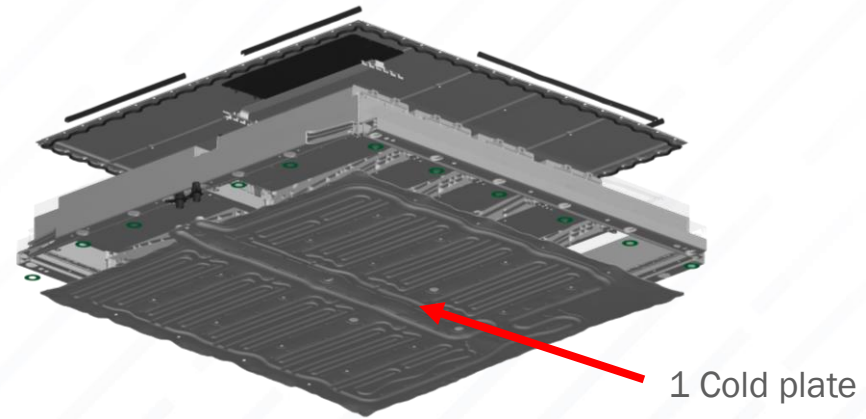

*Cold plate integrated into battery enclosure  
Battery enclosure view – VW ID.3 2020 – A2Mac1*

# Design integration

Steel Solution for cold plate enables steel battery enclosures without multi-material joining challenges

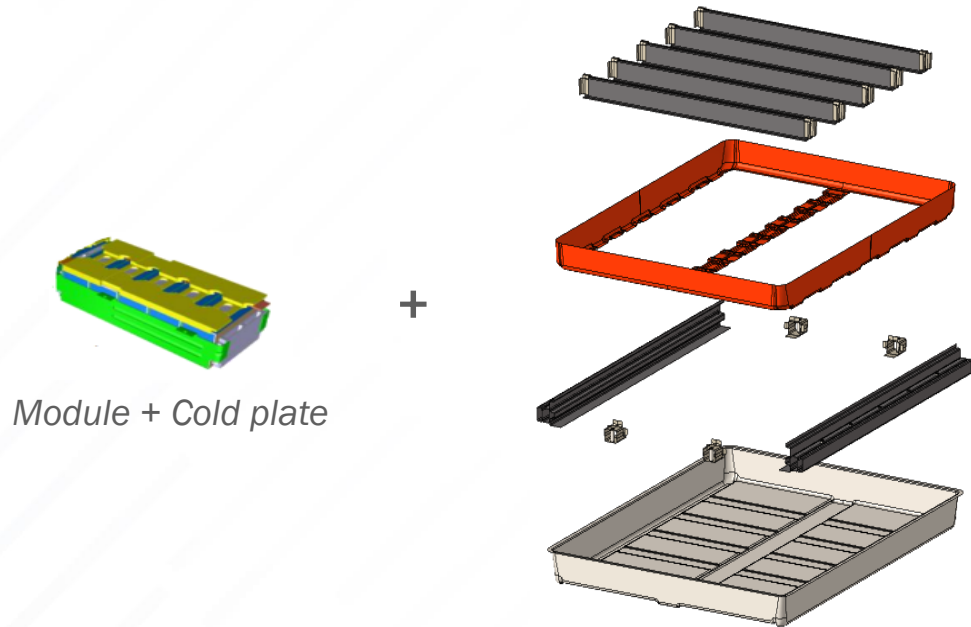

Or

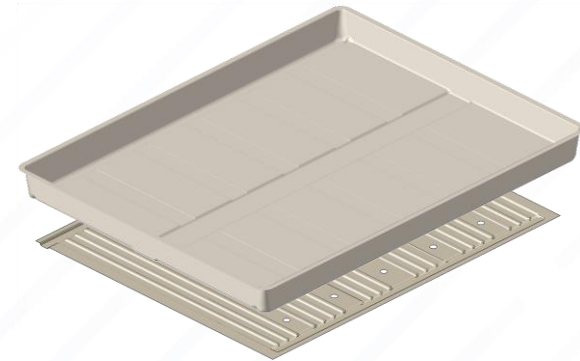

Cold plate as a separate non-structural part or as a part integrated into module

Stamped tray concept – Exploded view

# Agenda

- Design integration
- **Corrosion evaluation**
- Joining assessment
- Conclusion

# Corrosion evaluation: Coolant compatibility

- Corrosion conditions: Test conditions NF R 15-602-7
- Multiple coolants tested
- Tested materials
  - Aluminum as reference (Al 6016)
  - Bare steel
  - Al based coatings: Alusi® (AS), Aluzinc® (AZ)
  - Zn based coatings: HDGI, Galvan (ZA), Zagnelis® Protect
- Damage characterization
  - Visual
  - Mass gain and mass loss
  - Microscopic corrosion profile + GDOES



*Equipment with 3 thermostated reactors*



*Coolant reactor  
(V = 750 ml)*

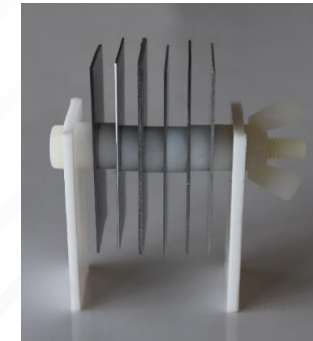

*Sample holder*







# Corrosion evaluation: Summary with different coolants

Substrate	Coating type	Coating	Coolant 1	Coolant 2	Coolant 3
Aluminum (Al 6016)	None	None			
Steel (CR Steel)	None	None			Not tested
	Aluminum-based	Alusi® (AS) (90% Al, 10% Si) for cold-stamping			
		Aluzinc® (AZ) (55% Al, 43.4% Zn, 1.6% Si)			
	Zinc-based	GI (Pure Zn)			Not tested
		Galfan (95% Zn, 5% Al)			
		Zagnelis® Protect (3.7% Al, 3% Mg, Balance Zn)			Not tested

According to corrosion standard requirements, suitable coatings :

- Alusi® (AS) (AS150) → Recommended solution
- Bare steel – Possibility to propose a mono-side electrogalvanized solution (Zn protection of side not in contact with coolant)
- Aluzinc® (AZ)



# Corrosion evaluation: Typical results

Substrate	Aluminum	Steel	Aluminum-based coating		Zinc-based coating		
Coating	None	None	Alusi® (AS) for cold-stamping (90% Al, 10% Si)	Aluzinc® (AZ) (55% Al, 43.4% Zn, 1.6% Si)	GI (Pure Zinc)	Galfan (95% Zn, 5% Al)	Zagnelis® Protect (3.7% Al, 3% Mg, Balance Zn)
Coolant T = 100°C Time = 14 days							
Mass gain [mg/sample]*	0.5	0.2	1.8	1.2	35	51	56
Mass loss [mg/sample]*	1.2	2.6	0	1.1	1.1	0.3	17

\*Maximum value for validation = 2.5mg/sample

Zinc-based coatings not OK because of mass gain/precipitate formation.  
Very good results on Alusi® (AS), Aluzinc® (AZ), and bare steel.

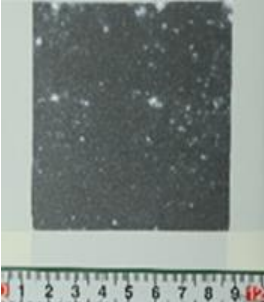
# Corrosion evaluation: Perforating corrosion on full panels

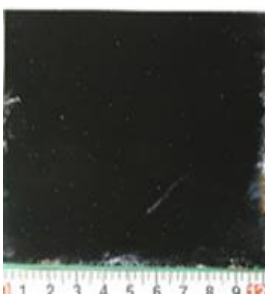
Cyclic Corrosion Test	Position of samples	Target	Coating Solution			
			Without e-coat			With e-coat
			Zagnelis® Protect 310 (25µm) + e-passivation	Alusi® (AS) 150 (25µm) for cold-stamping	GI (Z275 - 20µm) + Coil-coating paint (25µm)	GI (Z140 - 10µm) + e-coat (25µm) - Reference
VDA-New 12 cycles	Horizontal	Simulate corrosion with low deformations, and high water retention	 <p>No red rust</p>	 <p>No red rust</p>	 <p>No red rust</p>	 <p>No red rust</p>





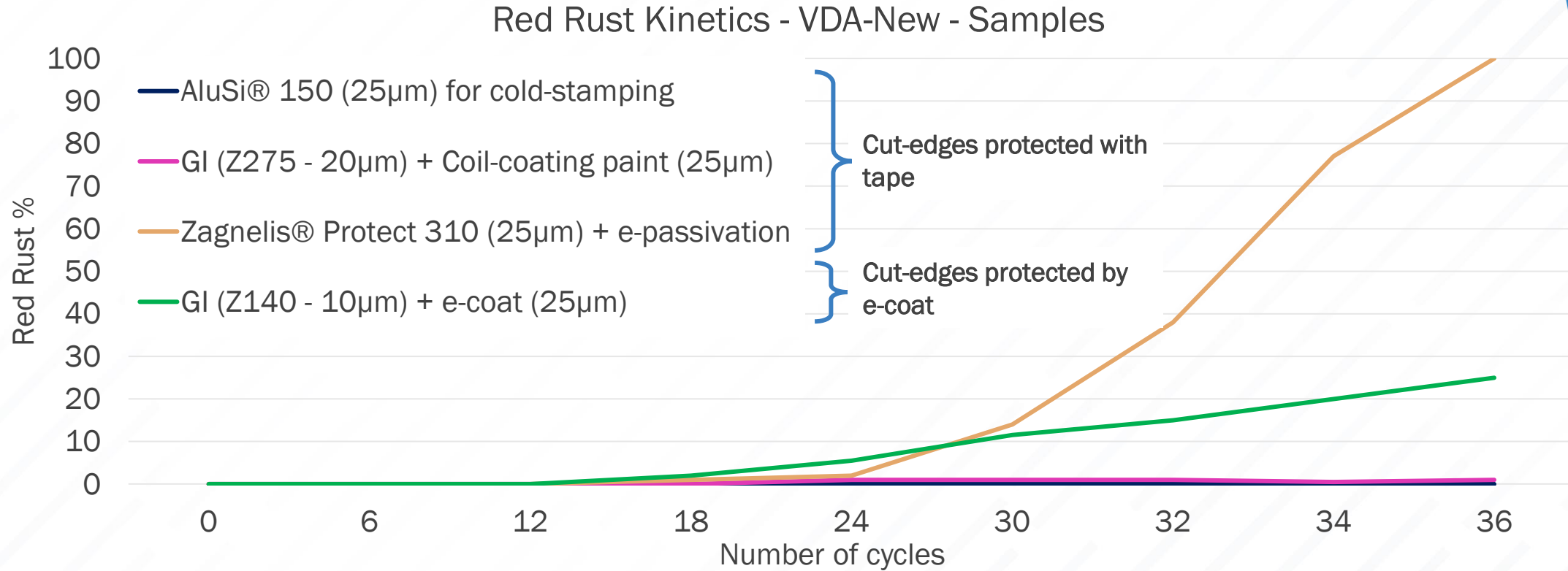

Pre-coated steel solutions (without e-coat) can offer similar anti-corrosion performance (no red rust) to post-coated steel solutions (with e-coat), at a reduced cost.

# Corrosion evaluation: Perforating corrosion on full panels

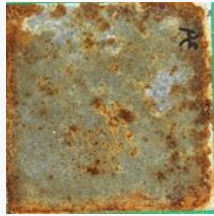

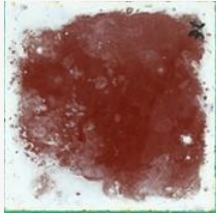
Really high perforating corrosion resistance with all pre-coated steel solutions  
(target = 24 cycles with less than 5% of red rust)

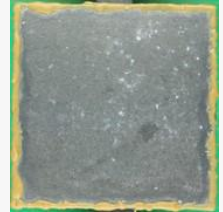
# Corrosion evaluation: Cut-Edges re-protection strategies

Cyclic Corrosion Test	Position of samples	Steel thickness [mm]	Cut-edge protection solution	Coating Solution		
				Alusi® (AS) 150 (25µm) for cold-stamping	Zagnelis® Protect 310 (25µm) + e-passivation	GI (Z275 – 20µm) + Coil-coating paint (25µm)
VDA-New 12 cycles	Horizontal	0.7	None Reference			
			Wax Pfinder UBS 694			

Same results at 41 cycles

Cut-edges corrosion protection of pre-coated Steel Solutions can be improved through secondary protections. Possibility to protect welded areas with those same products.

# Agenda

- Design integration
- Corrosion evaluation
- **Joining assessment**
- Conclusion

# Joining assessment

- Critical requirement – Watertight joint in the perimeter
- Zero porosity – pathway for coating vapors, if any, to escape
- Interior joints – can be discrete if cross flow between channels is controlled

	Laser	Roller Seam	Wire seam
Joining speed	+++	++	++
Distortion risk due to heat input	++	+	+
Complex joining paths	+++	+	+
Fixturing and Process	+	+++	+++

Laser welding is a good compromise based on technical constrains

# Joining assessment: Laser welding trials

- Laser welding trials were performed to study the impact of Alusi® (AS) for cold-stamping on weld quality
- Objective: Obtain strong and continuous weld to ensure watertightness

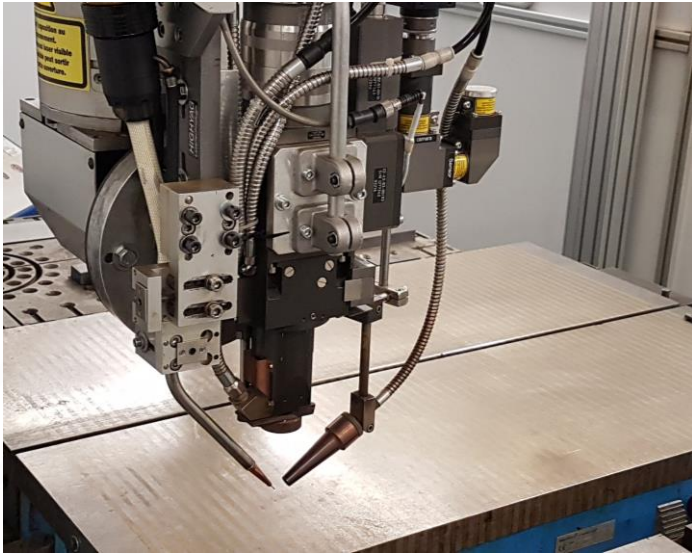

Laser welding setup at ArcelorMittal  
Montataire R&D

- Laser source: 5kW disk laser from Trumpf
- Coatings assessed – Alusi® (AS) and Aluzinc® (AZ)
- Single spot 0,6mm
- Investigation from 6 to 12m/min:
  - At 10m/min, the root size becomes narrow
  - Higher speed, weld would not be fully penetrated
- Speed selected: 9m/min



Cooling system made of  
CR Steel – 0.6mm

Laser welding is a good compromise based on technical constrains

# Joining assessment: Coating results

- Aluzinc® (AZ) Coating:
  - Different approach tested: defocusing, gap between sheets, various speed, etc.

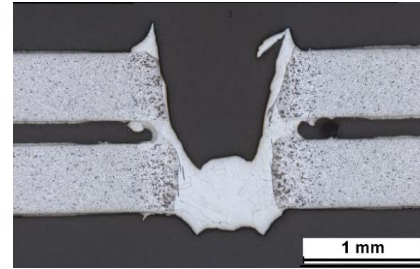

CR grade with Aluzinc® (AZ)  
Cross section



Aluzinc® (AZ) coating  
vaporisation

- Alusi® (AS) Coating:
  - Coating is continuous until the molten zone
  - Very large grains in the weld zone

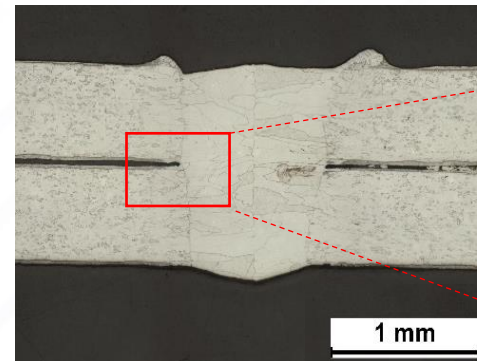

CR grade with Alusi® (AS) – Cross section

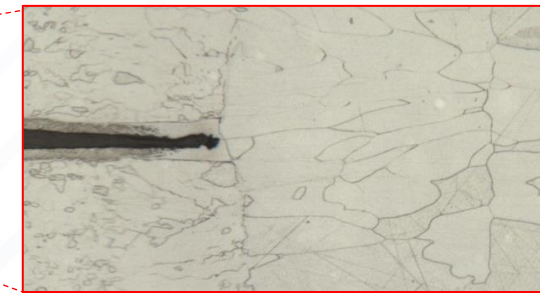

Alusi® (AS) coating with CR grades are compatible with laser welding process

# Joining assessment: Weld strength

- Coatings evaluated:
  - Alusi® (AS) 120 for cold-stamping
  - Alusi® (AS) 150 for cold-stamping
  - Bare steel as reference
- Coupons test:
  - Tensile shear test (TSS)
  - Peel test
  - Weld length 45mm (as defined in SEP1220-3)

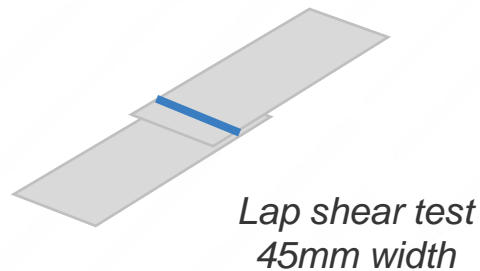
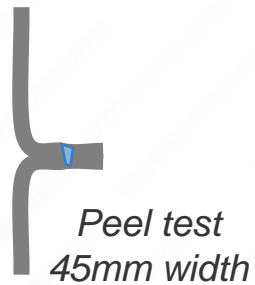

Alusi® (AS) 150 for cold-stamping peel test



Bare steel peel test

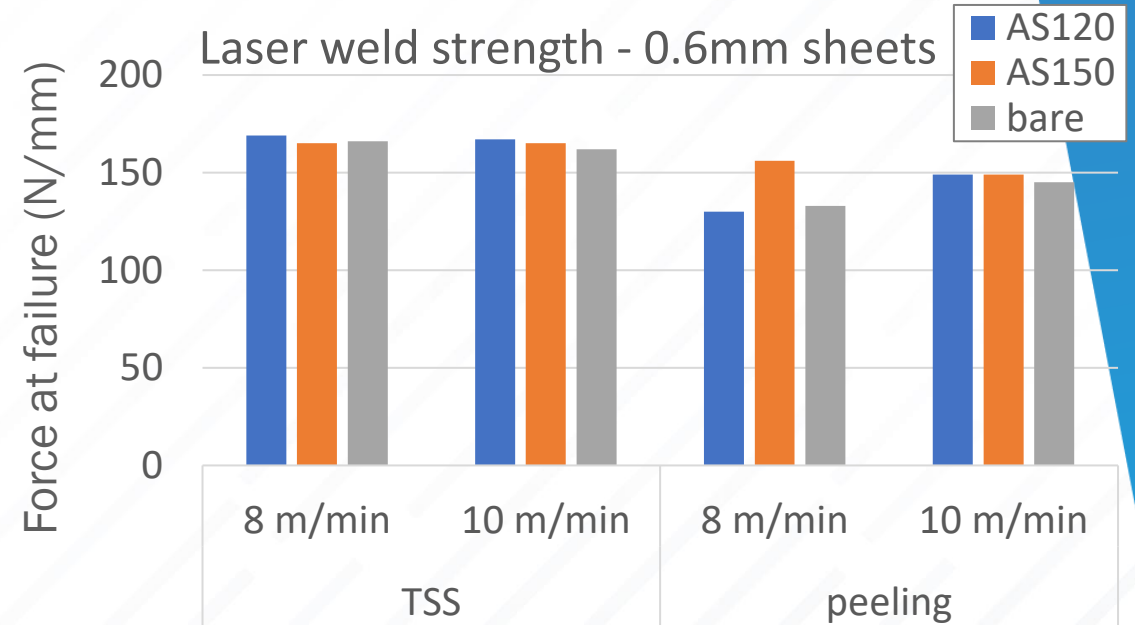

No influence of the coating on the weld strength.

Failure occurs in the HAZ due to local stress concentration. Chemical composition does not affect the weld strength on molten zone.

# Joining assessment: Alusi® (AS) for cold-stamping coating solution

- Coating composition: 90% Al / 10% Si
- Main characteristics:
  - Outstanding corrosion protection (cut-edges reprotection needed)
  - Outstanding heat and high-temperature oxidation resistance
  - Excellent thermal insulation properties due to its high level of reflectivity
  - Excellent chemical resistance
  - Coating thickness up to 33 µm/side (AS200)



*Scanning electron micrograph of Alusi® (AS) for cold-stamping cross-cut*



*Fuel tank shell made with Alusi® (AS)*



*Catalytic converter heat shield made with Alusi® (AS)*

**Outstanding corrosion protection (cut-edges reprotection needed) – Excellent chemical resistance**  
**Recommended for high temperature applications**

# Joining assessment: Demonstrator

- Leak test with laser welding on demonstrator level “S – Shape”
- Coatings evaluated:
  - Alusi® (AS) 150 for cold-stamping
- Industrialization configuration for a demonstrator test level “S – Shape”:
  - 9m/min speed
  - Trumpf Trudisk 8000
  - PFO33 Focus 450

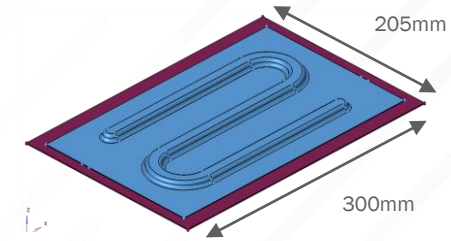

*“S” shape stamped for leak test*



*Physical part - “S – shape” laser welded*

Work in progress for pressure test to assess welds leak performances

# Agenda

- Design integration
- Corrosion evaluation
- Joining assessment
- **Conclusion**

## Conclusion

- **Functional:** Based on simulations, and co-engineering projects with OEMs & Start-ups, steel is a good candidate for cold plate application
- Example of steel cold plate application on co-engineering project with Forsee Power – 0.7mm thin cold plate – Laser welded

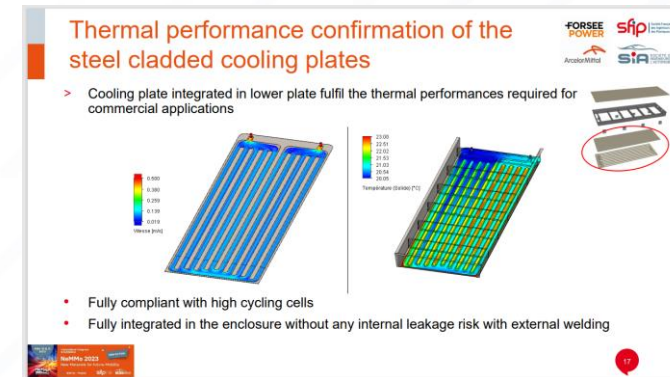
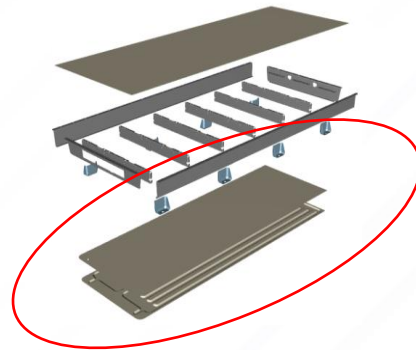

- **Welding:** Alusi® (AS) coating for cold-stamping and bare steel via laser welding was tested and validated on thin plates (0.6mm)
- **Corrosion:** Based on laboratory trials, both Alusi® (AS) for cold-stamping and bare steel are compatible with glycol-based coolants. Re-protection solutions validated on several coatings.

## Future work:

- Work in progress : Pressure testing on demonstrator
- System level validation with prototypes – seeking collaboration
- Continue industrialization and improve process robustness for joining
  - Validate concept with prototype parts levels for process optimization at high volume and limited distortion

## For more information

Yannis Kheyati

ArcelorMittal

yannis.kheyati@arcelormittal.com

Ram Iyer

ArcelorMittal

ram.iyer@arcelormittal.com

# Thank you