

# GREAT DESIGNS IN **STEEL**

## **Steel-Intensive Battery Enclosure Structure (SIBES)**

Tom Wormald  
ArcelorMittal



Yu-Wei Wang, Ph.D.  
Cleveland-Cliffs, Inc.



# Agenda

- Background
- Baseline Aluminum and SIBES CAD
- SIBES Grades and Gages
- Performance Load Cases
- Mass and Performance Score Card
- Conclusion

# Background

## Pre-competitive Project Objectives

- Exploit steel's strength, ductility, and cost benefits to develop a sustainable and cost-effective design concept for a battery enclosure structure that is mass competitive with a given baseline aluminum one with equal, or better, performance.
- Demonstrate steel's value proposition to automakers and ensure that steel remains the material of choice for future architectures planned for 2030 and beyond.

# SIBES Design Approach

- Select a highly efficient aluminum extrusion-intensive battery enclosure as the baseline comparator
- Honor the internal packaging of the battery pack to the best extent possible
- Honor all the attachment locations to the vehicle underbody
- Carry over the aluminum cooling plate
- Convert both the SMC top cover and the SMC bottom panel to steel
- Meet all performance targets as defined by the aluminum baseline
- Work collaboratively with e-Savant to develop a steel solution with the expectation that some reintegration with the underbody structure will be necessary, i.e., it does not need to be a plug-n-play
- Propose a credible, manufacturable concept that can serve as a blueprint for production execution with the appropriate rebalancing with the body-in-white

# Background

## SIBES Design Approach

- The stiffness and strength of the aluminum production enclosure are derived from:
  - Extensive use of multi-cell, thick-walled extrusions
  - MIG welding as the main joining method
- The steel-intensive concept design derived its good structural performance from:
  - Section geometry and gage optimization for good stiffness
  - Steel grade strength and ductility to enable good energy absorption and prevent intrusion
  - Continuous joining technologies such as MIG and Laser welding as well as weld-bonding
  - Bonding the aluminum cooling plate to the crossmembers and the perimeter of the structure

# **BASELINE ALUMINUM & SIBES CAD**

# Aluminum Extrusion-intensive Baseline



# Aluminum Baseline CAD

Total weight = 91.3 kg

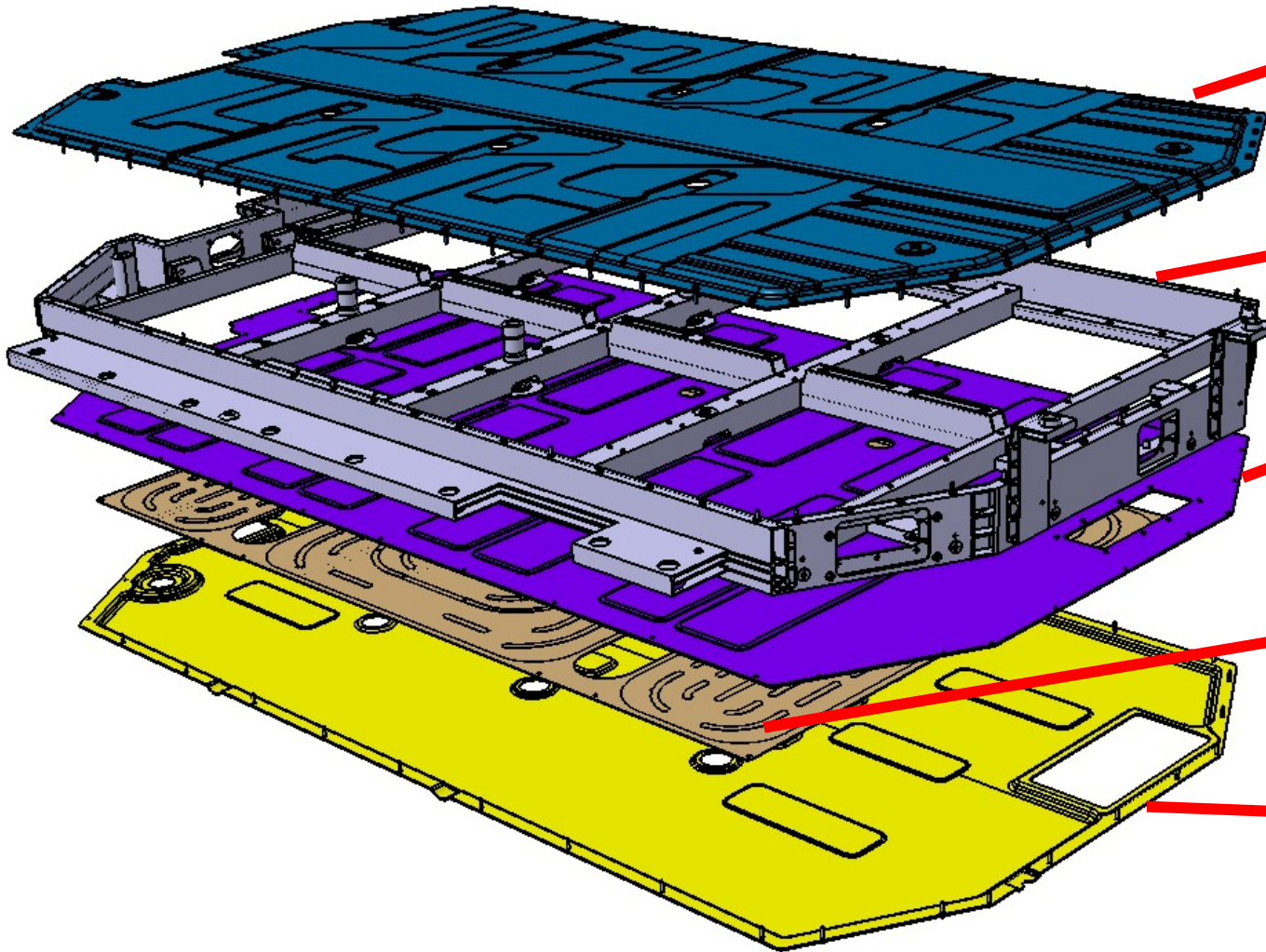

SMC Upper Cover  
Mass= 12.1 kg

Aluminum Housing Structure  
Mass = 36.2 kg

Aluminum Cooling Plate Upper  
Mass= 14.9 kg

Aluminum Cooling Plate Lower  
Mass= 17.5 kg

SMC Lower Plate  
Mass=10.6 kg

# Steel Intensive Concept CAD

Total weight = 95.31 kg | +4.4% over AI baseline

Steel Upper & Lower panels ~ 0.5 kg heavier than baseline SMC panels

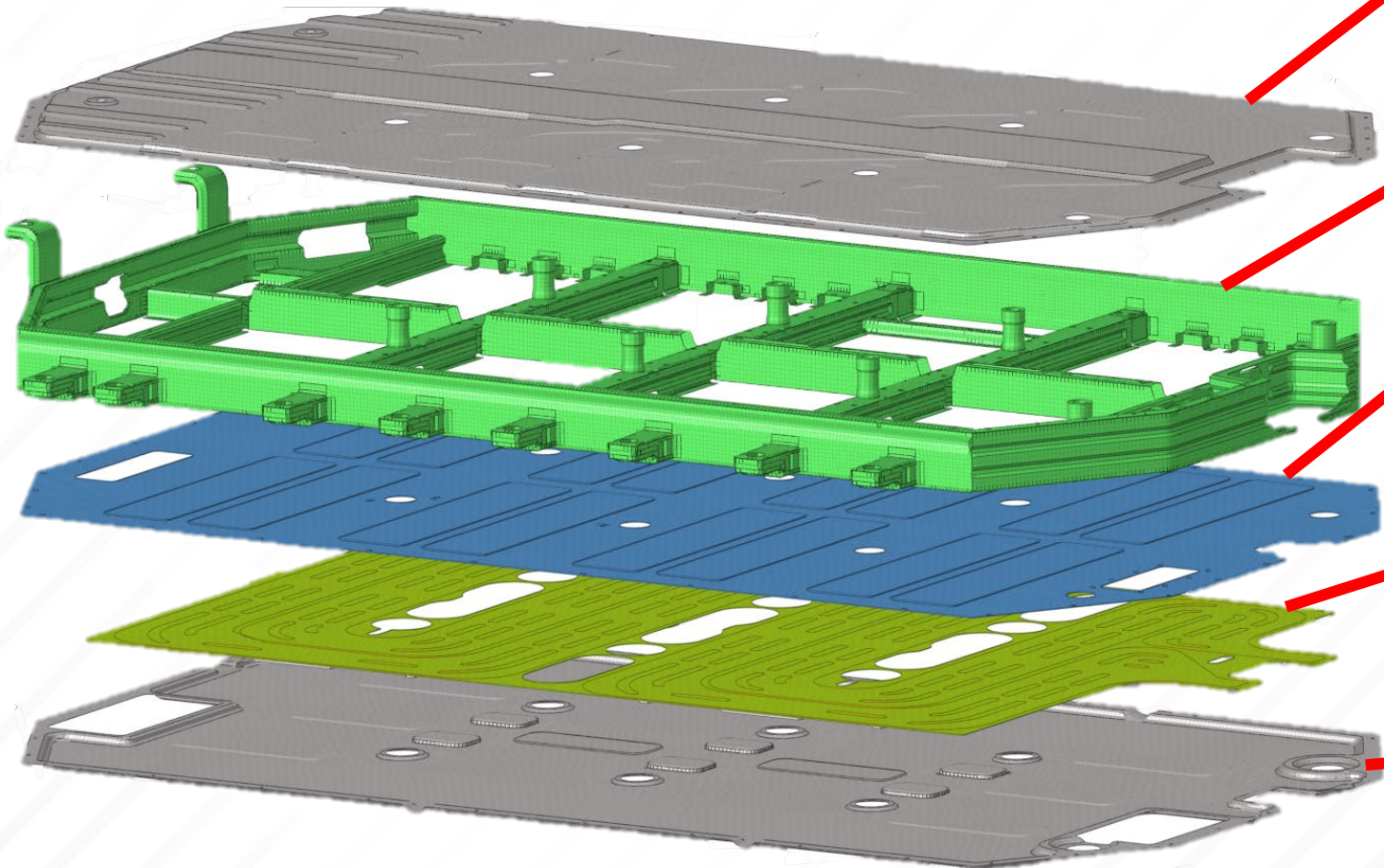

Steel Upper Cover  
Mass= 11.78 kg

Steel Housing Structure  
Mass = 39.72 kg

Aluminum Cooling Plate Upper  
Mass= 14.9 kg

Aluminum Cooling Plate Lower  
Mass= 17.5 kg

Steel Lower Plate  
Mass=11.41 kg

# SIBES Finite Element Model

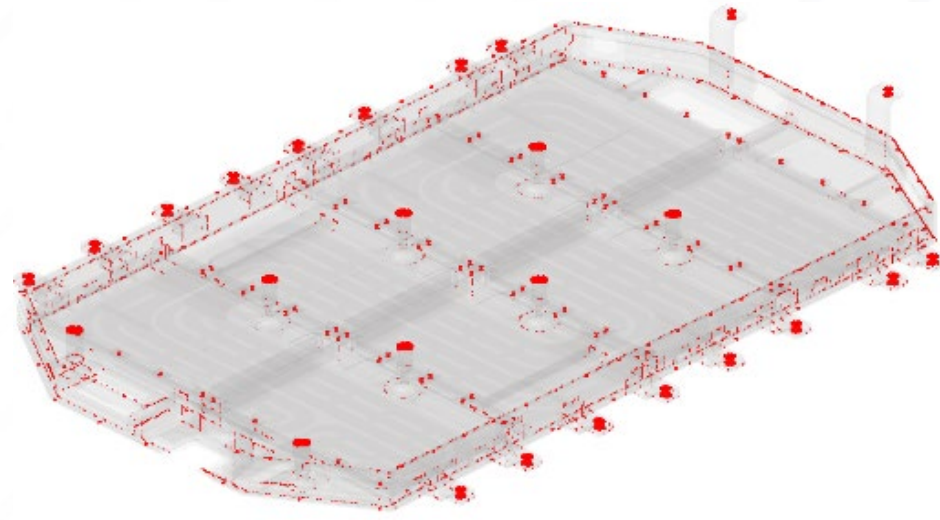
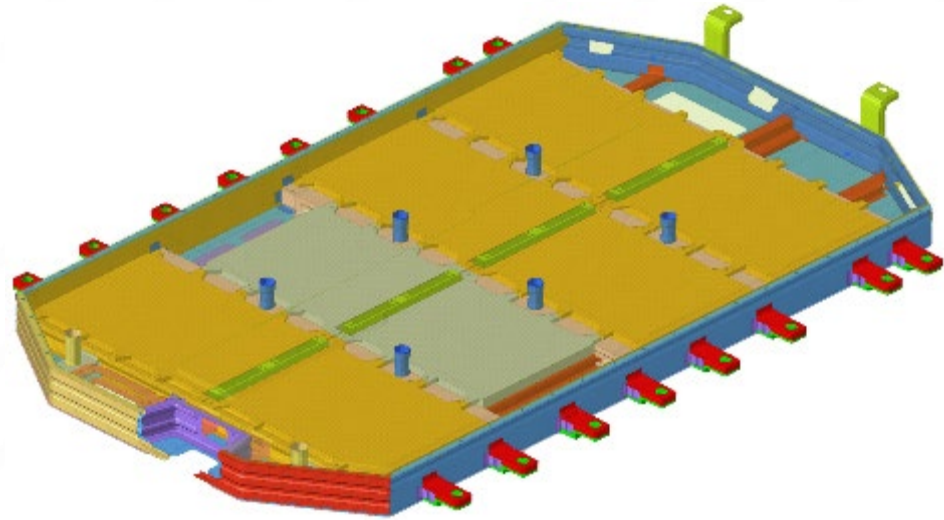

Elements: 389454

Element size: 7mm

Rigid connection and Tied contact representing MIG-welding and Adhesive bonding

# SIBES Highlights

- The FEA model used to evaluate the steel concept performance is based on the optimization of the torsion and bending stiffness and the modal assessments.
- The final steel design concept assumed steel top and bottom panels as a replacement for the baseline SMC panels.
- The side brackets were designed and optimized for side pole impact.
- The side sill sections were also optimized for the side pole event (flanging and internal bulkheads).
- All connections were modelled as seam welds, MIG-welds, or adhesives.

Unlike the AI baseline, the Steel concept leverages strength and ductility to manage impact energy

# **SIBES GRADES AND GAGES**

# Front

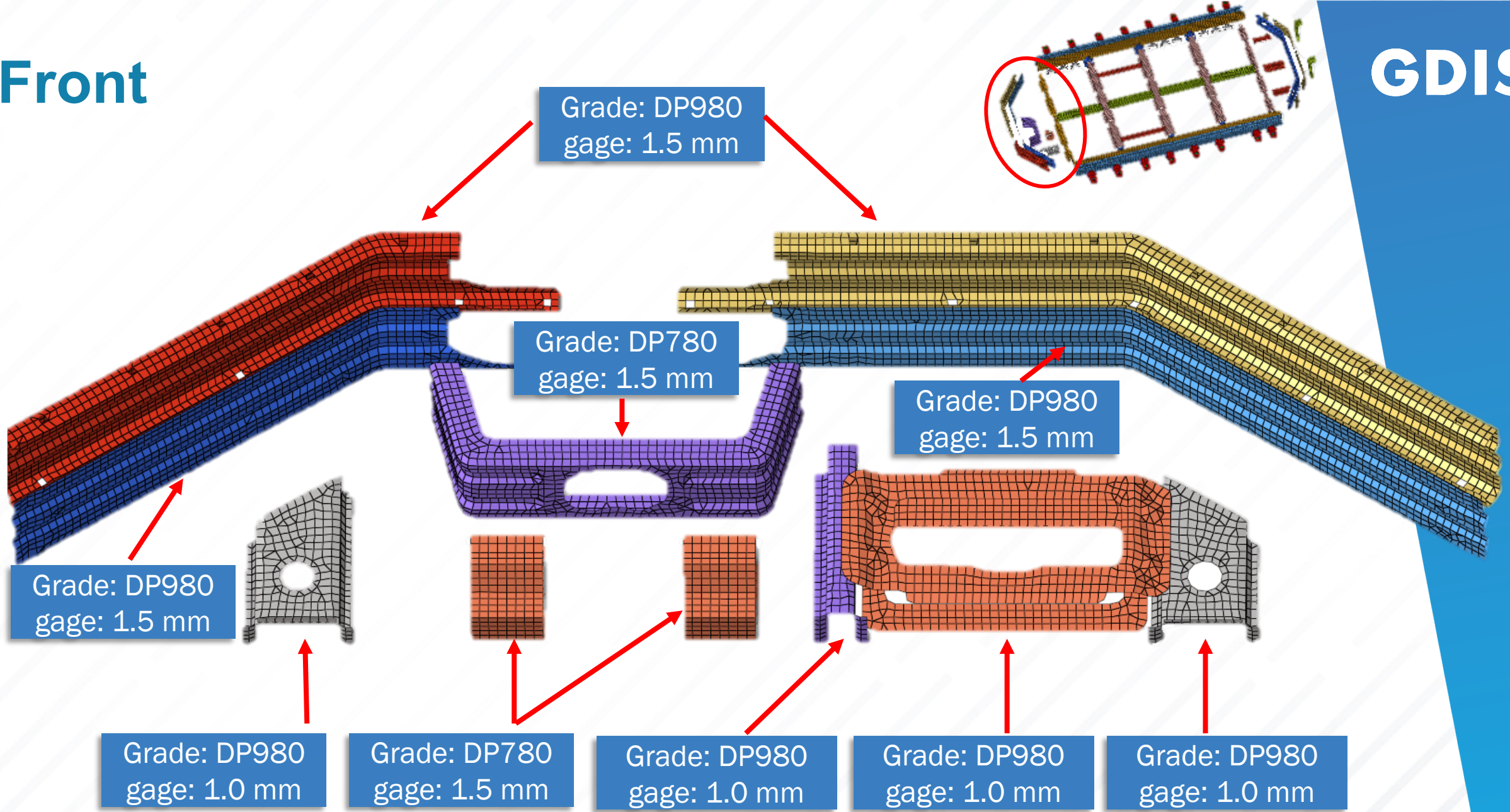

# Rear

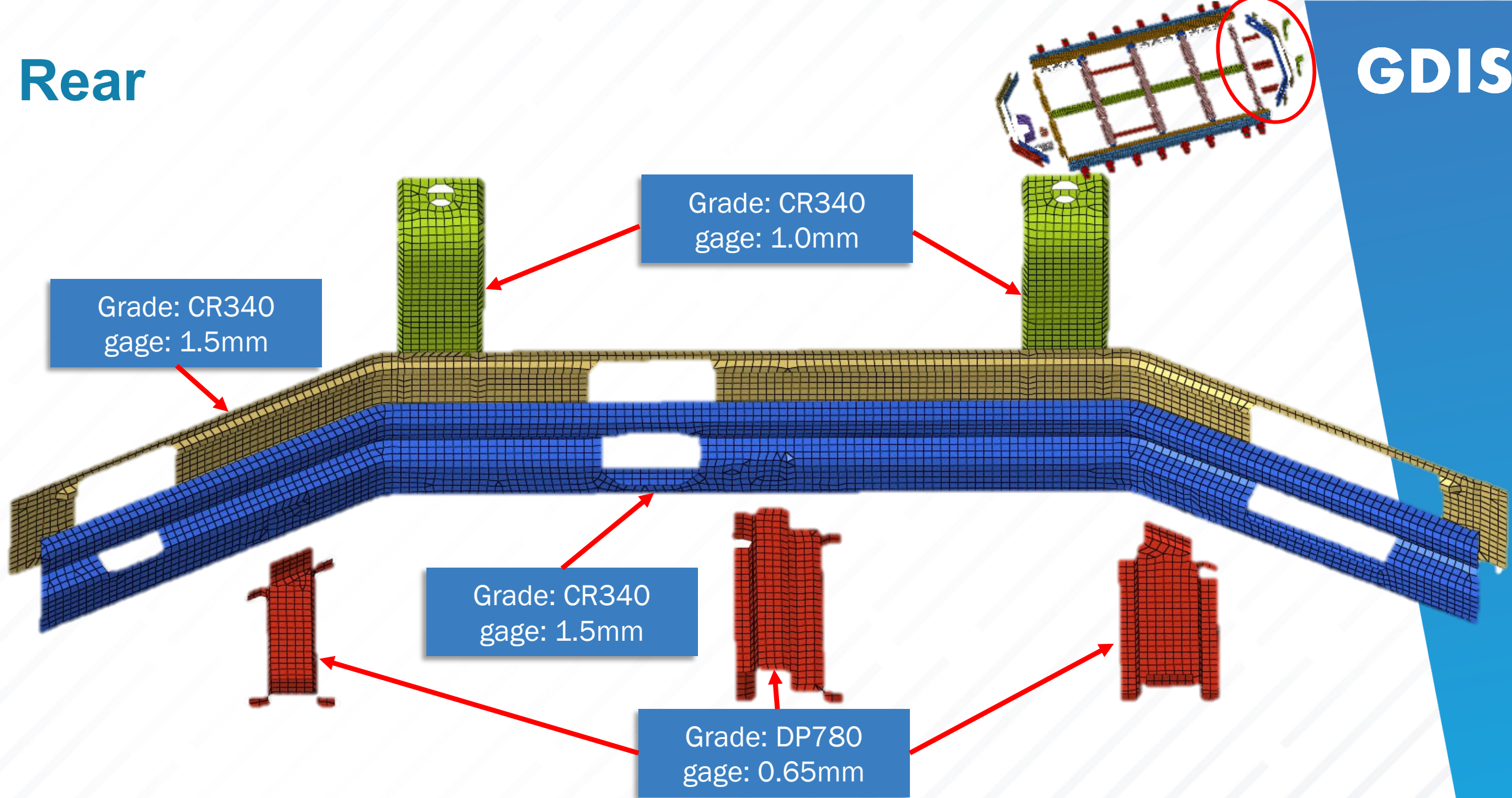

# Center

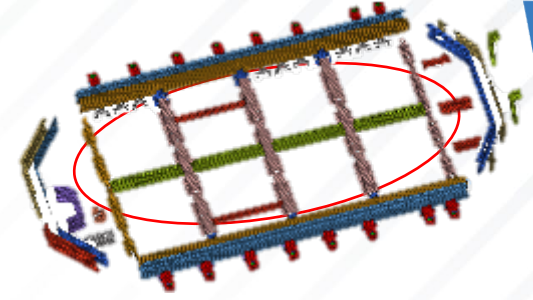

Grade: DP780  
gage: 0.65mm

Grade: DP1180  
gage: 0.8mm

Grade: DP980  
gage: 0.65mm

Grade: MS1500  
gage: 1.0mm

Grade: MS1500  
gage: 1.5mm

Grade: DP980  
gage: 0.65mm

Grade: CR340  
gage: 0.7mm

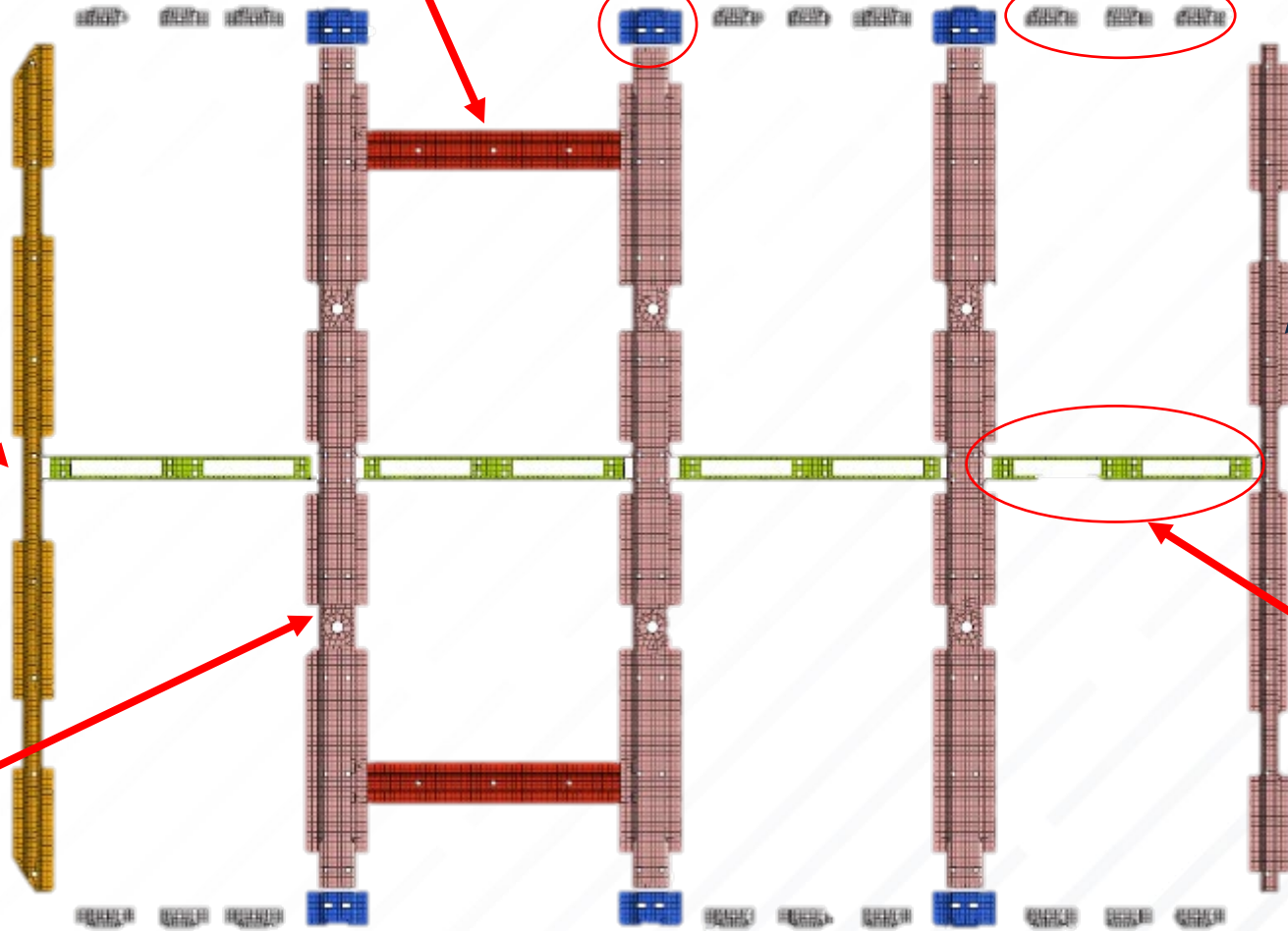

# Side Brackets and Sill

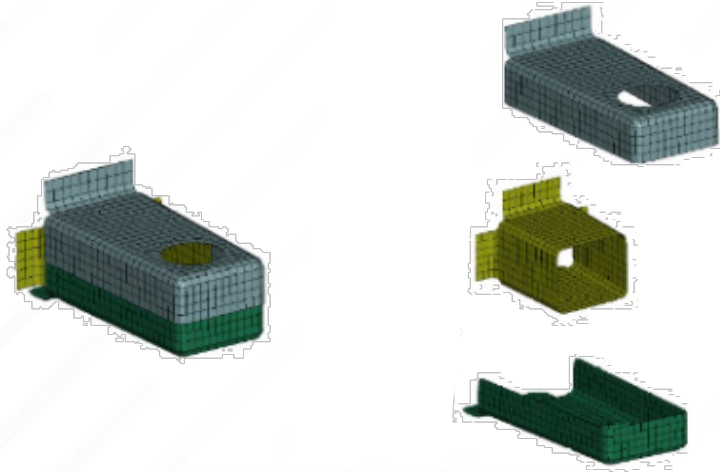
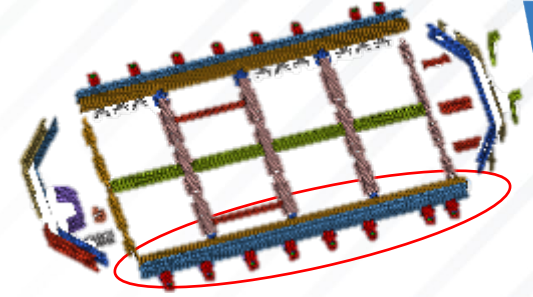

Grade: DP980  
gage: 0.7mm

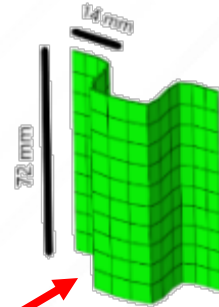
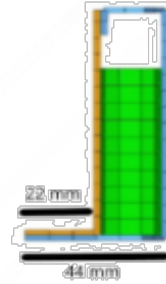

Grade: DP980  
gage: 0.8mm

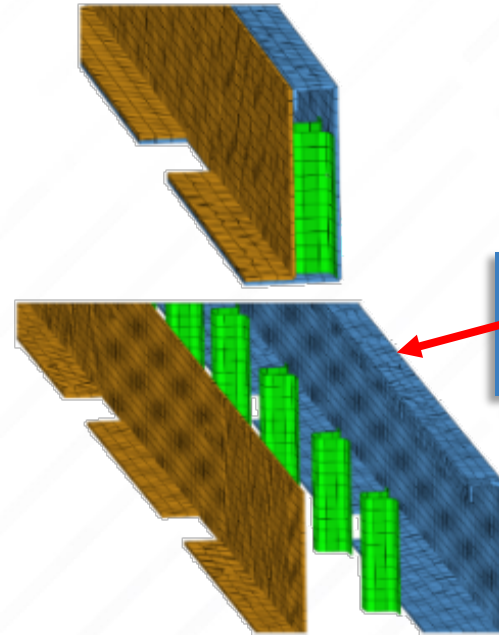

Grade: MS1500  
gage: 2.25mm

Grade: MS1500  
gage: 2.25mm

# Top Cover and Bottom Panel

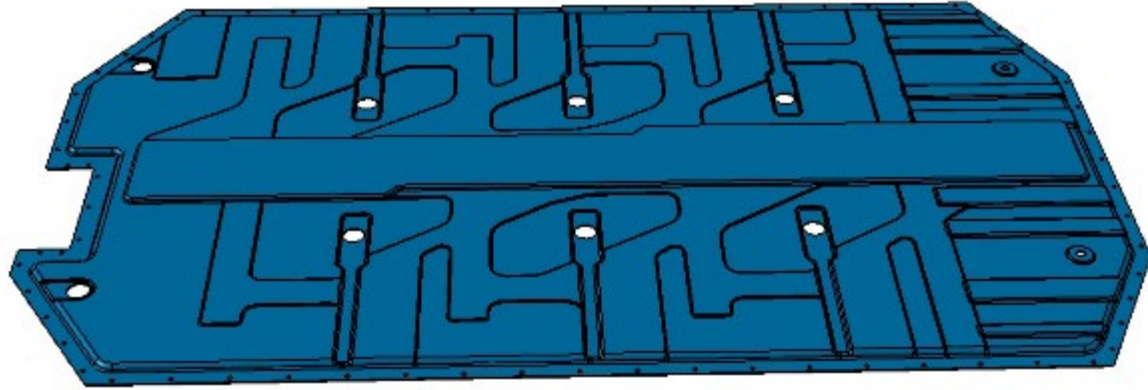

Top Cover: 0.6 mm  
CR4

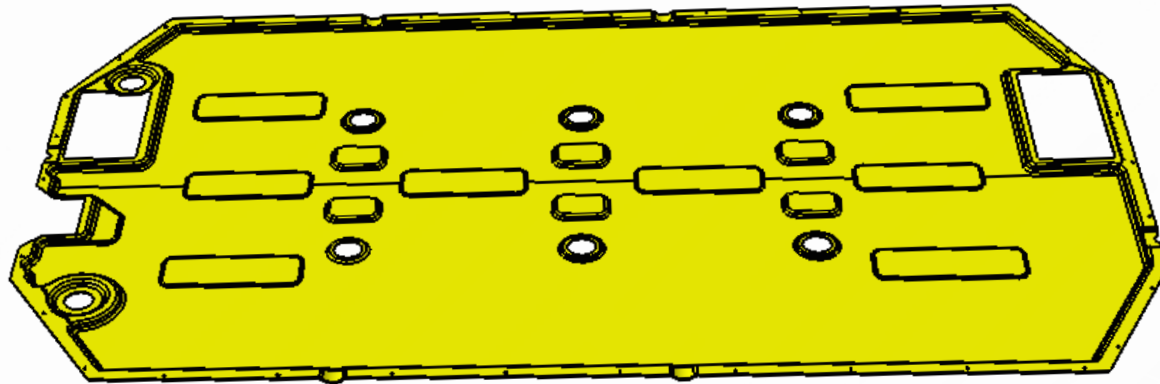

Bottom Panel: 0.6 mm  
MS1500

# Cooling Plate

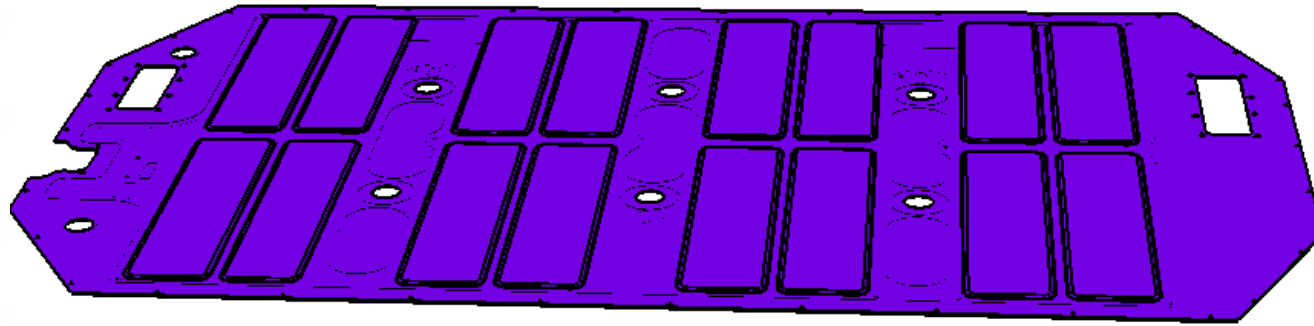

Aluminum

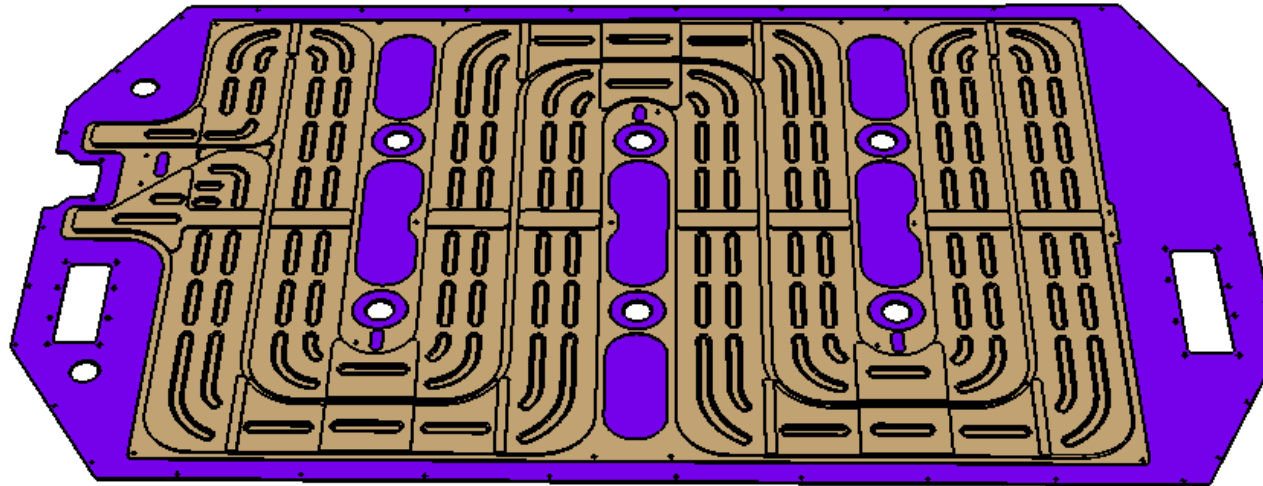

# **PERFORMANCE ASSESSMENTS**

# Load Cases Addressed

Modal	Crush Test	Underfloor Intrusion	Drop Test	Shock Test
OEM Specific	EU ECE R100 China GBT31467.3	OEM Specific	SAE J2464 China GBT31467	OEM Specific
1 <sup>st</sup> Bending & Torsional Frequencies	Quasi-static load 150 mm dia Rigid Pole	Quasi-static load 20 mm dia Round Impactor	Drop from 4.9m 15° Angle to Ground 9.8 m/s Hitting Velocity	Proof and Abuse Shock in x, y, z directions
Interaction with Overall Vehicle Modes	No Contact with Battery Modules before 100 kN	No Contact with Battery Modules before 35 kN	No Failures	No Rupture / Permanent Deformation

Static stiffness analyses were conducted initially to optimize sections and gages

# Stiffness and Modal Comparison

	Aluminum Baseline	Optimized Steel
Static Torsion, kN.mm/rad	19,146	20,021
Static Bending, kN/mm	1.9	2.6
First Torsion Mode, Hz	30	30.5
First Bending Mode, Hz	62.8	56.5

Aluminum cooling plate included in both models

For SIBES, the cooling plate was assumed to be bonded to the steel frame

# Static Torsional Stiffness

Aluminum

Steel

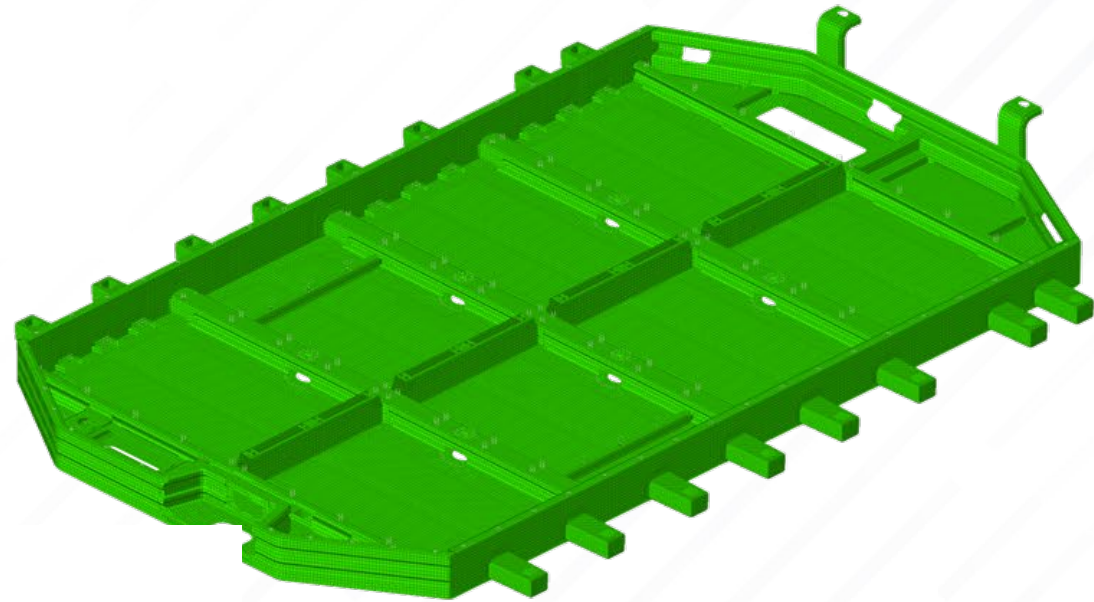
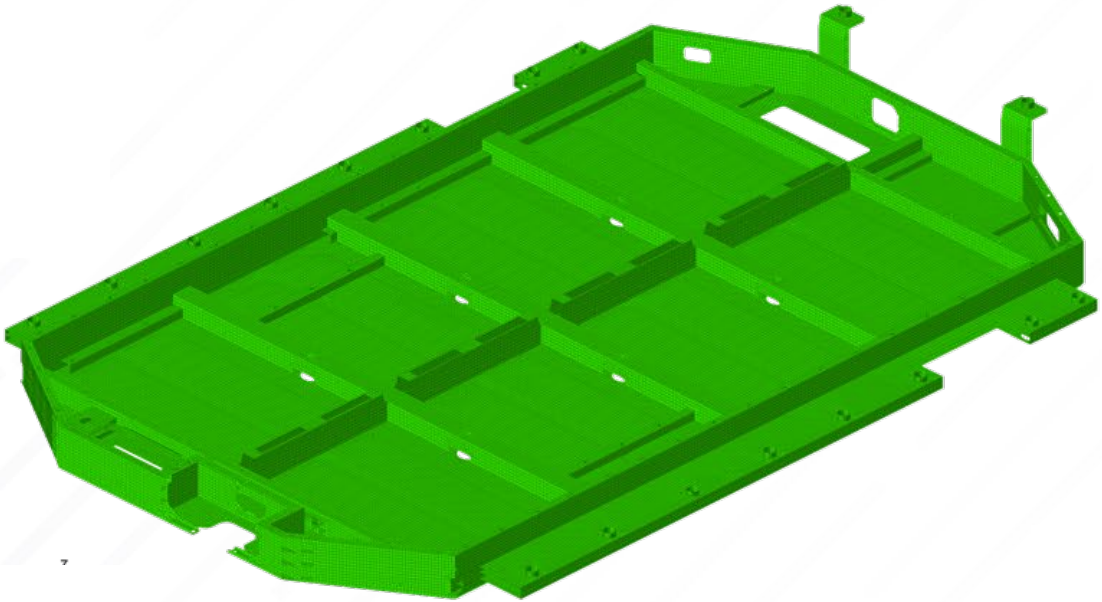

19,146 kN.mm/rad

20,021 kN.mm/rad

# Static Bending Stiffness

Aluminum

Steel

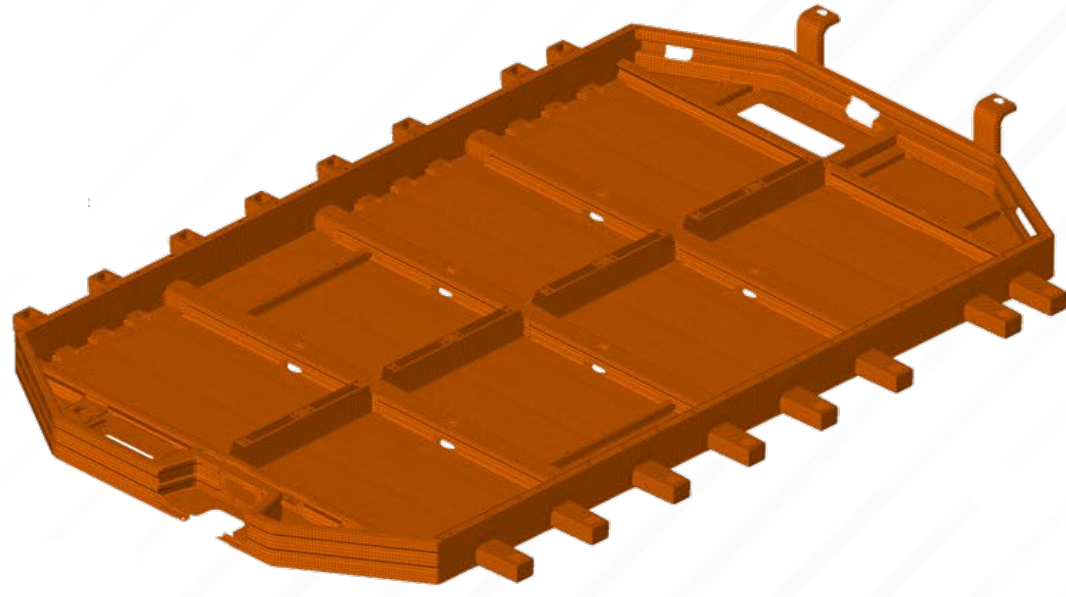
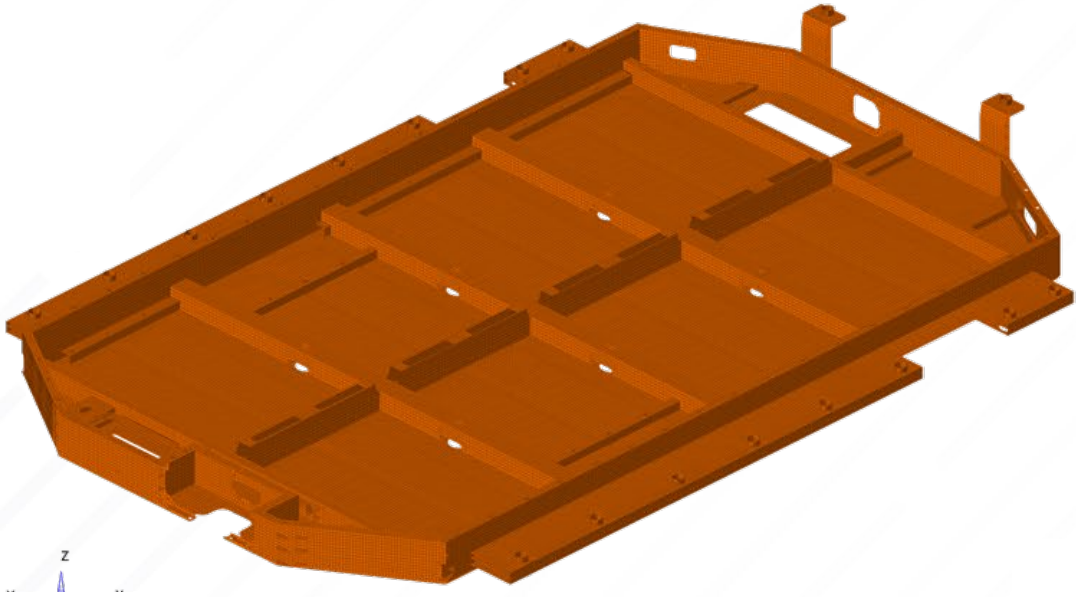

1.9 kN/mm

2.6 kN/mm

# Global Torsional Mode

Aluminum

Steel

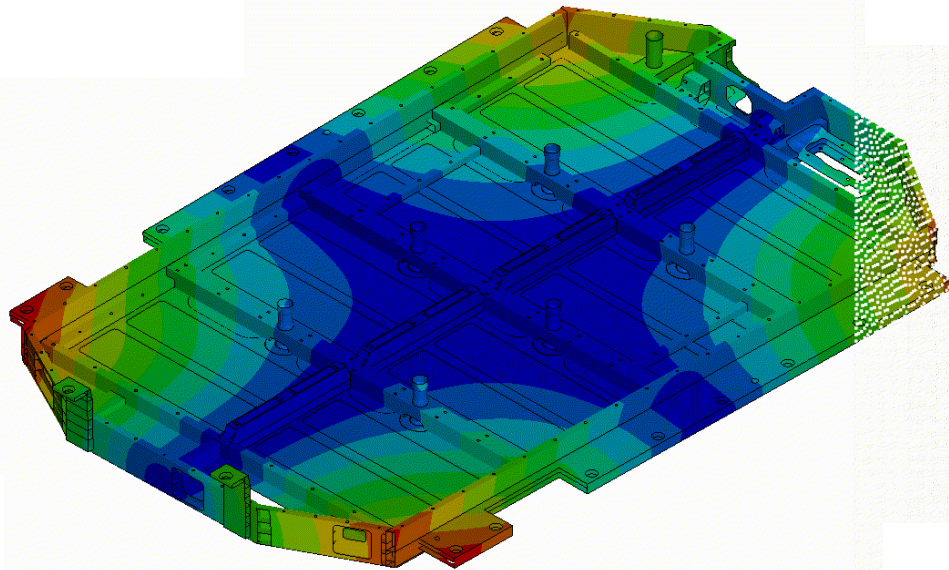

30 Hz

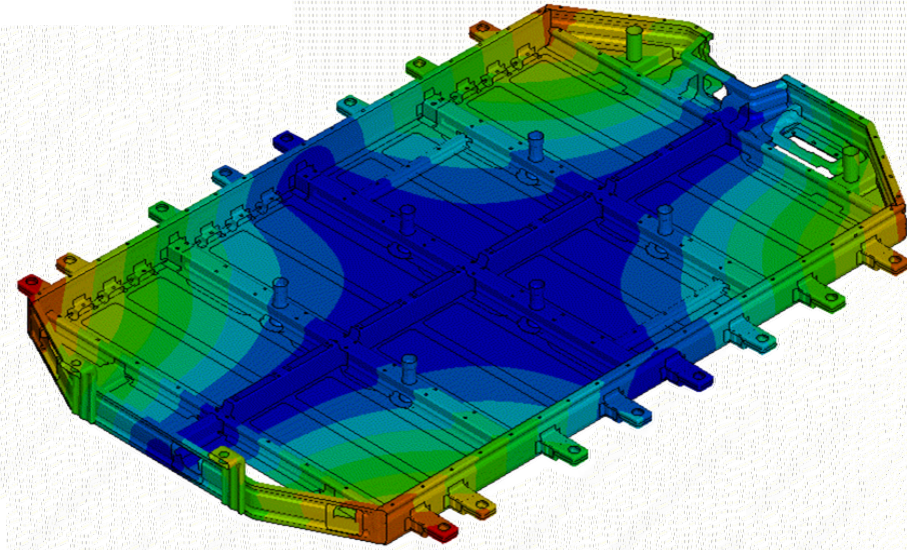

30.5 Hz

# Global Bending

Aluminum

Steel

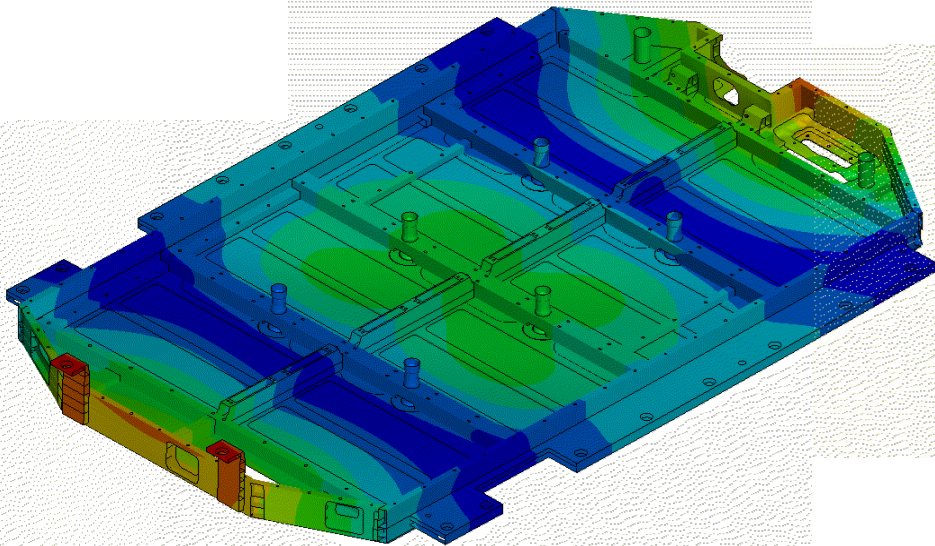

62.8 Hz

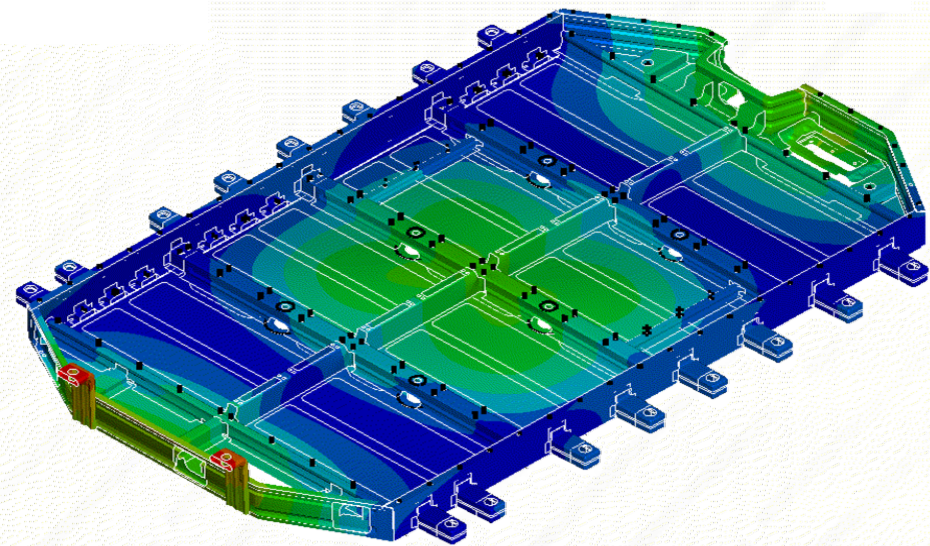

56.5 Hz

# Front Pole Crush Test

*EU ECE R100, ChinaGBT31467.3*

## Description:

- Quasi-static load.
- 150 mm diameter rigid pole crushing the battery enclosure with a displacement rate of 1 mm/s.
- Force applied at most severe location.

## Target

- Reach 100 kN force before contacting battery modules.

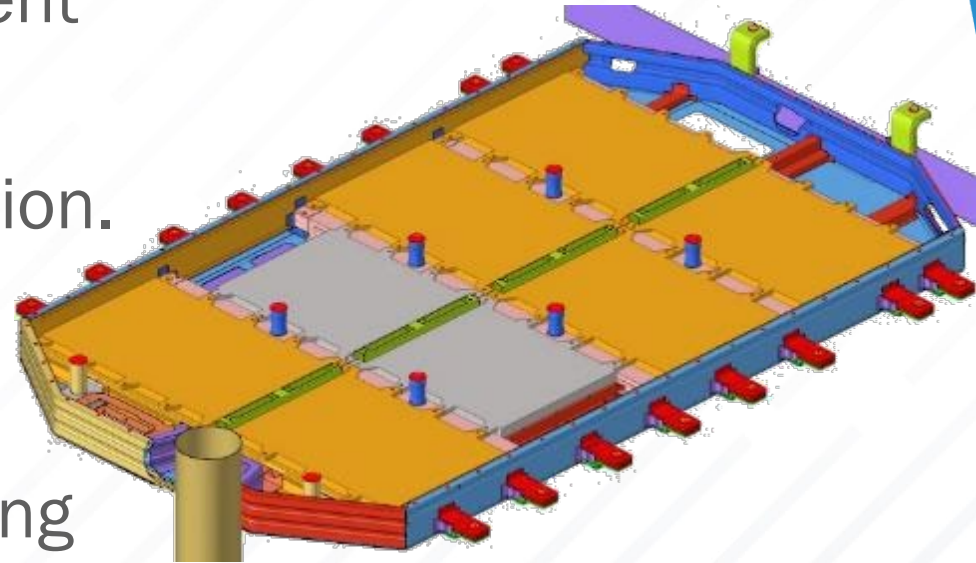

# Front Pole Crush Test Setup

Pole impacts at most severe location

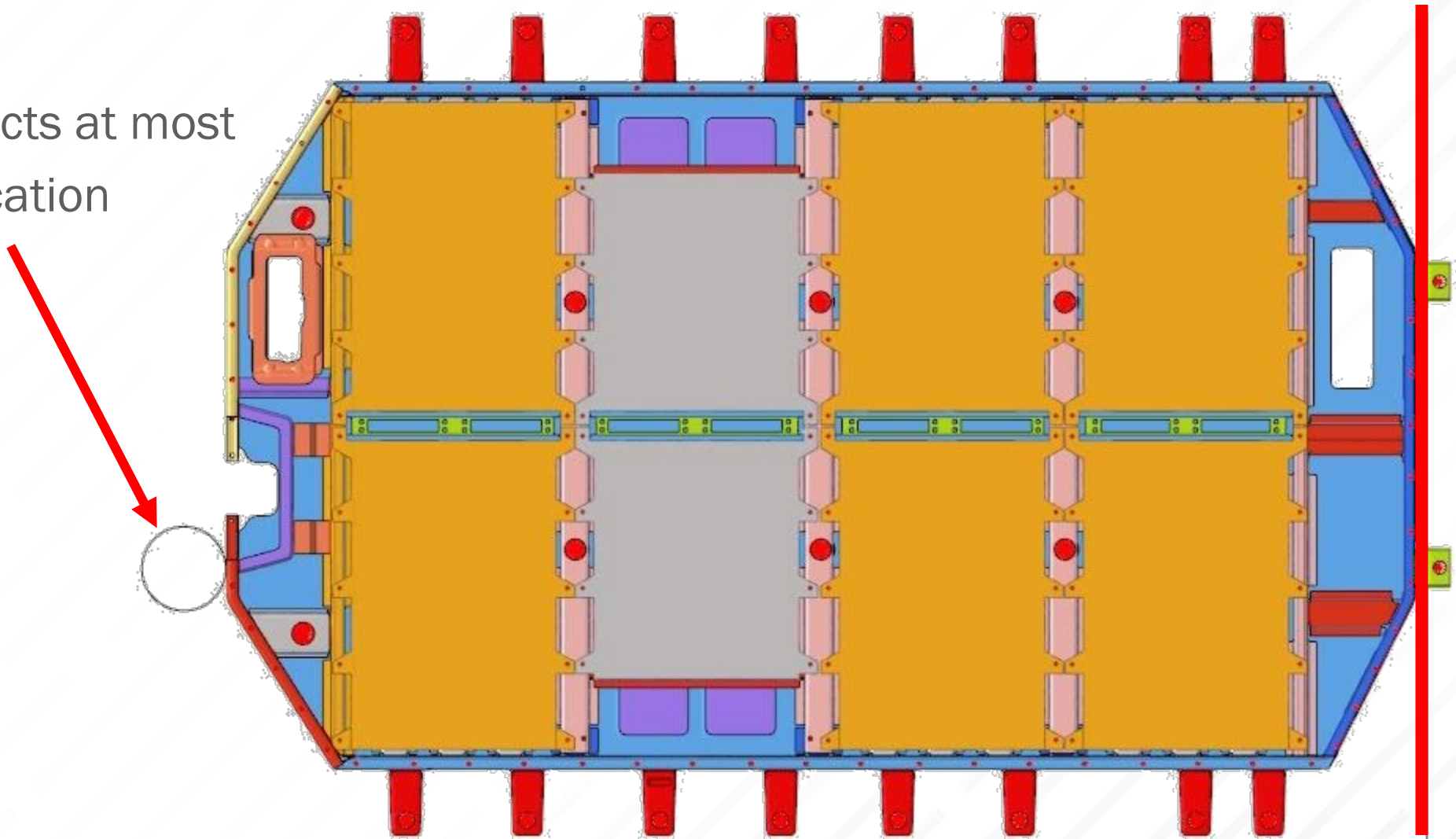

Rigid Wall

# SIBES Front Pole Crush Test

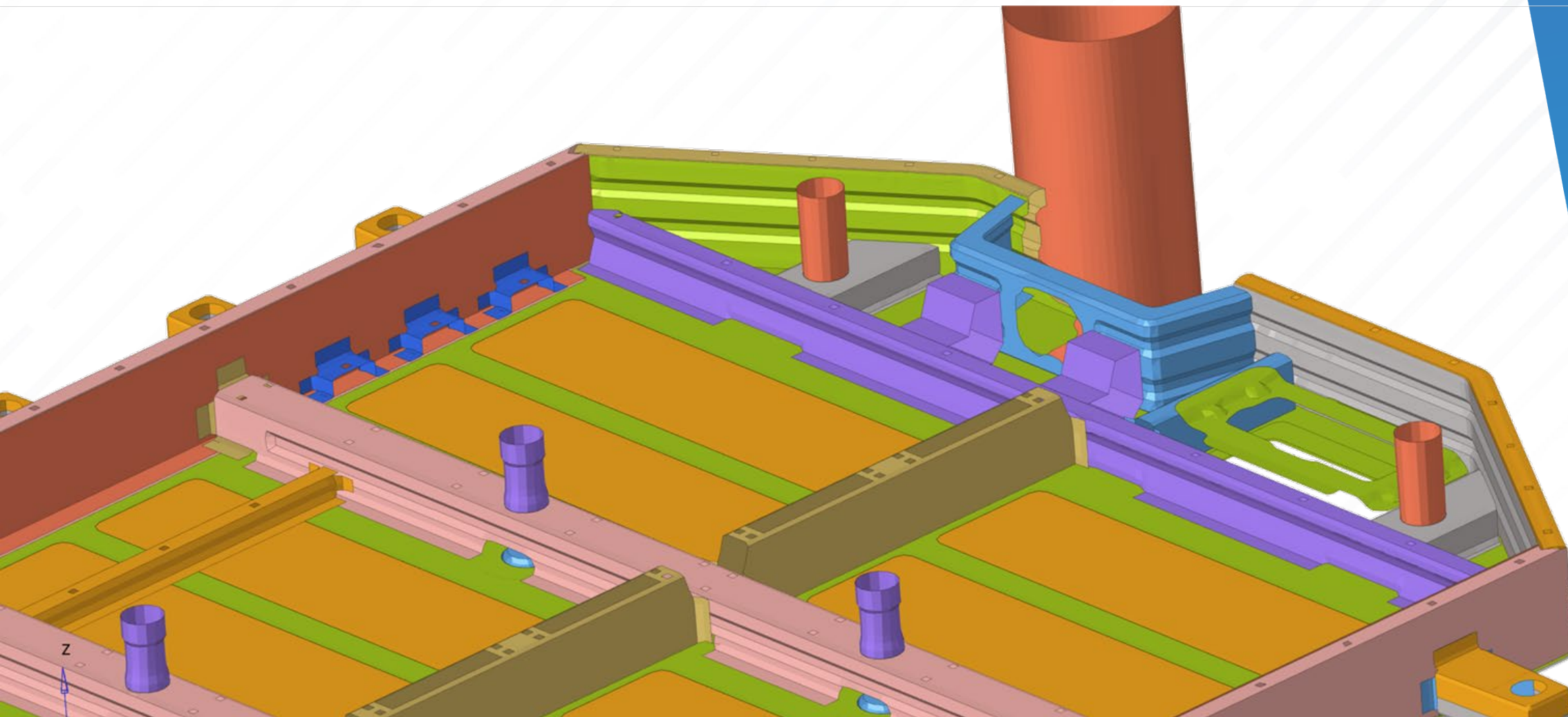

# SIBES Front Pole Crush Test

## Displacement Contour

Contour Plot  
Displacement(X)  
Analysis system

30.000
26.667
23.333
20.000
16.667
13.333
10.000
6.667
3.333
0.000
No Result

Max = 63.553

1: LS-DYNA keyword deck by LS-PrePost  
Loadcase 1 : Time = 0.000000 : Frame 1

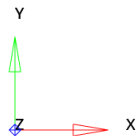
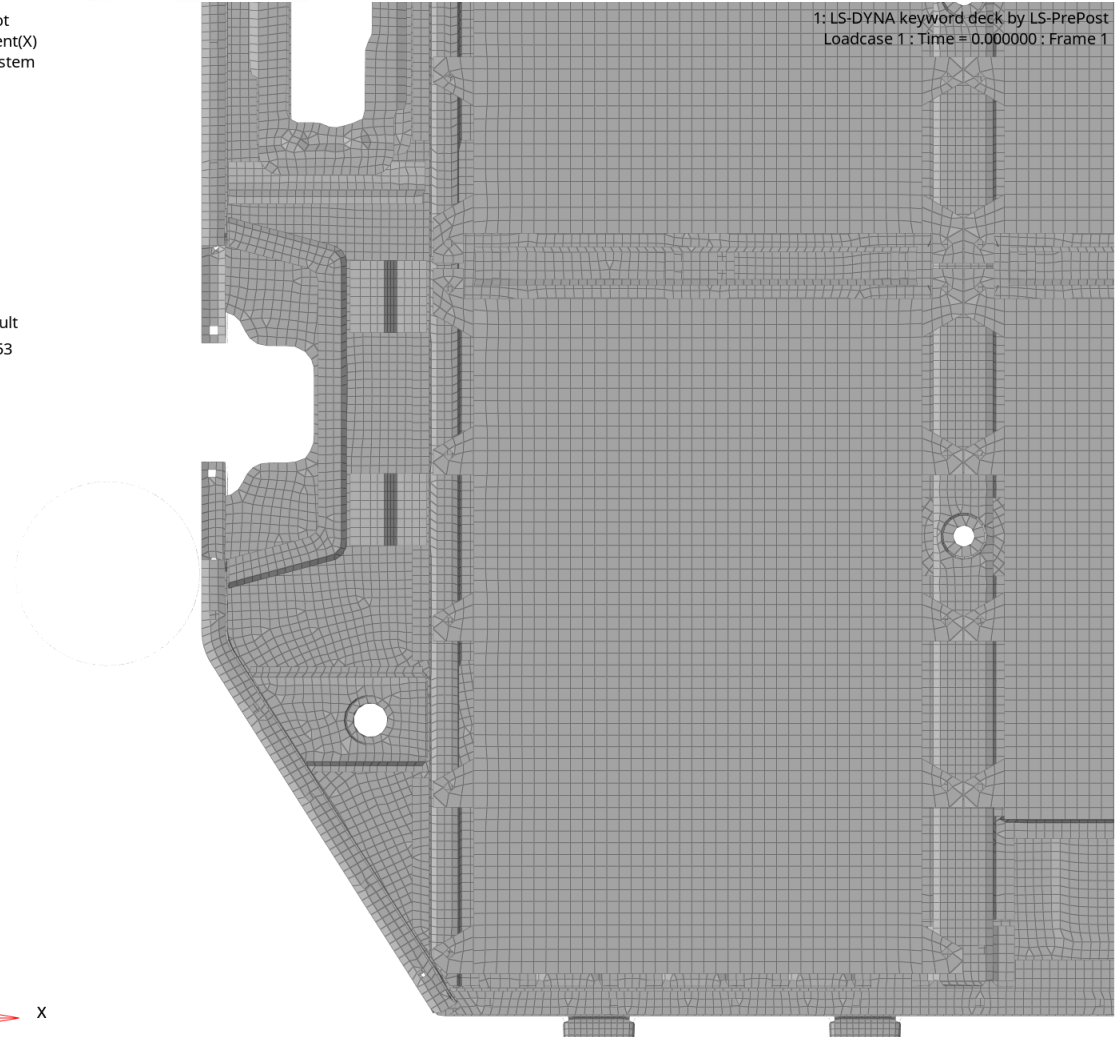

# SIBES Front Pole Crush Test

## Stress Contour

Contour Plot  
Stress(vonMises, Average)  
Elemental system  
Simple Average

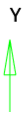
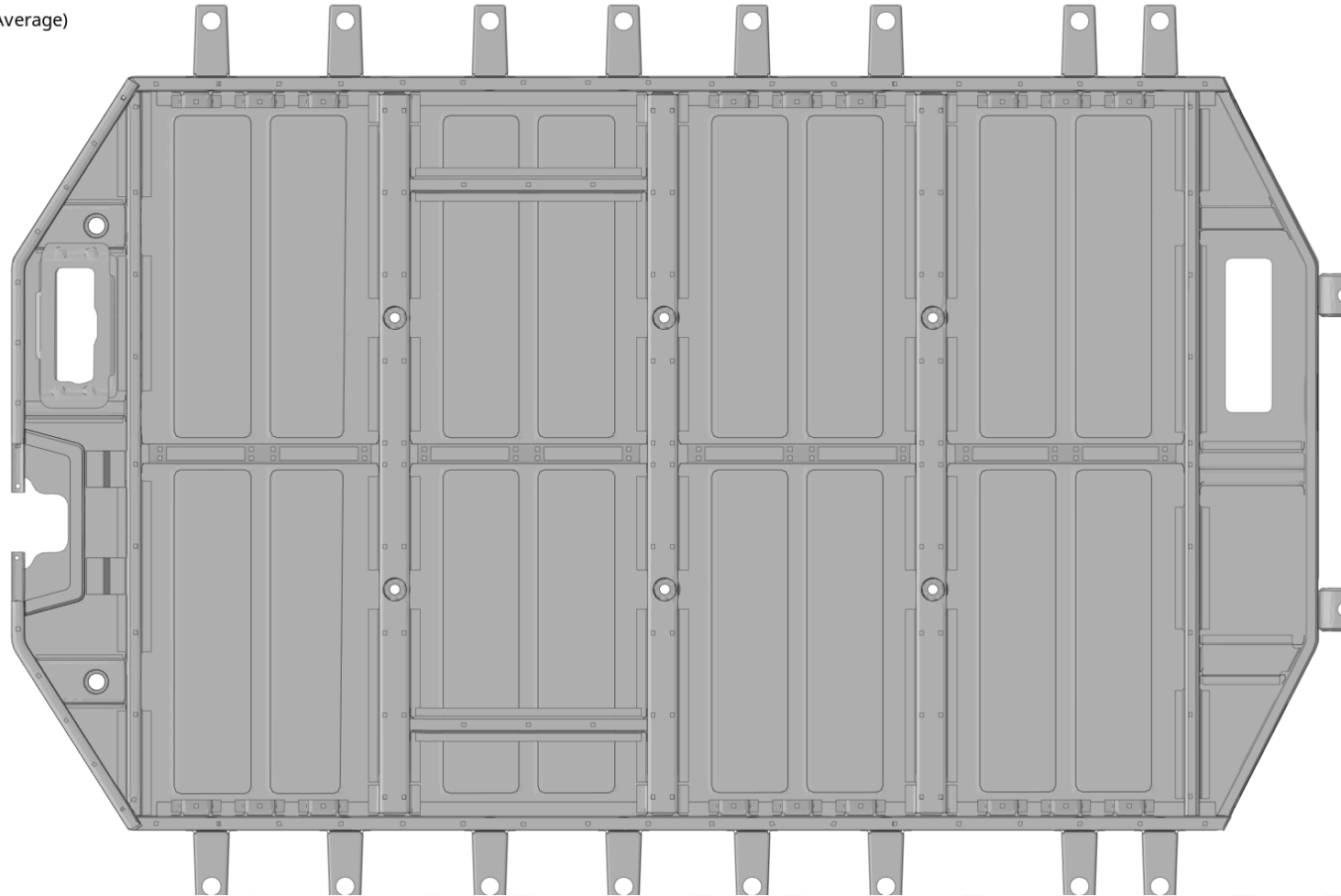
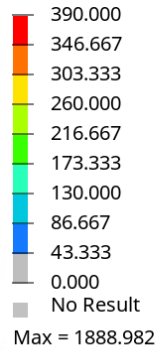

# SIBES Front Pole Crush Test

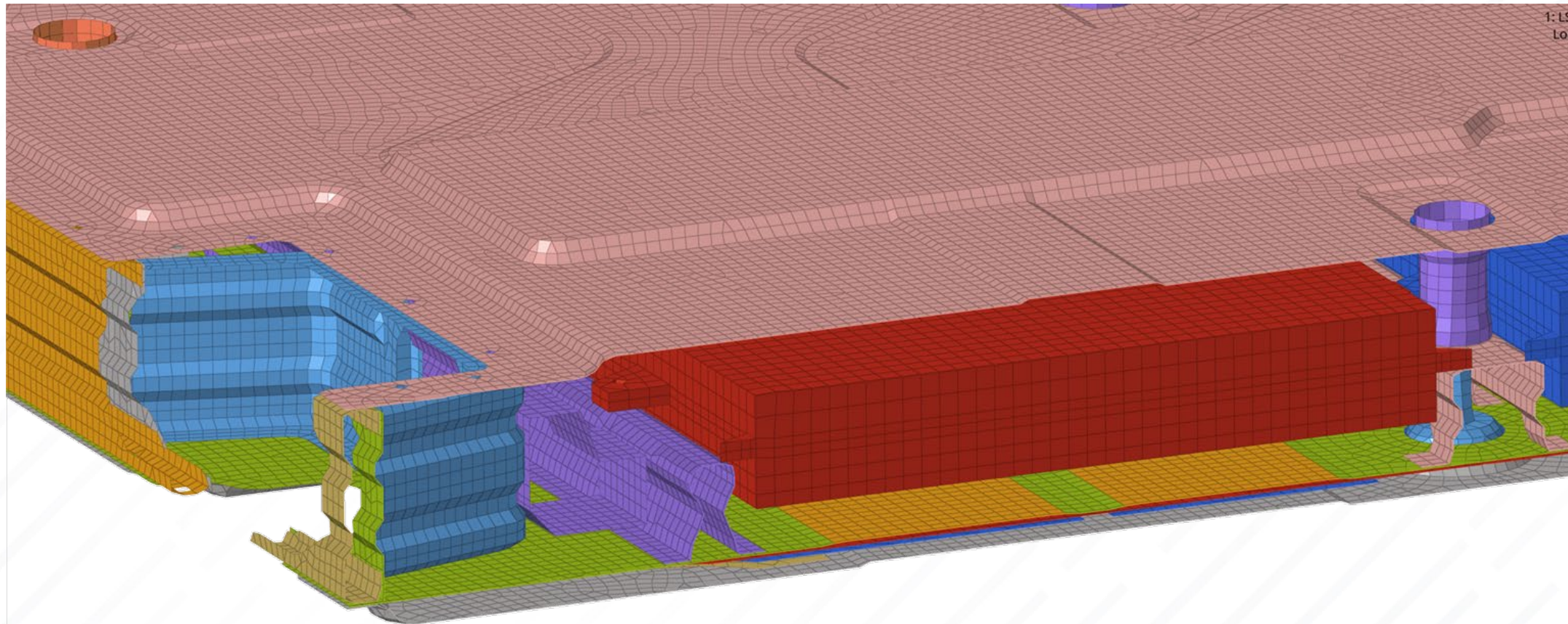

# Front Pole: Steel vs Aluminum

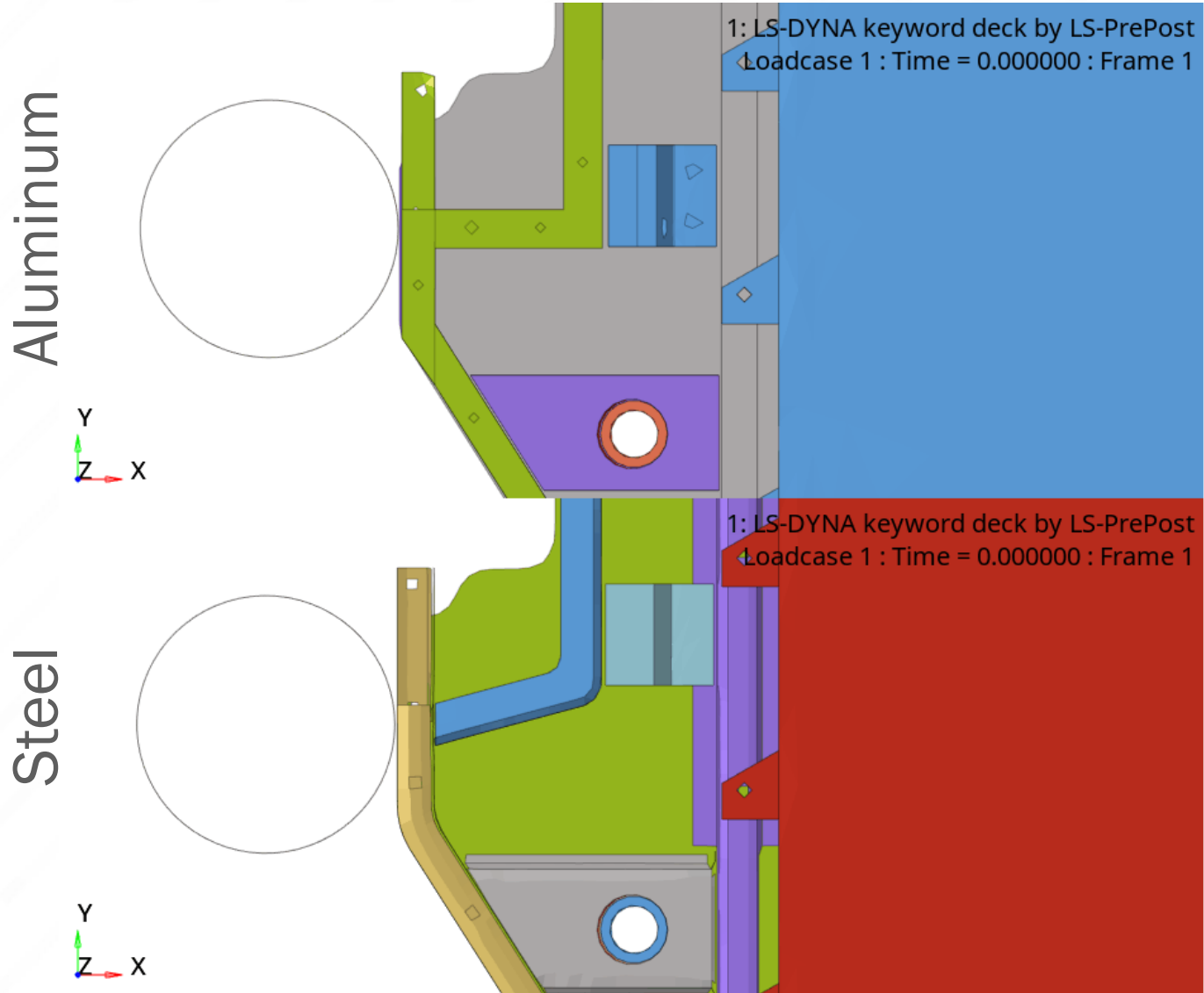

# Front Pole Crush Simulation Summary

- The steel concept managed the front pole crush by absorbing the energy through geometry, grade, and gage. This is in contrast to the baseline aluminum design where the emphasis was on strength to stop the pole with little deformation.
- The front pole was applied to the most severe location, and the steel concept met the required 100 kN crush force with no yielding or excessive plastic strain in the frame front crossmember.
- The battery modules will not be contacted in either case.

# Performance Scorecard

Metric	Aluminum	SIBES	Comment
Total Mass, kg	91.3	95.3	+ 4 kg (+ 4.4% ) Below 10%
Bending Stiffness, kN/mm	1.9	2.6	+ 36.8%
Torsional Stiffness, kN.mm/rad	19,146	20,146	+ 5.2%
First Bending Frequency, Hz	62.8	56.5	- 10% (mode comparable)
First Torsional Frequency, Hz	30	30.5	+1.7%
Side Pole Crush	Good	Good	No contact with modules
Front Pole Crush	Good	Good	No contact with modules
Underbody Impact	Good	Good	No contact with modules
Shock Test	Good	Good	Minor stress concentrations
Drop Test	Good	Good	No failures

# Conclusion

- The study team managed to demonstrate an environmentally friendly steel-intensive battery enclosure that can compete with an aluminum design on mass and performance.
- It is important to develop the enclosure structure in unison with the vehicle body structure to ensure proper integration, optimize crash energy absorption, and guarantee battery module protection.
- The wide range of steel grades currently available to automotive engineers allow them to achieve a good balance between structural performance, manufacturability, and cost.

## For More Information

Tom Wormald

ArcelorMittal

[tom.wormald@arcelormittal.com](mailto:tom.wormald@arcelormittal.com)

Yu-Wei Wang, Ph.D.

Cleveland-Cliffs, Inc.

[Yu-Wei.Wang@ClevelandCliffs.com](mailto:Yu-Wei.Wang@ClevelandCliffs.com)