

GREAT DESIGNS IN
STEEL

2021 CADILLAC ESCALADE
STRUCTURE REVIEW

Jeff McCormick
General Motors

VEHICLE INTRODUCTION

- + New Dimensions
- + Material Utilization
- + Safety Strategies
- + Reduced Cabin Noise
- + Ride and Structural Feel



GDIS

LARGEST AND LONGEST ESCALADE EVER

+ NEW ARCHITECTURE ENABLES THE FREEDOM TO EXPAND YOUR ENTOURAGE

124 mm longer wheelbase Escalade
180 mm longer overall Escalade



1,948
mm

5,382 mm
Cadillac Escalade

104 mm longer wheelbase Escalade ESV
66 mm longer overall Escalade ESV



1,940
mm

5,763 mm
Cadillac Escalade ESV

ARCHITECTURE SHARING STRATEGY

Escalade



Escalade ESV

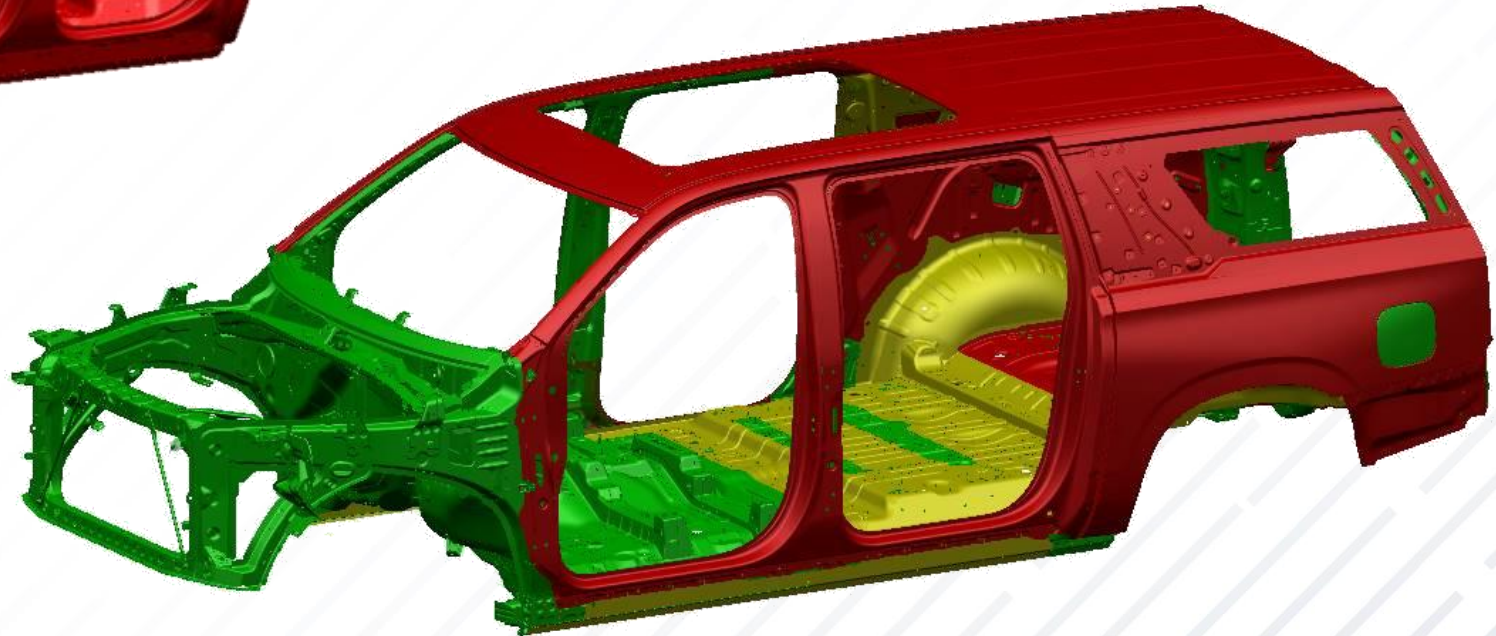

- Shared
- Modified
- New

Escalade Optimized Material Gage and Grade

PREVIOUS GENERATION

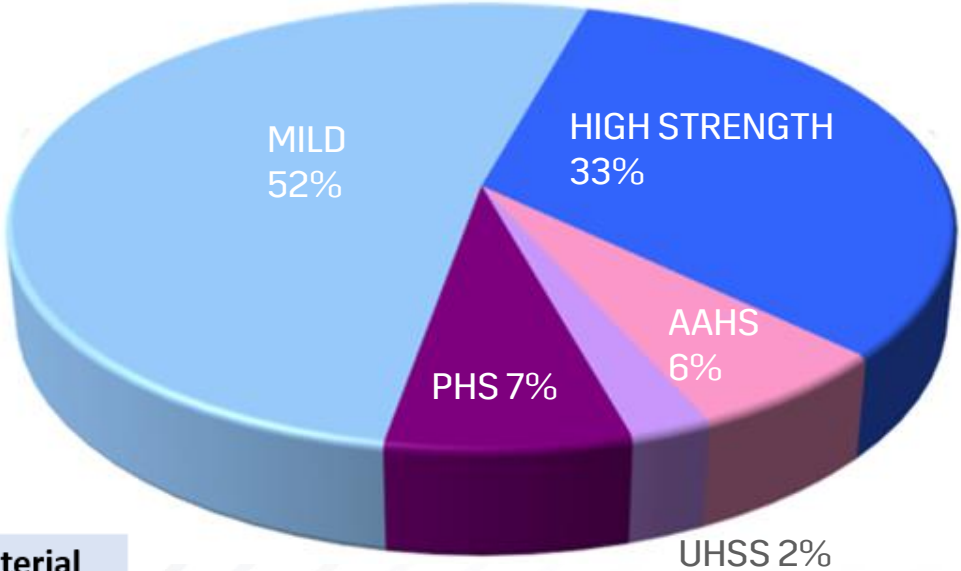

2021 ESCALADE

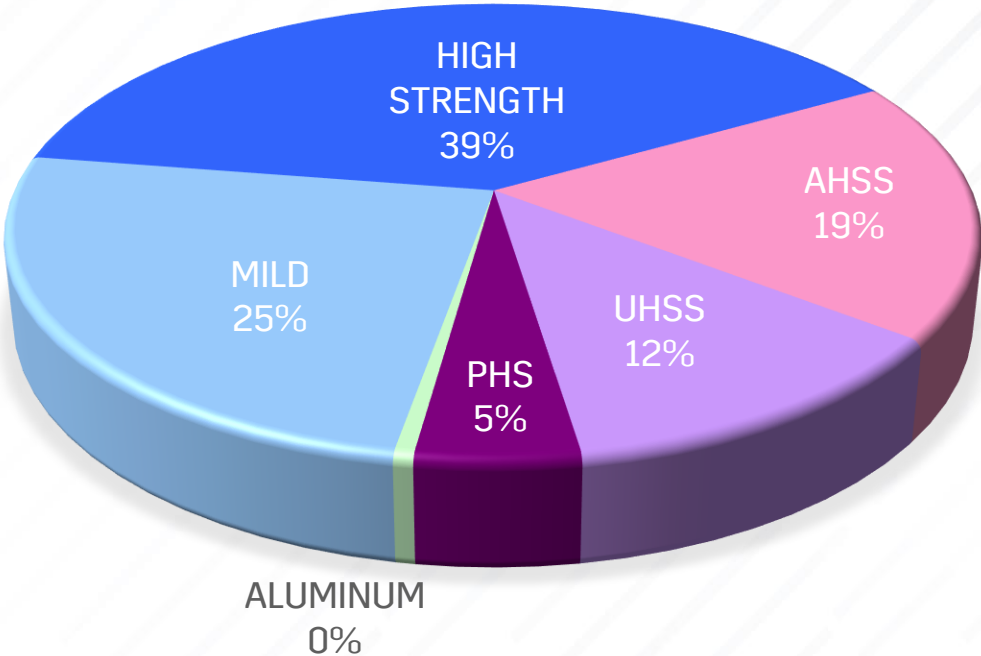

Material Strength
Low
High
AHSS
Stainless
UHSS
PHS
Aluminum

- + Expanded use of HSS
- + Strategically placed UHSS/AHSS for occupant protection



- + Enabled increased use of lightweight panels
- + Higher gages used where stiffness most needed

MILD STEEL USAGE COMPARISON

Previous
Generation

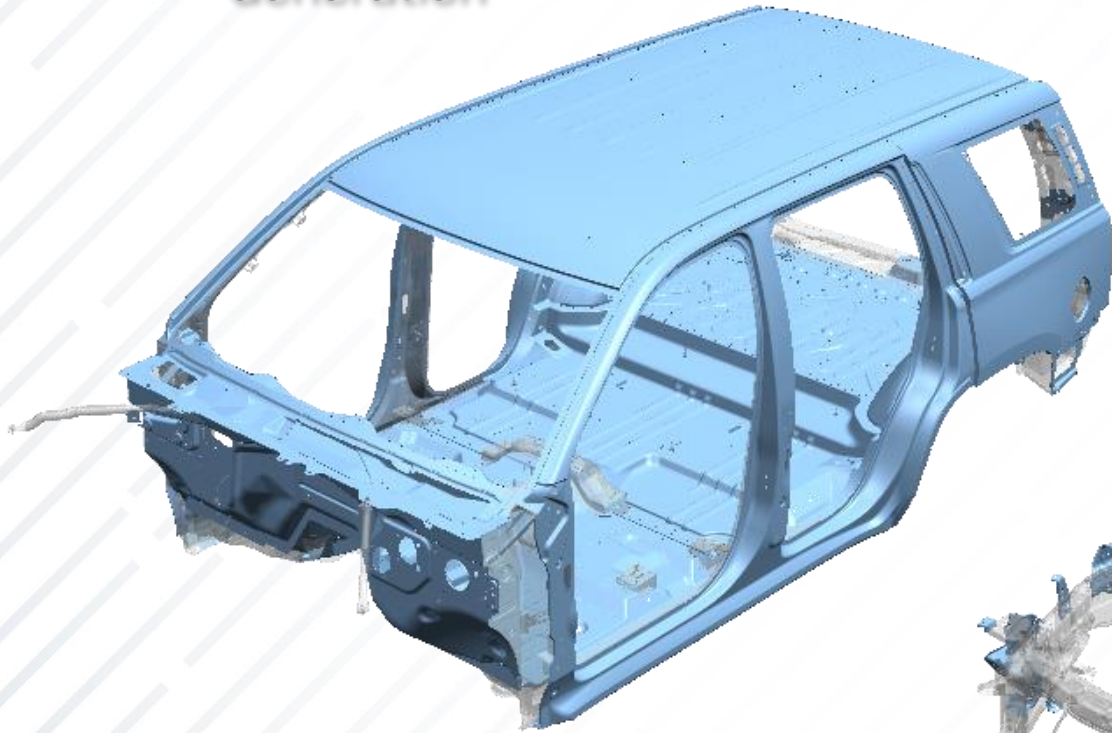

New Cadillac
Escalade

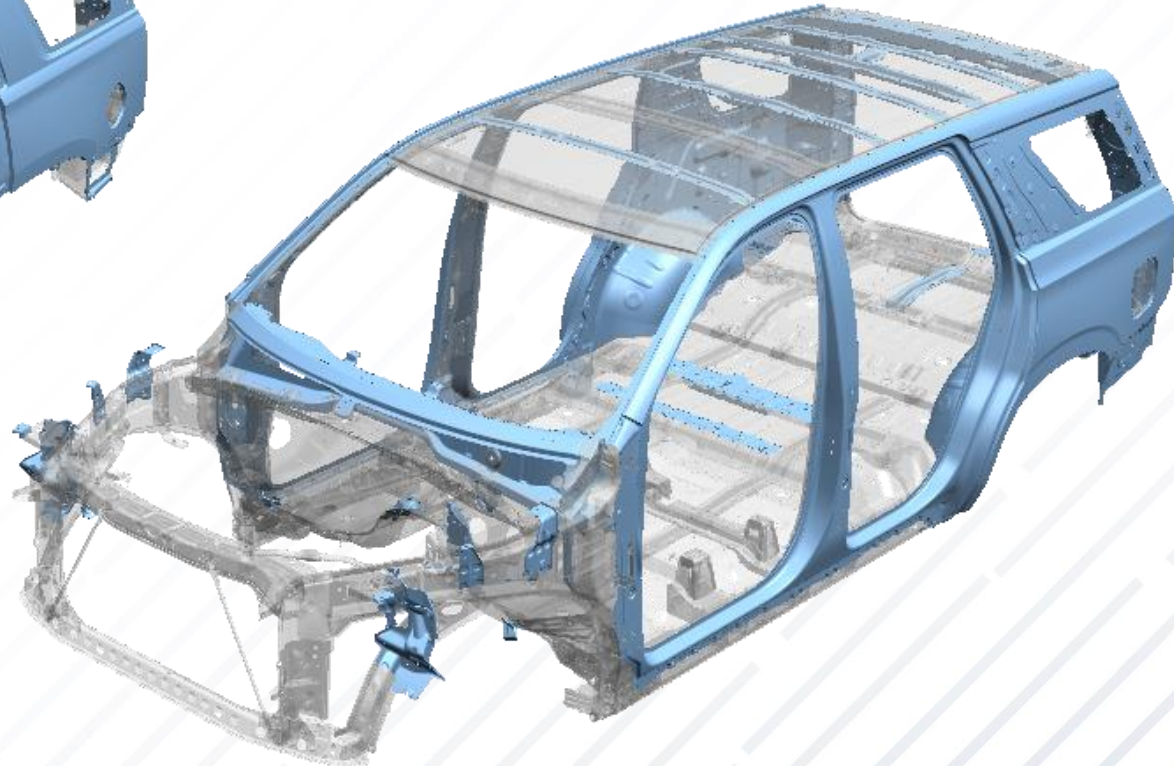

HIGH STRENGTH STEEL USAGE COMPARISON

Previous
Generation

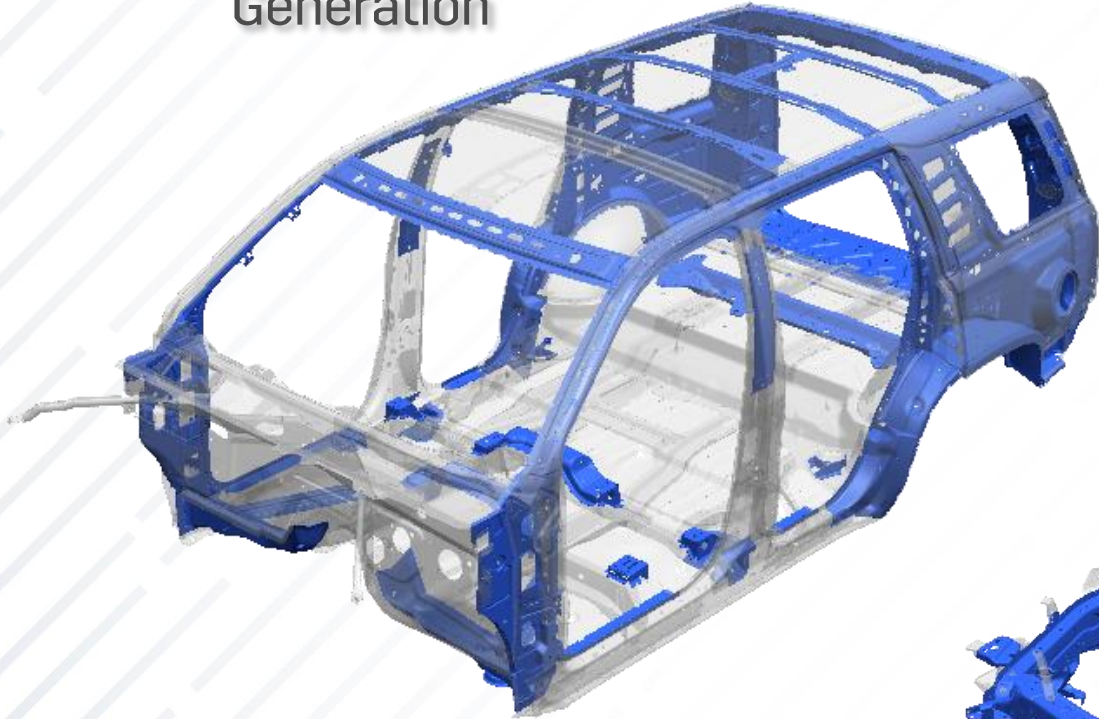

New Cadillac
Escalade

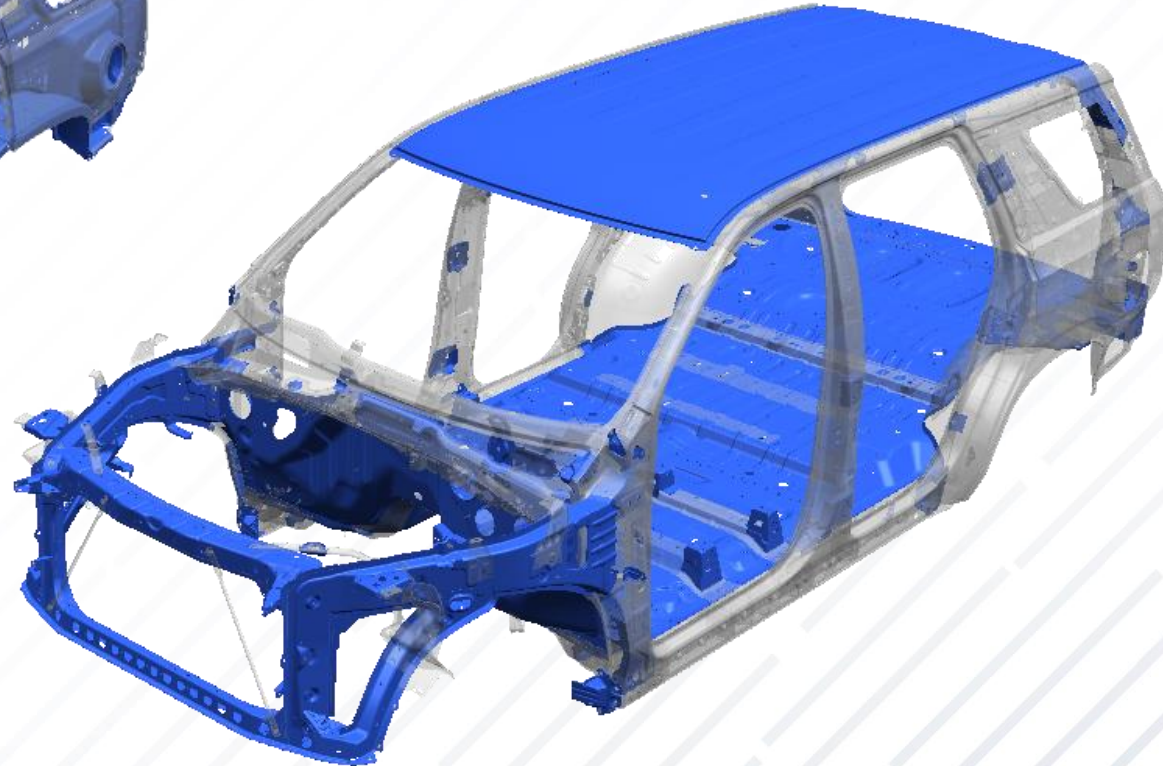

AHSS STEEL USAGE COMPARISON

Previous
Generation

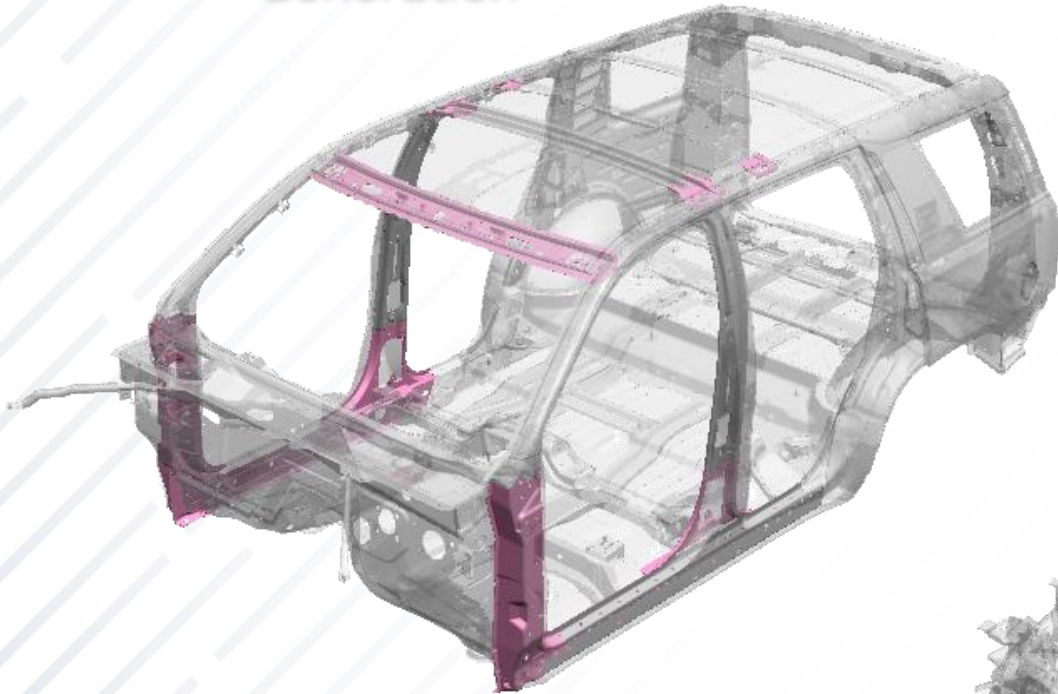

New Cadillac
Escalade

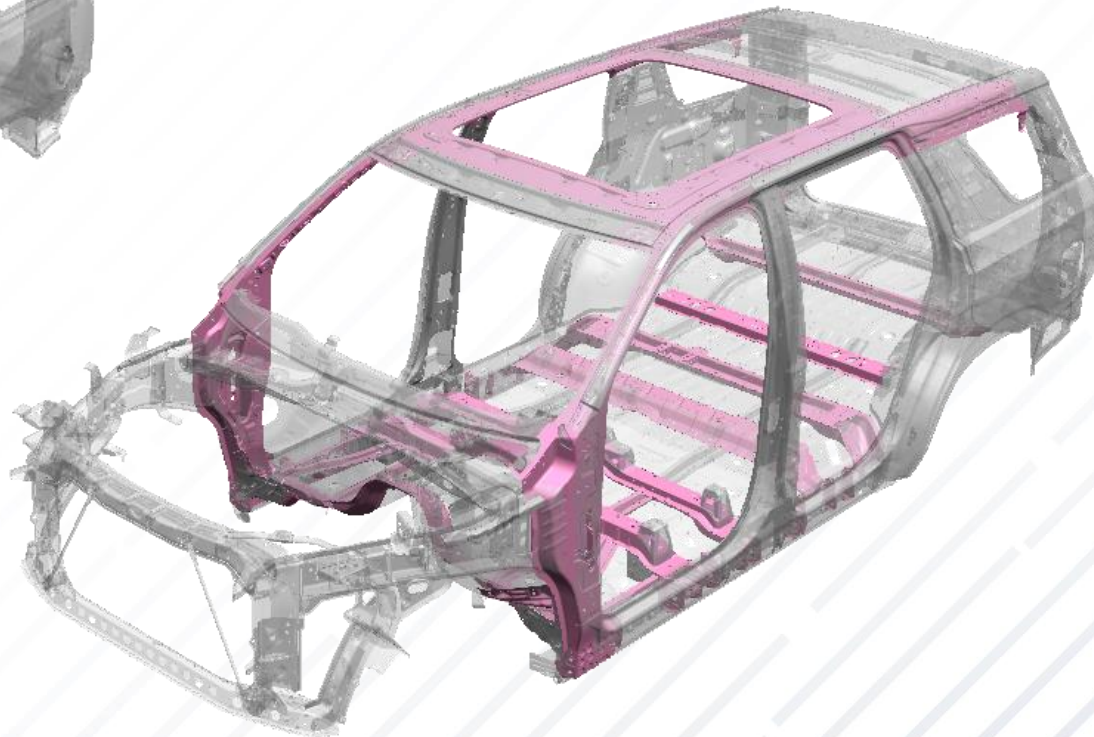

UHSS USAGE COMPARISON

Previous
Generation

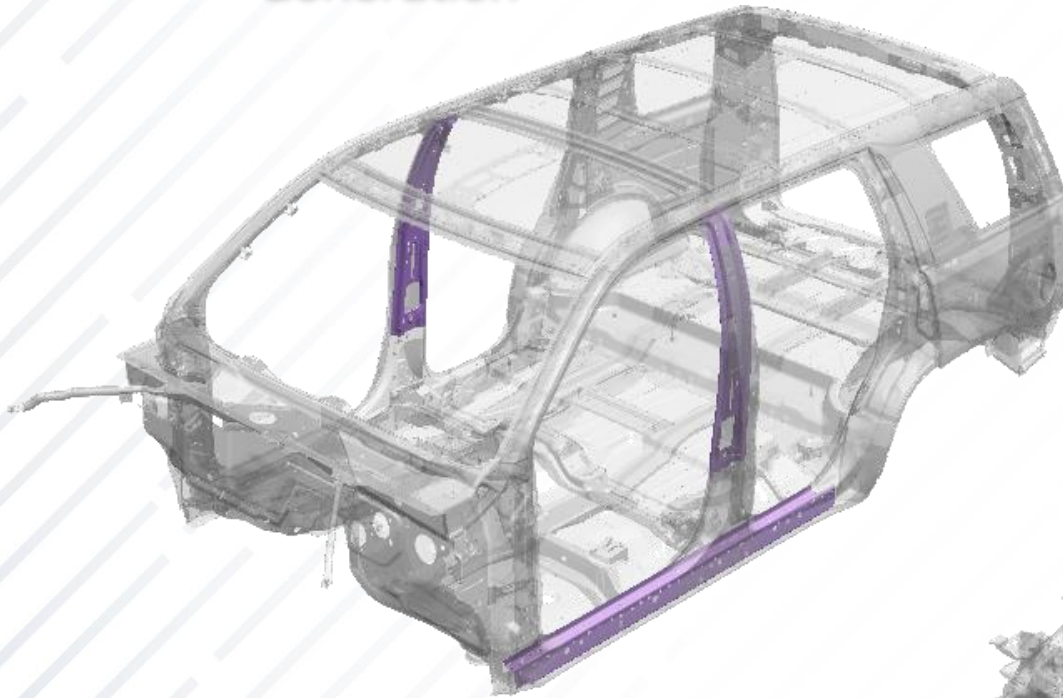

New Cadillac
Escalade

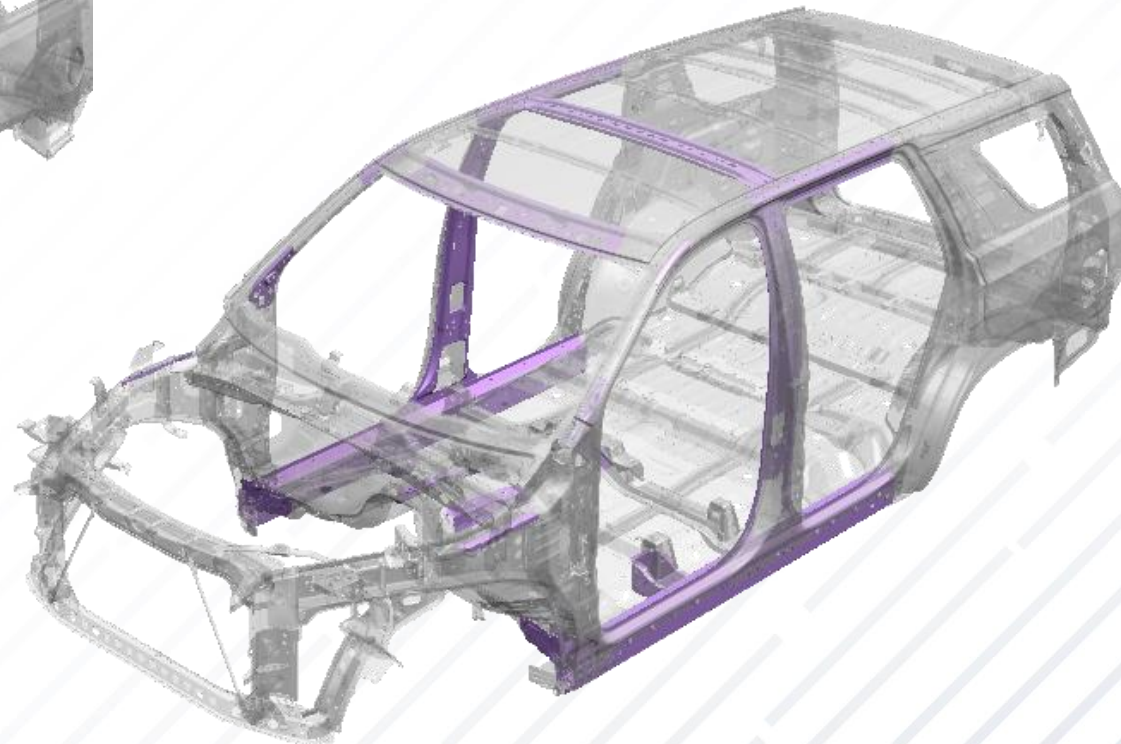

PHS STEEL USAGE COMPARISON

Previous
Generation



New Cadillac
Escalade

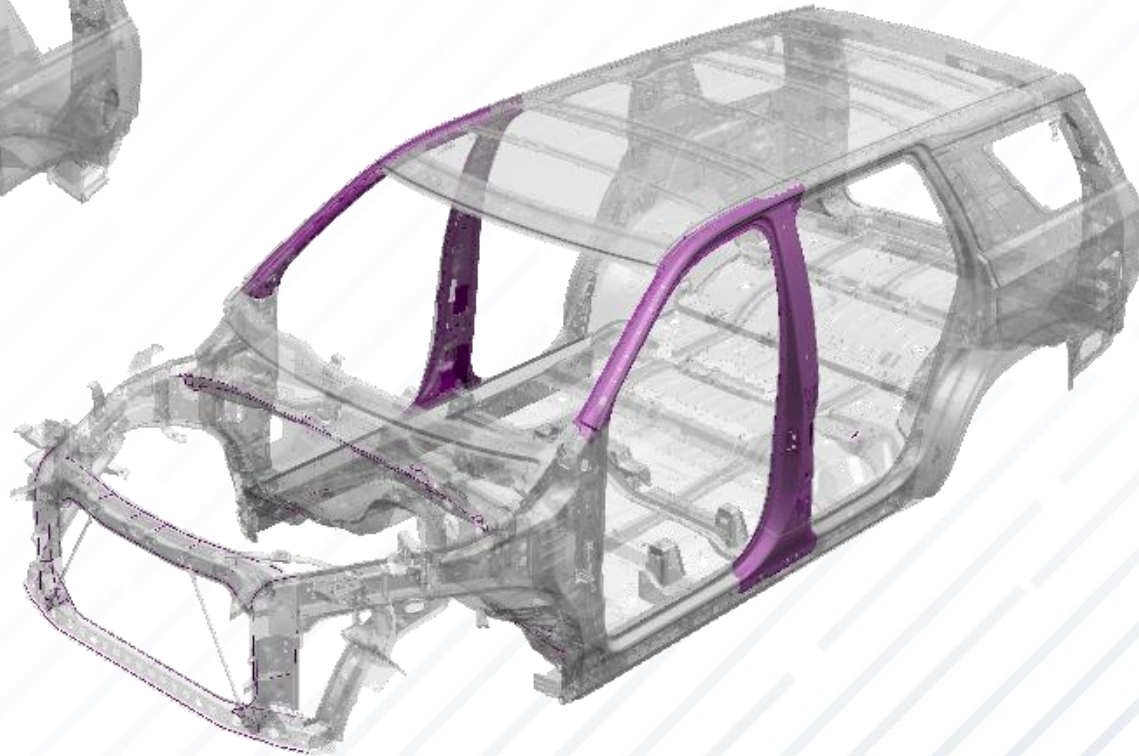

New Cadillac Escalade – Roof Rail Inner (Gen 3 steel)

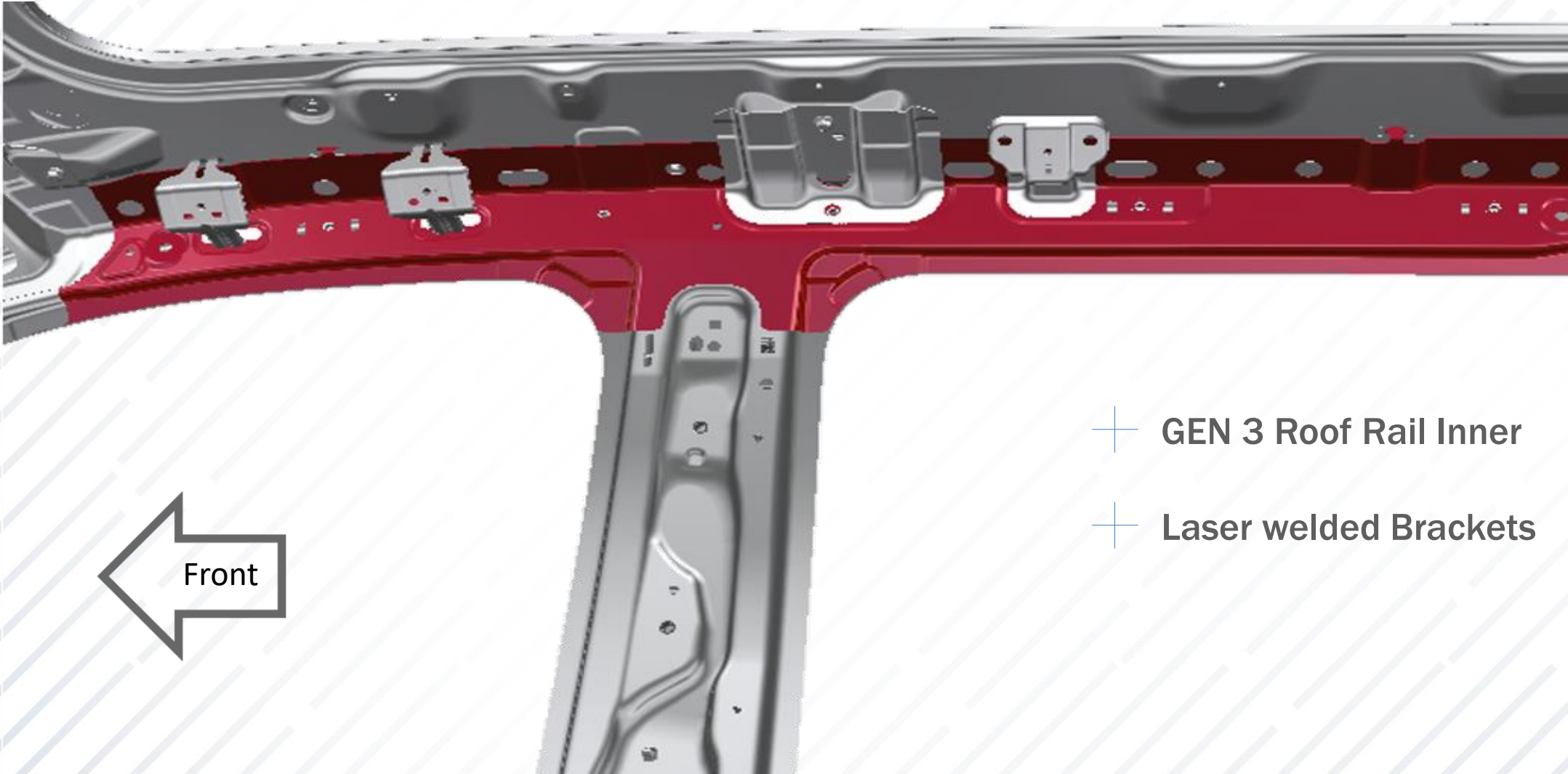

- + GEN 3 Roof Rail Inner
- + Laser welded Brackets

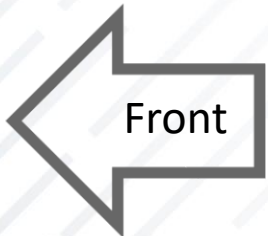

Thickness = 0.60 mm
Thickness = 0.65 mm

LIGHT WEIGHTING ENABLED

New Cadillac Escalade

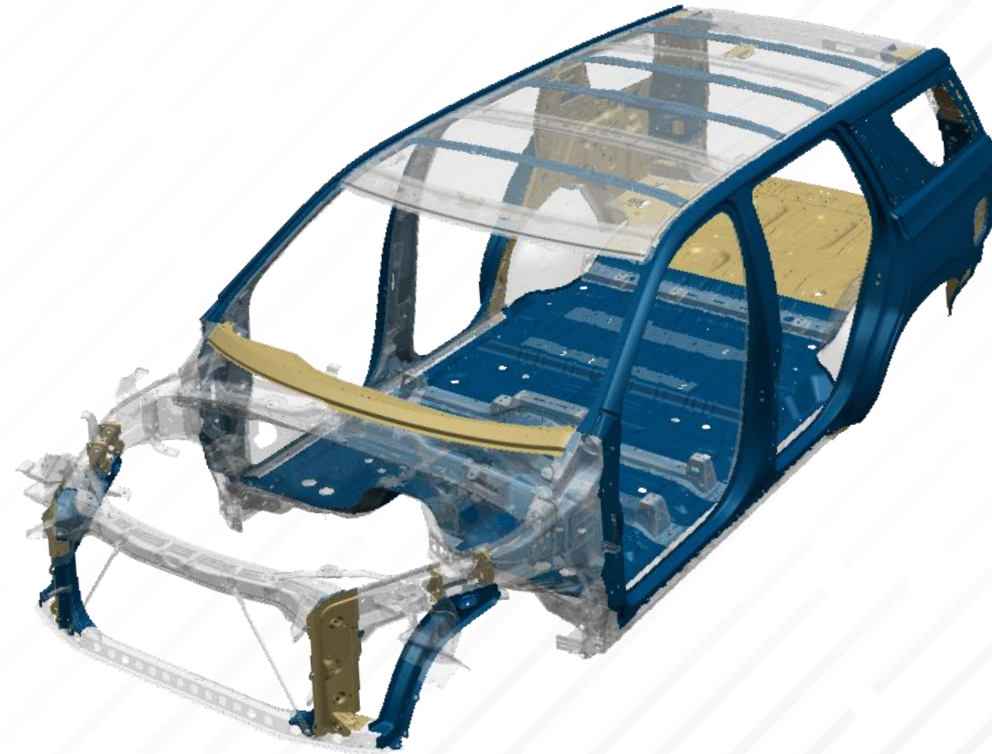

Previous Generation

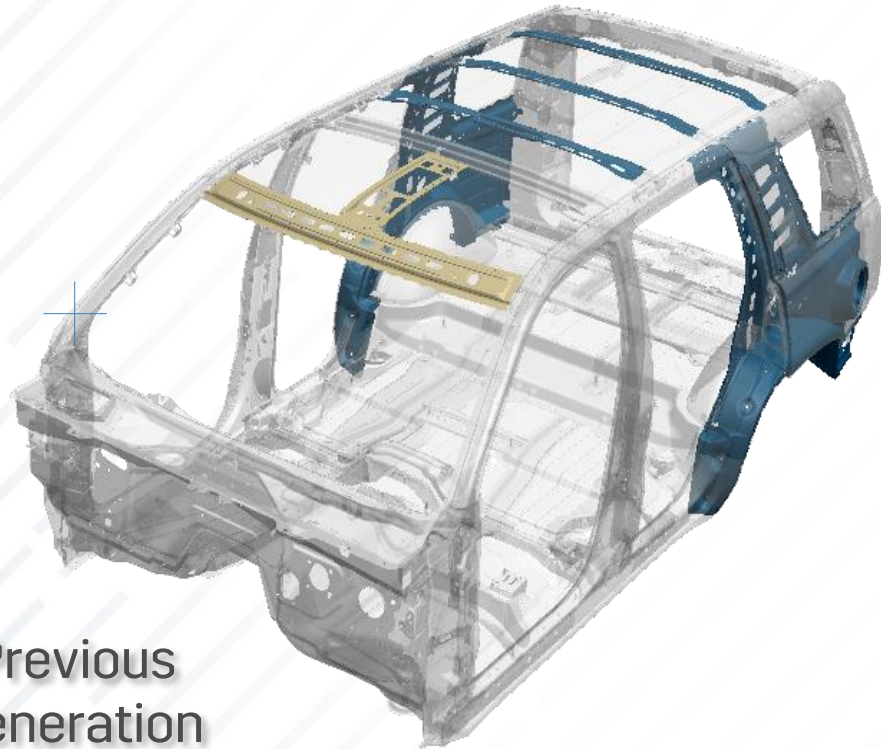

The New Cadillac Escalade body structure was tuned to balance high strength steel use with lower gauge mild steel panels.

SAFETY

- + Collision Energy Management
- + Every Seating Position

PROTECTION

GDIS



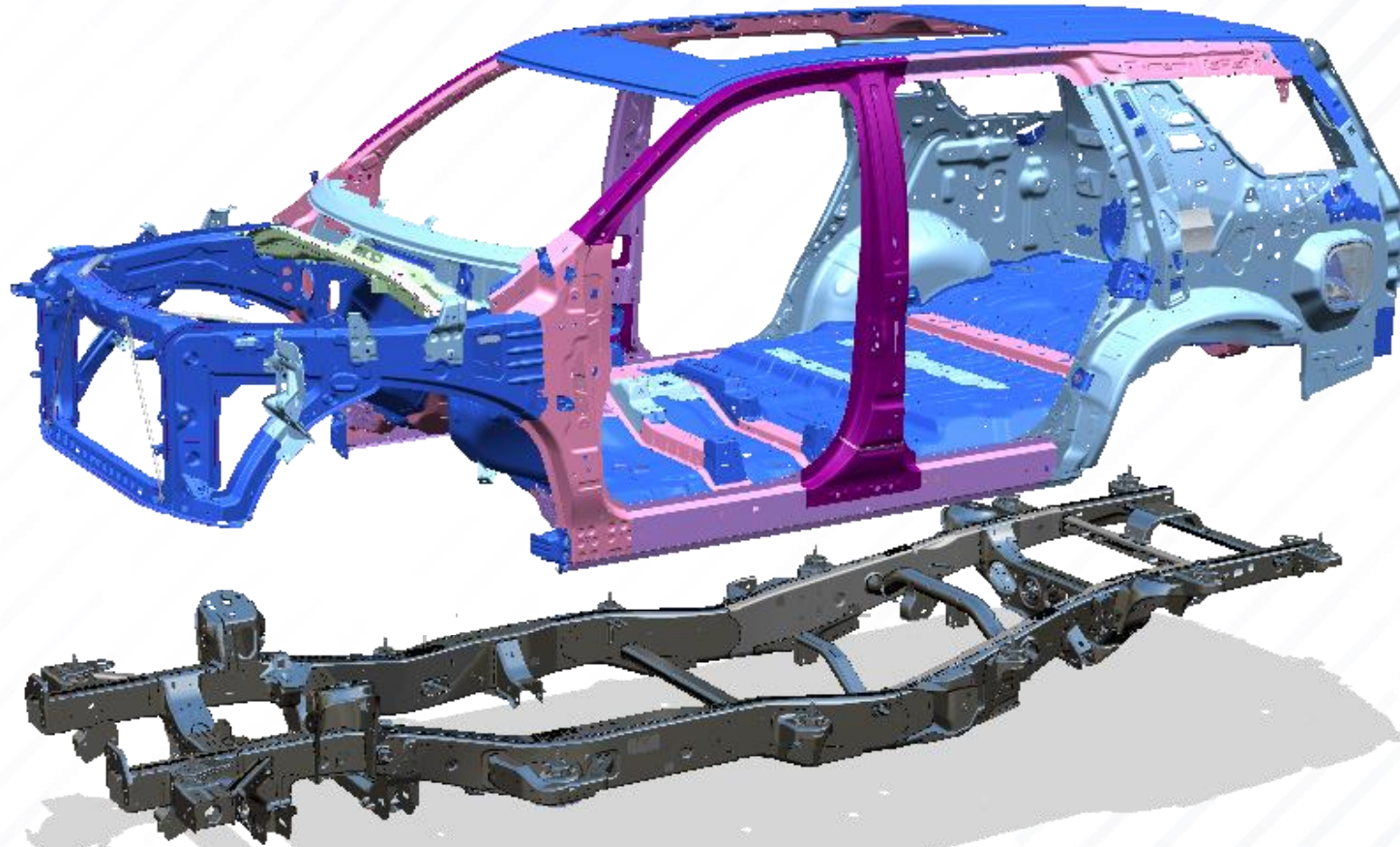

Material Strength

Low

High

AHSS

Stainless

UHSS

PHS

Aluminum

ESCALADE MATERIAL STRATEGY

PHS A-pillar

Reinforcement designed to create a strong upper load path for front impact and roof strength

PHS B-pillar

Reinforcement (tailor rolled blank) designed for side impact and roof strength

Material Strength
Low
High
AHSS
Stainless
UHSS
PHS
Aluminum

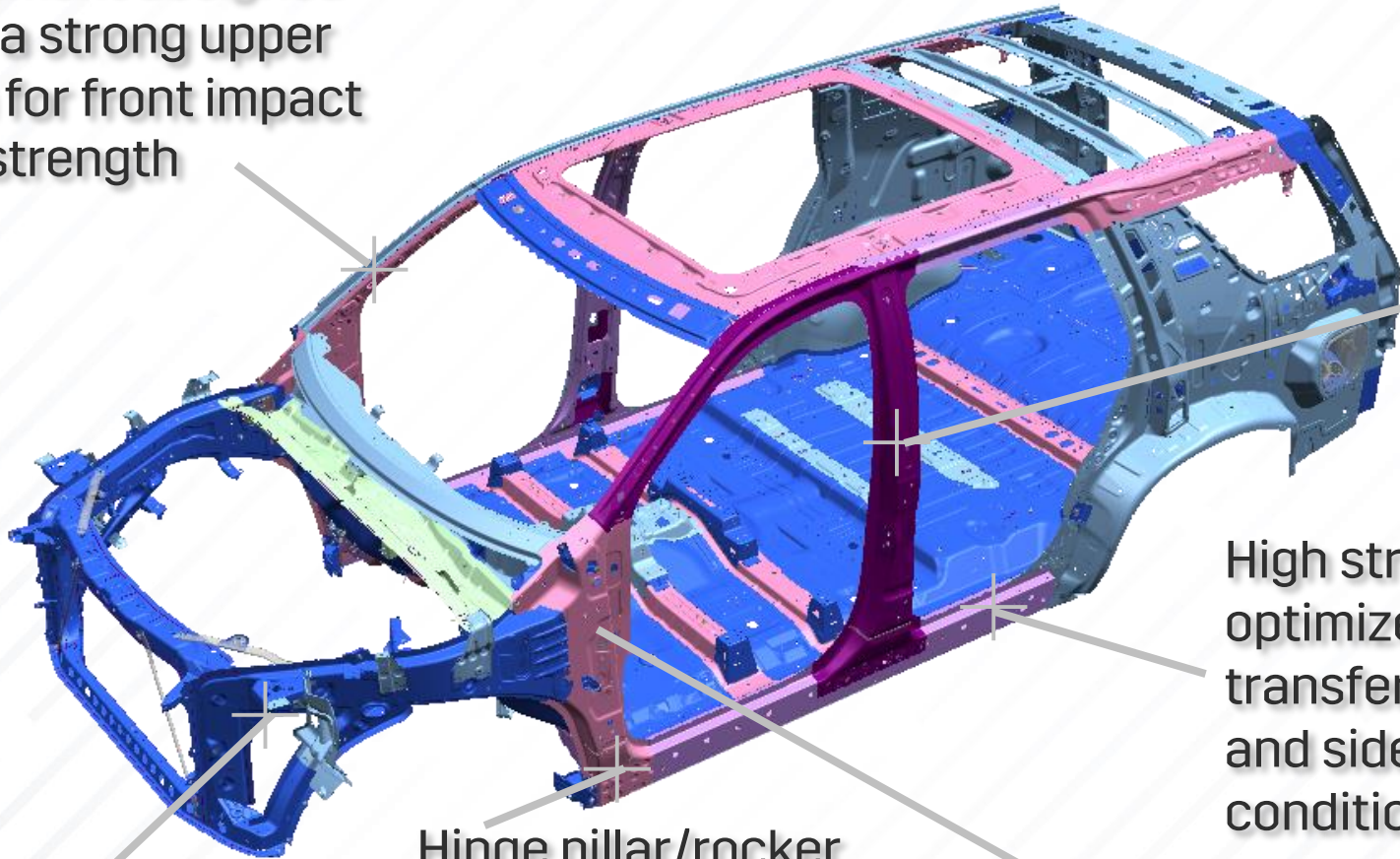

High strength rocker with optimized reinforcements to transfer load in both front and side impact test conditions

High strength front structure for energy absorption and pitch management

Hinge pillar/rocker corner reinforced for load distribution and optimal energy absorption



Reinforced occupant cage for load distribution and intrusion mitigation

FRONTAL IMPACT BIW LOAD PATHS

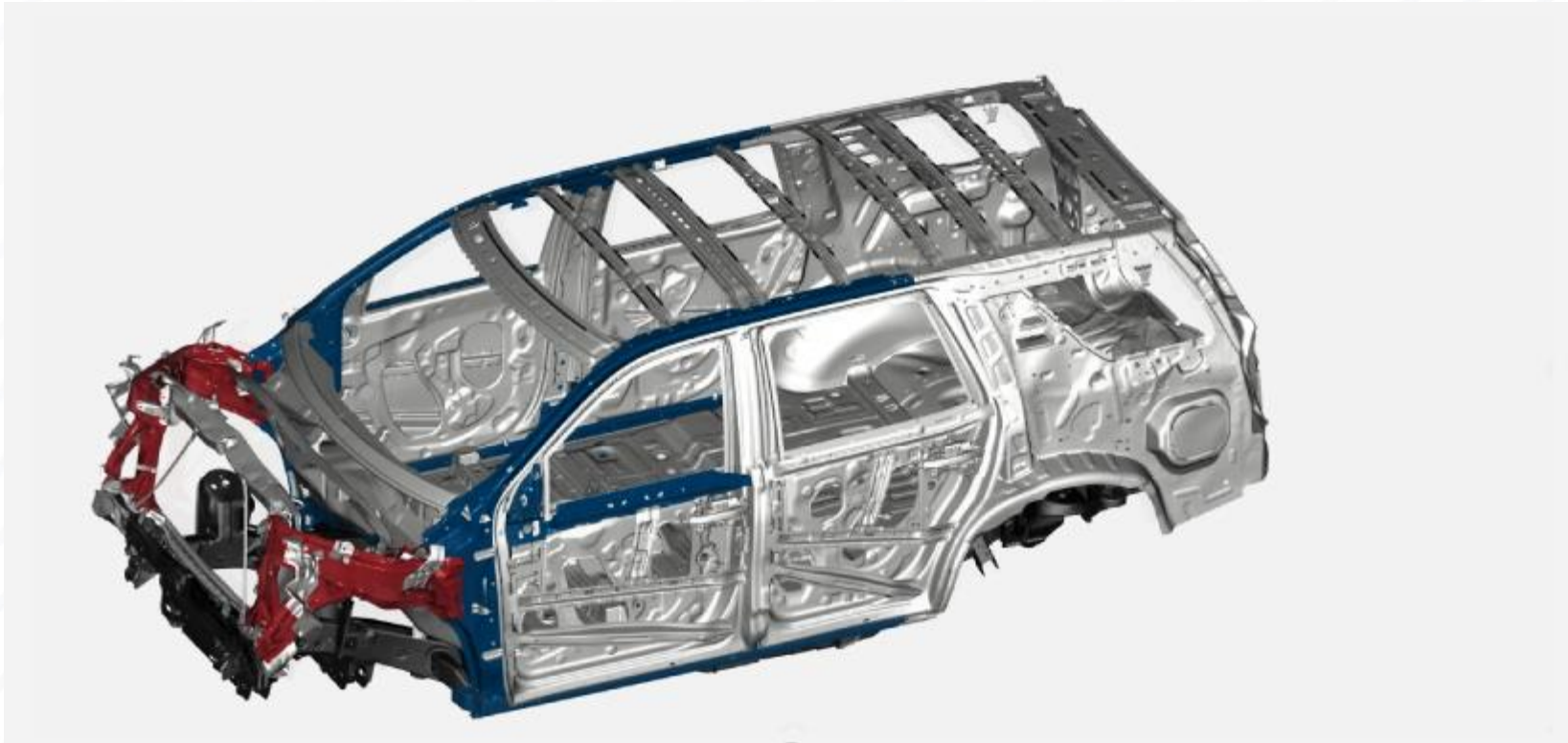

Upper Load Path

Impact Load travels from the radiator support, through the upper rail then is distributed by the front body hinger pillar into the green house and the rocker section.

FRONTAL IMPACT BIW LOAD PATHS

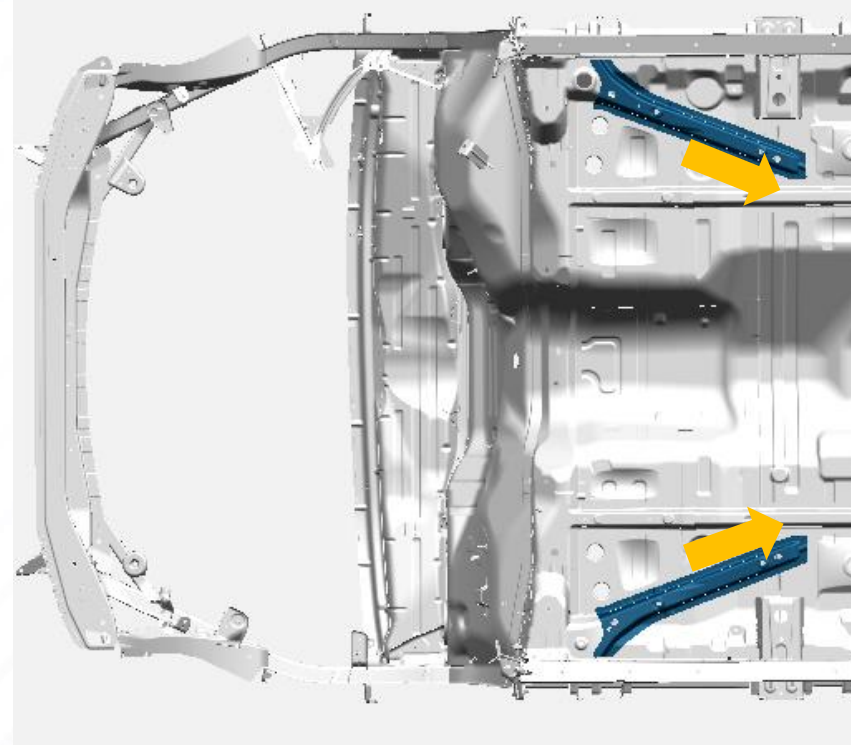
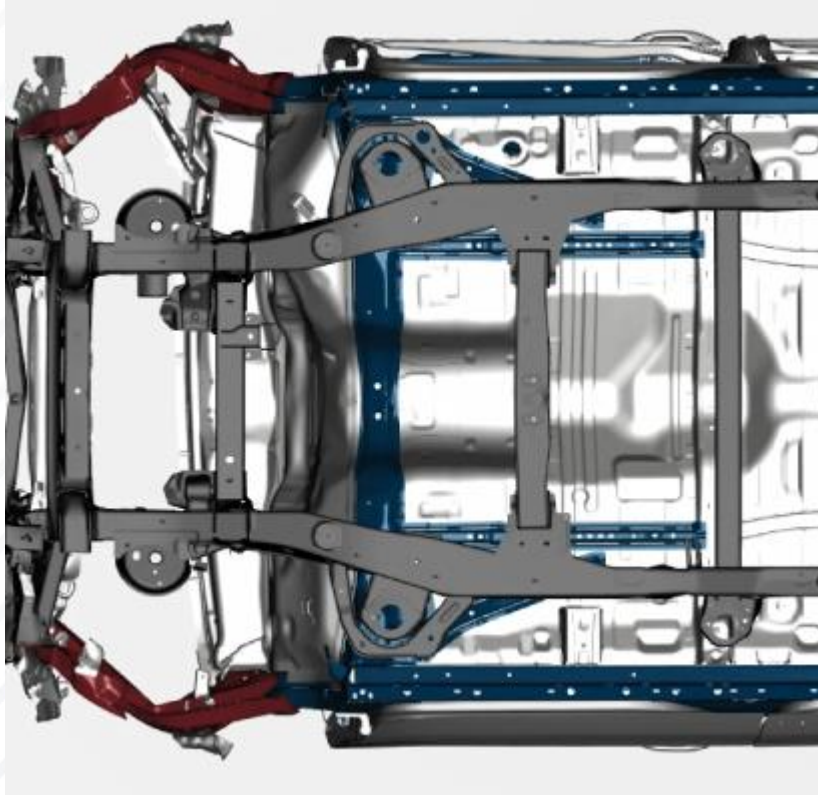

Lower Load Path

The lower load path is shared between the rocker section and the tunnel. The rocker section is stabilized by transitioning off some of the front loads toward the center of the floor structure.

SIDE POLE IMPACT BIW LOAD PATHS

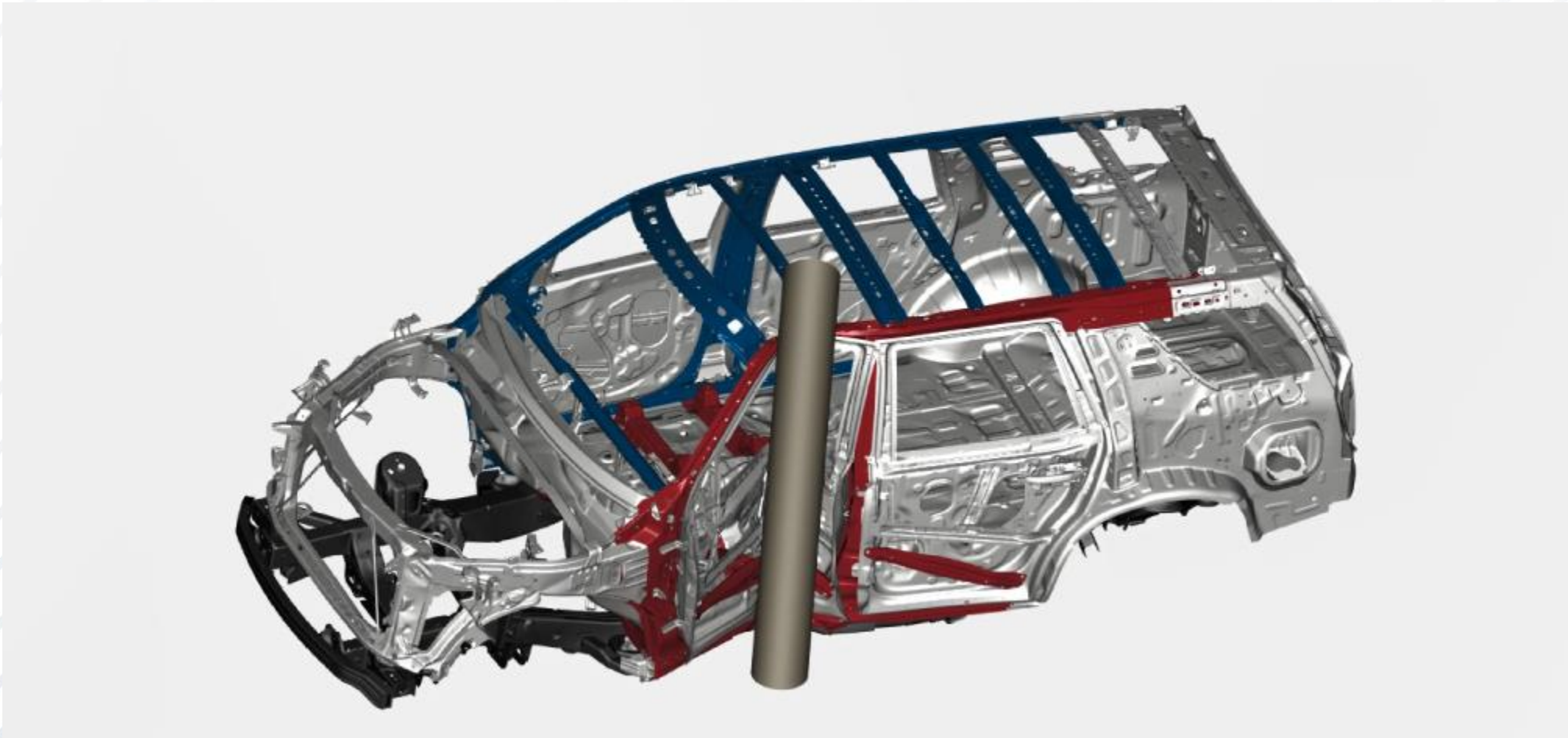

SIDE POLE IMPACT BIW LOAD PATHS

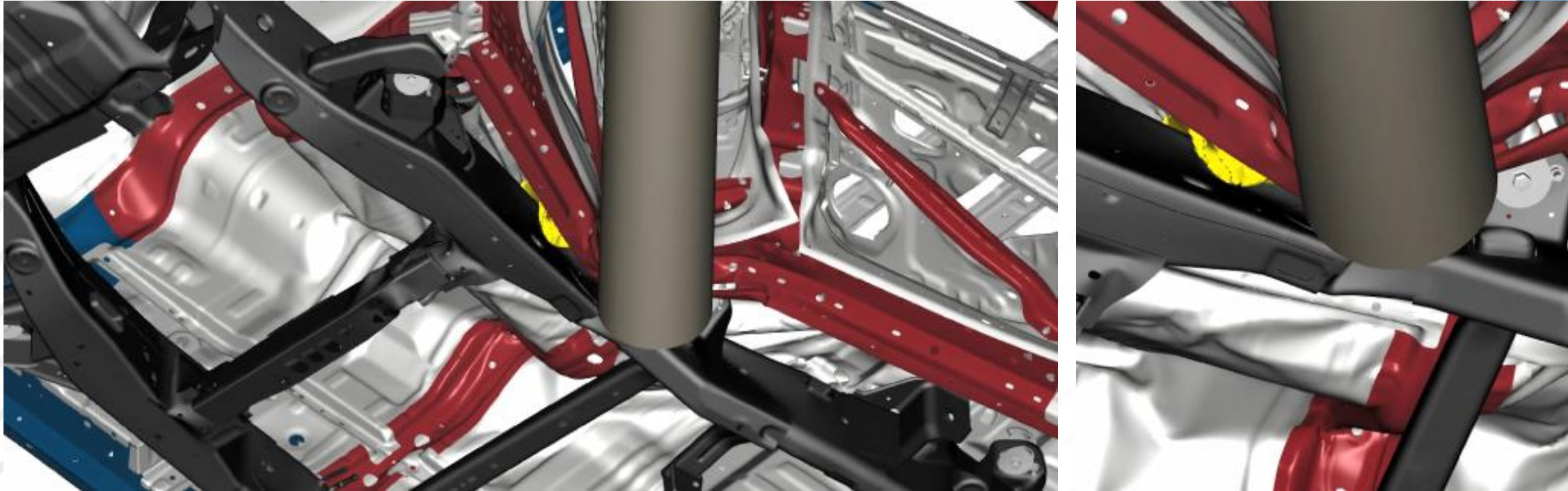

Crush box (yellow) enables engagement between the body in white and frame for efficient load transfer in side impacts.

GM Patent #10392053

Material Strength

Low

High

AHSS

Stainless

UHSS

PHS

Aluminum

ESCALADE CENTER PILLAR CONSTRUCTION



Previous Generation

New Cadillac Escalade

340LA B-Pillar Outer Brace

Composite B-Pillar Outer Brace

PHS B-pillar Outer Reinforcement

PHS B-pillar Outer Reinforcement (Tailor Rolled Blank)



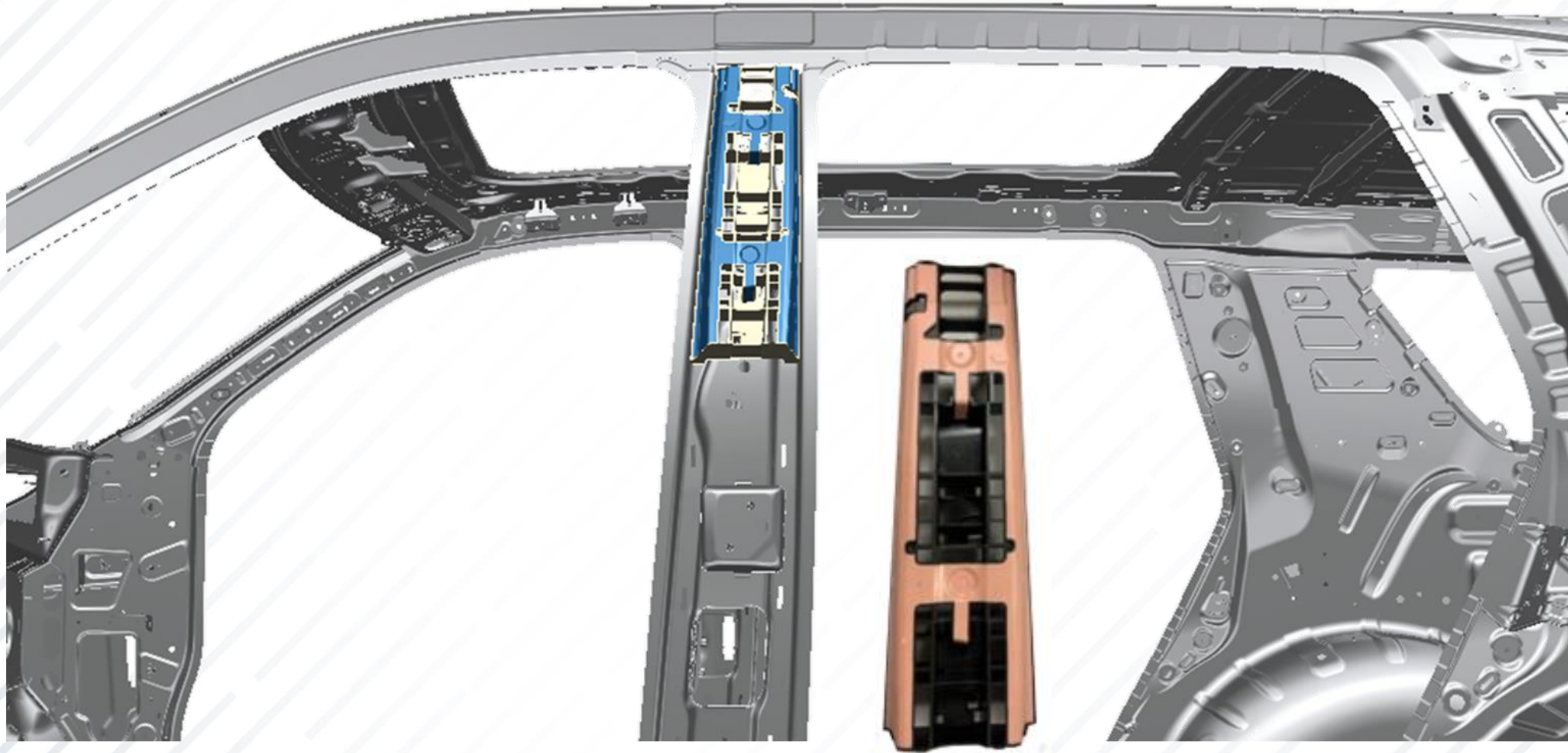

DYNAMIC FUEL
MANAGEMENT



CABIN BOOM



HOW WE SET THE FOUNDATION

- Frame to body interface
 - + All new frame and underbody
 - + Mounts aligned with primary structure
- Improved body stiffness

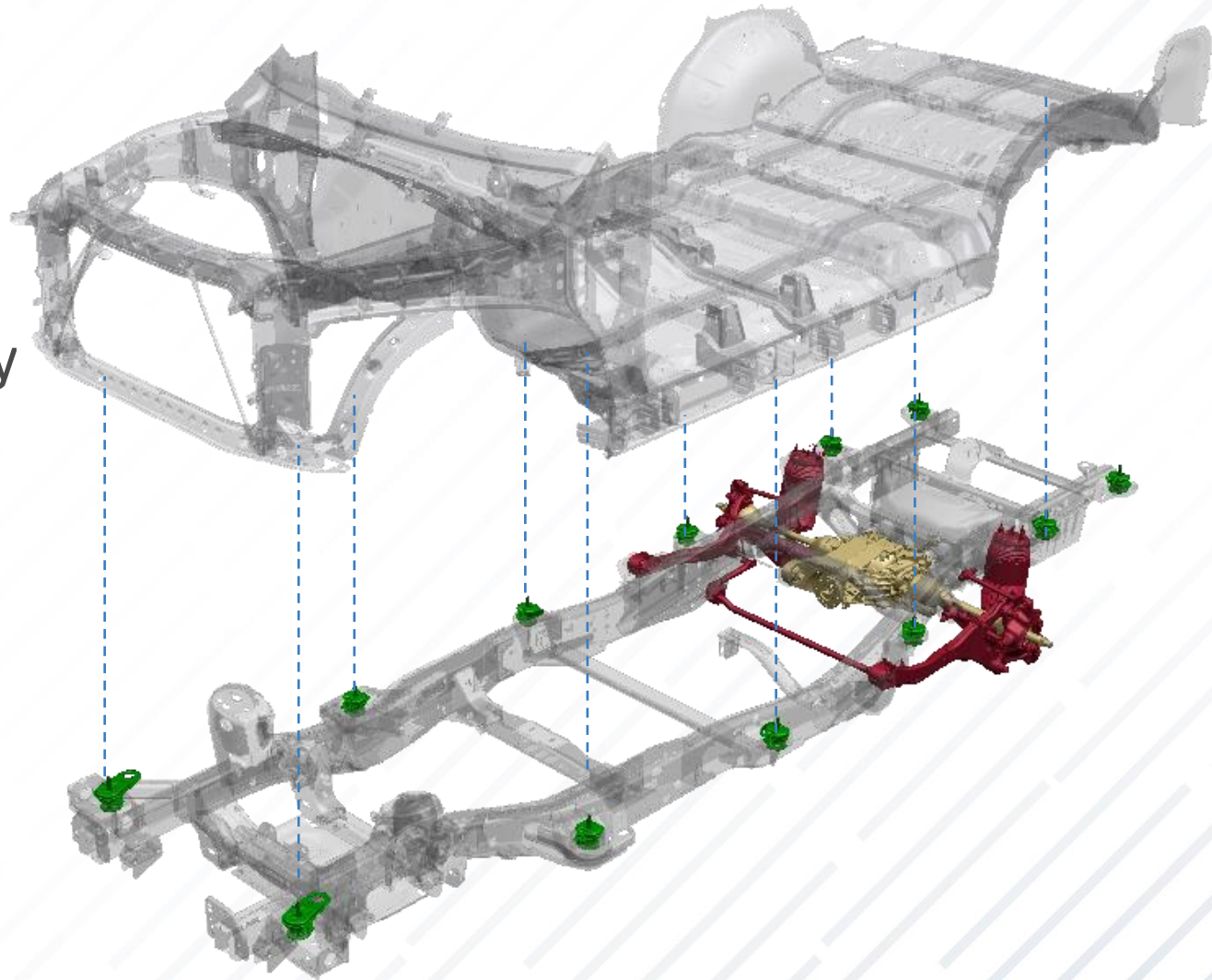

BODY MOUNT INTERFACES

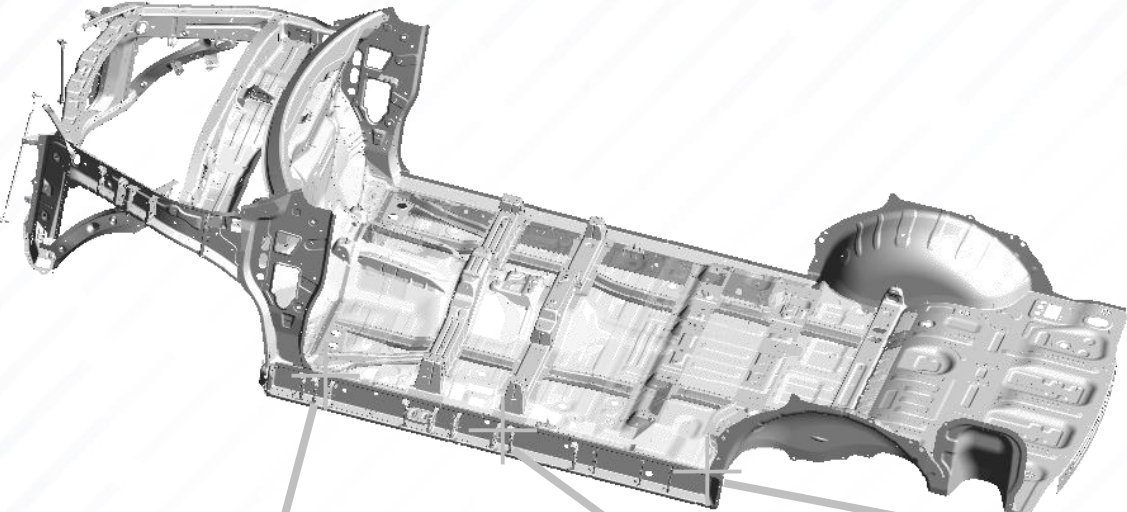

#3 Mount

#1 Mount

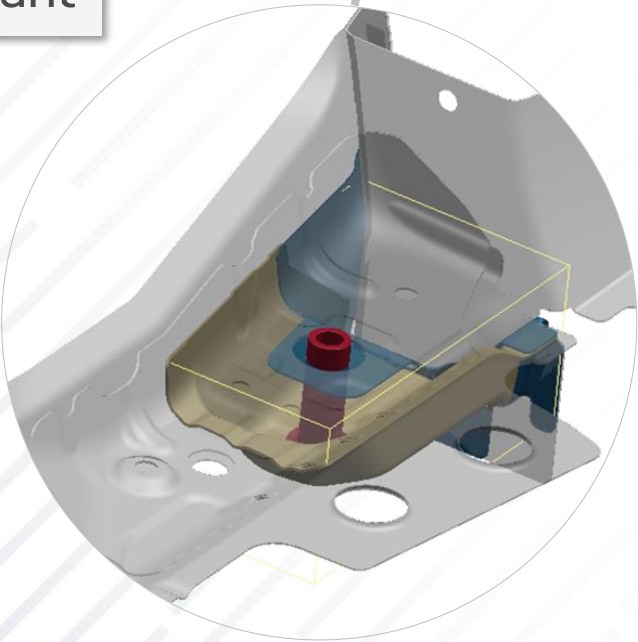

#2 Mount

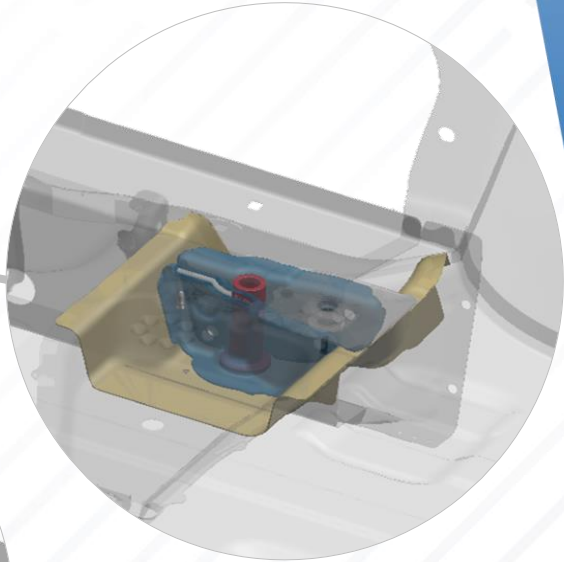
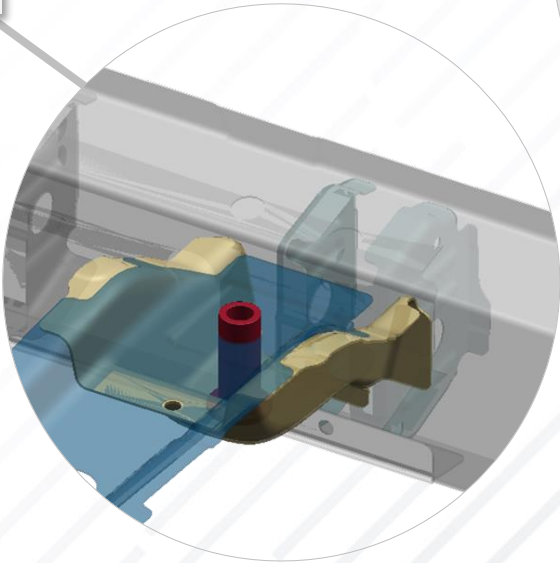

ROAD NOISE

Road Noise, Topology - 20 MPH

- BASELINE
- BASELINE + TOPOLOGY LOAD PATH IMPROVEMENTS

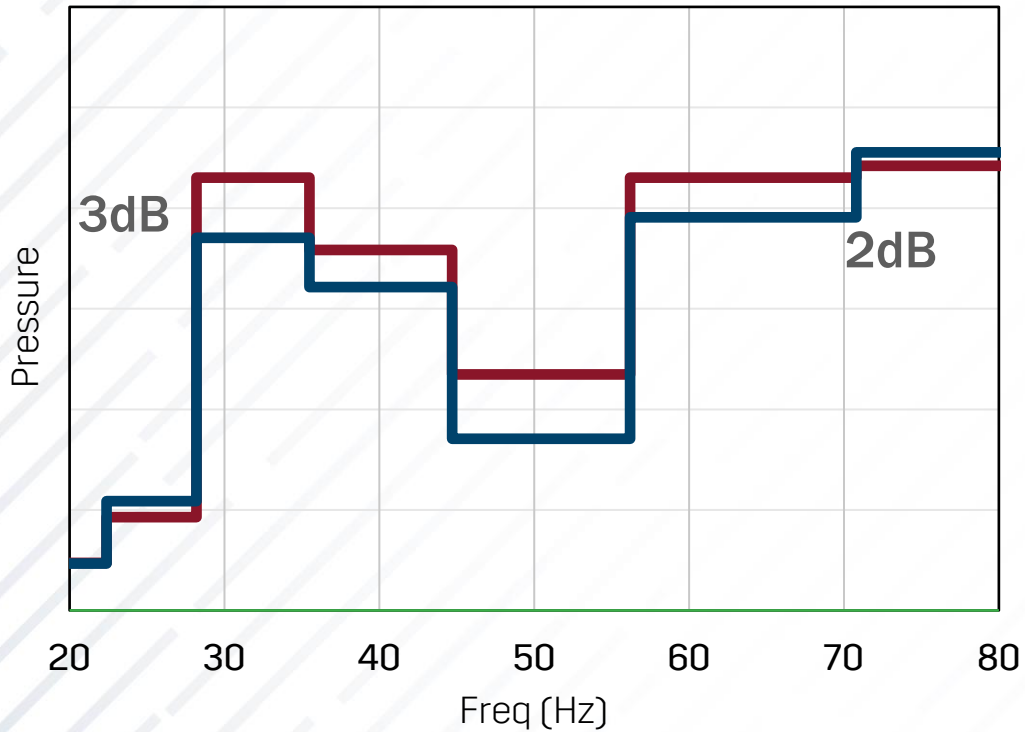

Road Noise, Soft Mounts - 20 MPH

- BASELINE
- BASELINE + TOPOLOGY LOAD PATH IMPROVEMENTS

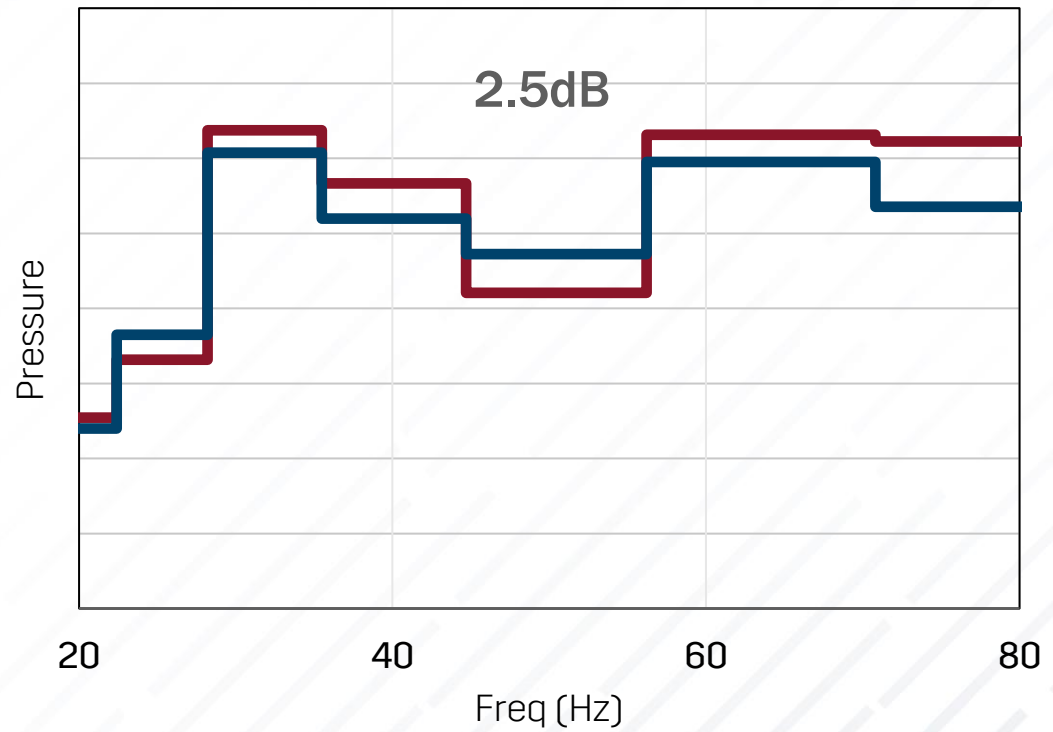

3 dB improvement

ARCHITECTURAL DECISIONS TO SUPPORT NOISE & VIBRATION

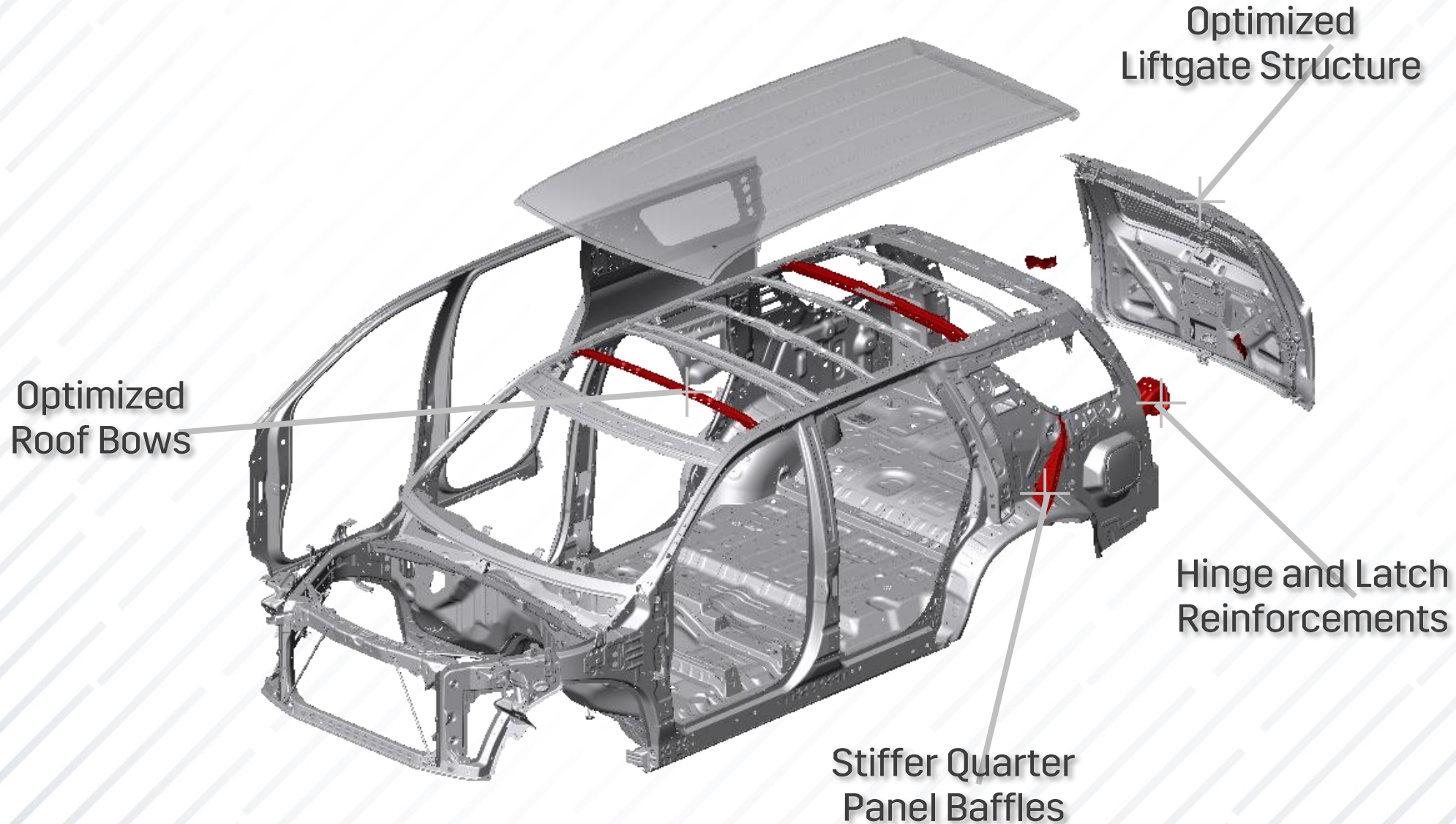

OPTIMIZATION OF PANEL GEOMETRY

Geometry Disrupts
Panel Modes

Reduced Exhaust
Boom Response

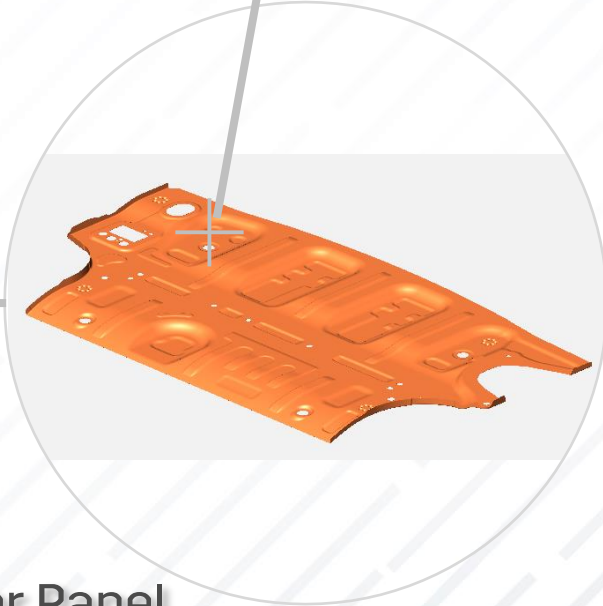
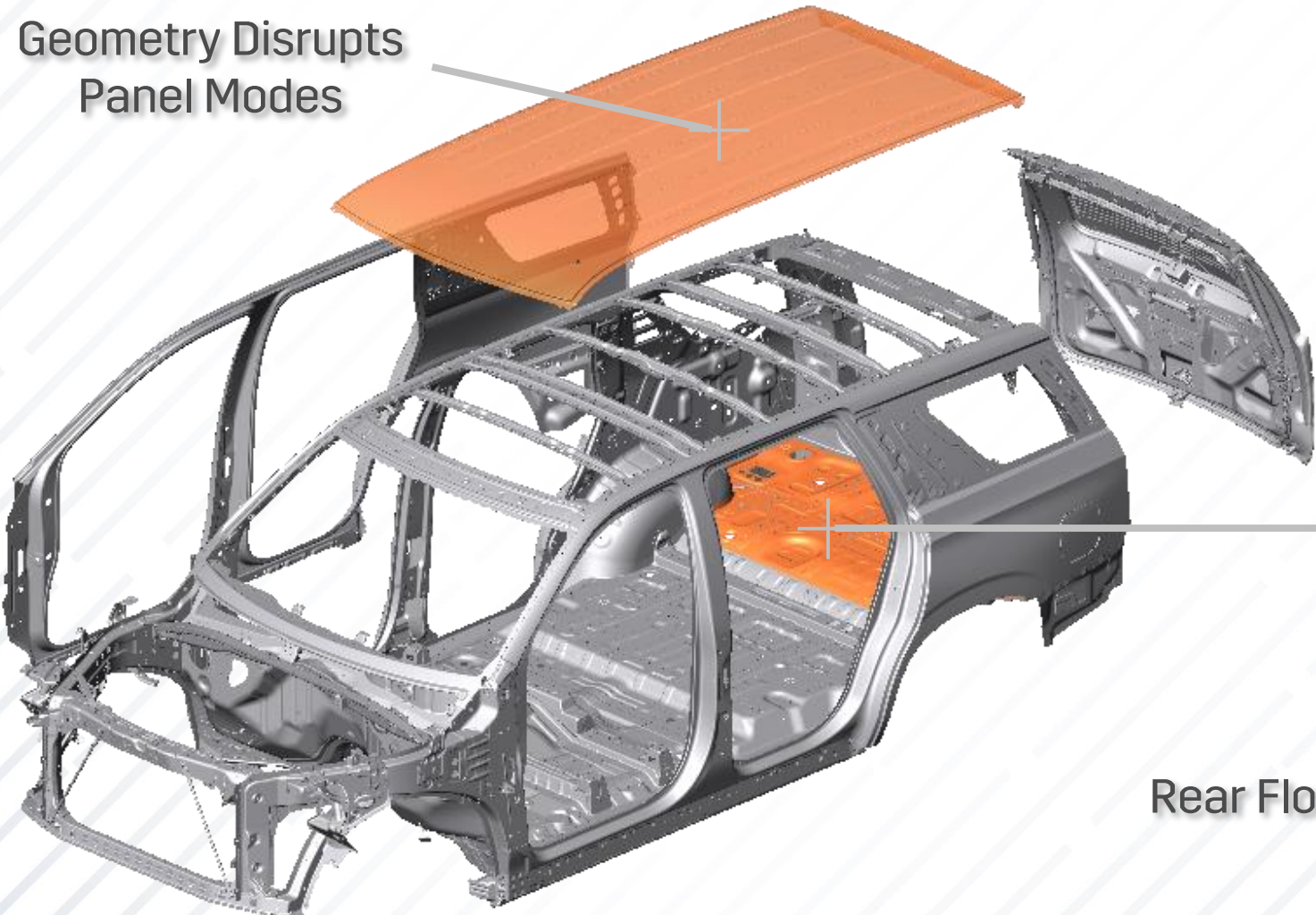

Rear Floor Panel

REDUCTIONS OF CUSTOMER FACING ROAD AND POWERTRAIN LOW FREQUENCY NOISE

Low Speed Coarse Road Noise

— Baseline — Baseline + Boom Package

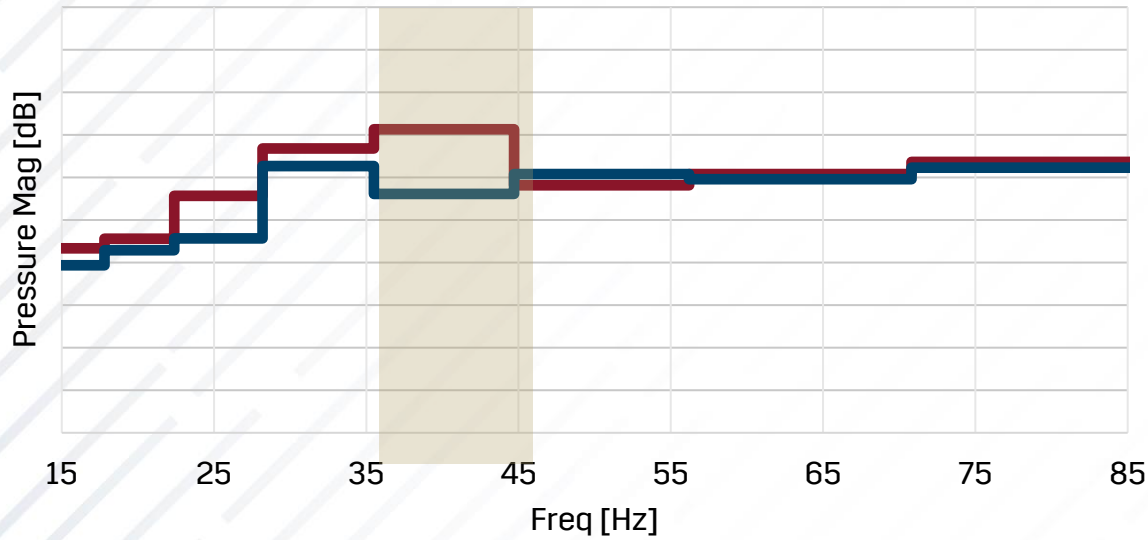

6dB taken out of primary boom range

Powertrain Cruising Noise

— Baseline — Baseline + Boom Package

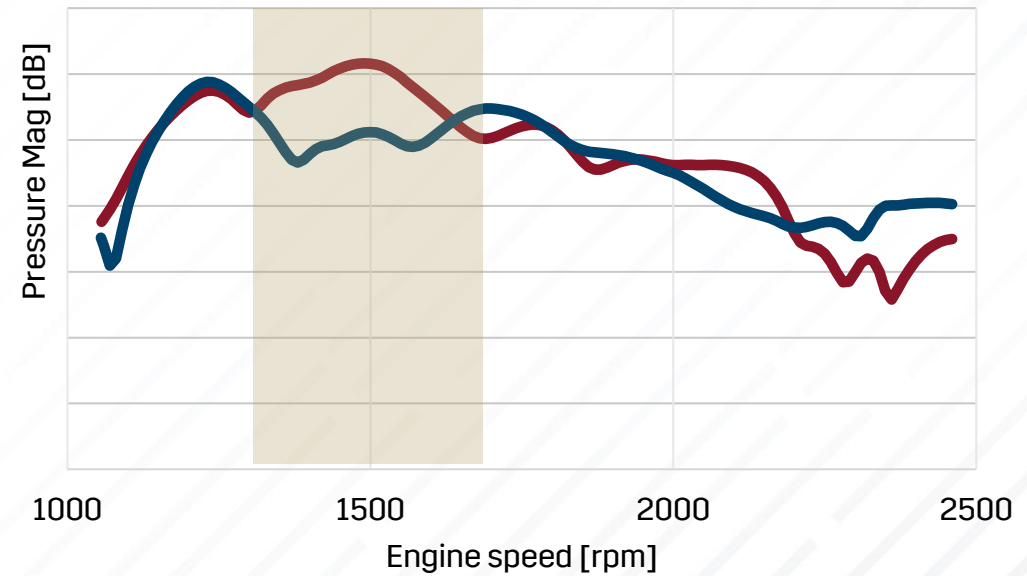

10dB taken out of the low RPM powertrain noise

CREATING THE EXCLUSIVE CADILLAC EXPERIENCE

Creating the exclusive Cadillac experience

- + Improved body response at key occupant to body interfaces
- + Stiffer Body Structure
- + New Shear mount design at Frame to Body Interfaces
- + New Independent Rear Suspension

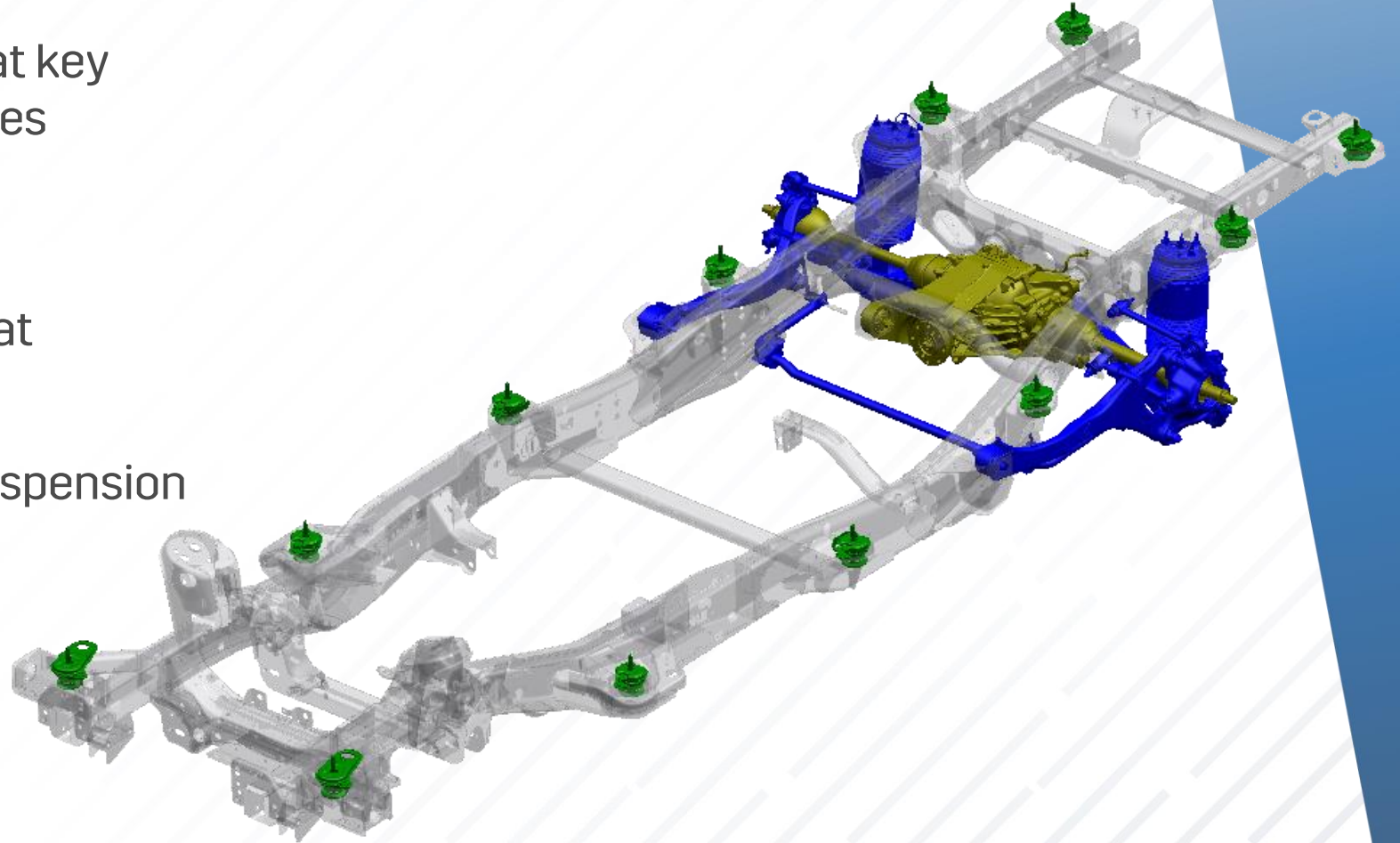

GLOBAL STIFFNESS IMPROVEMENTS

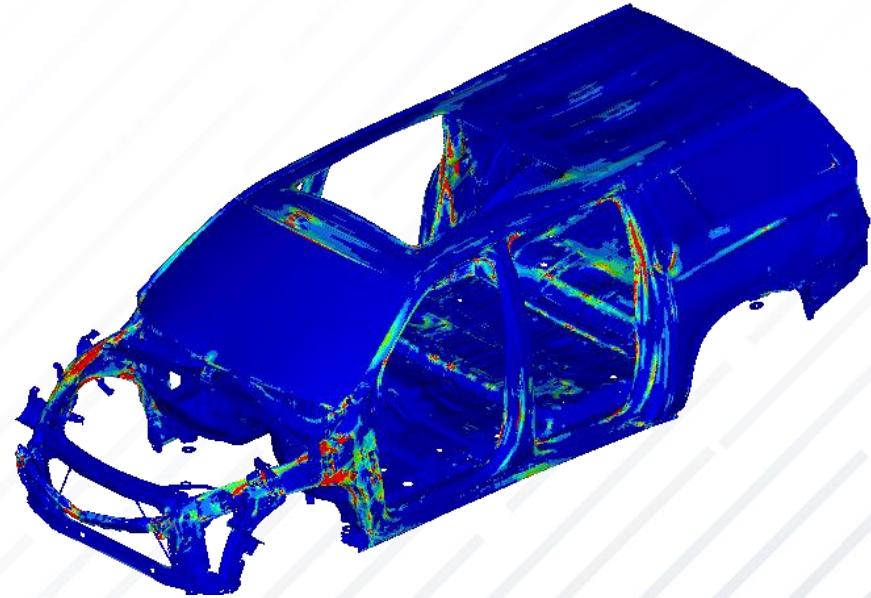
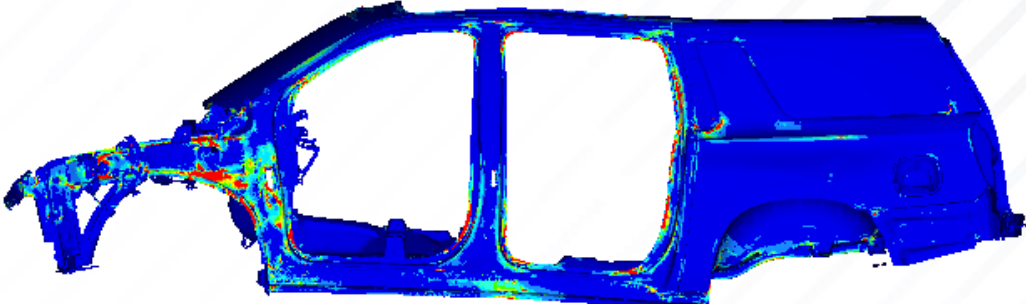
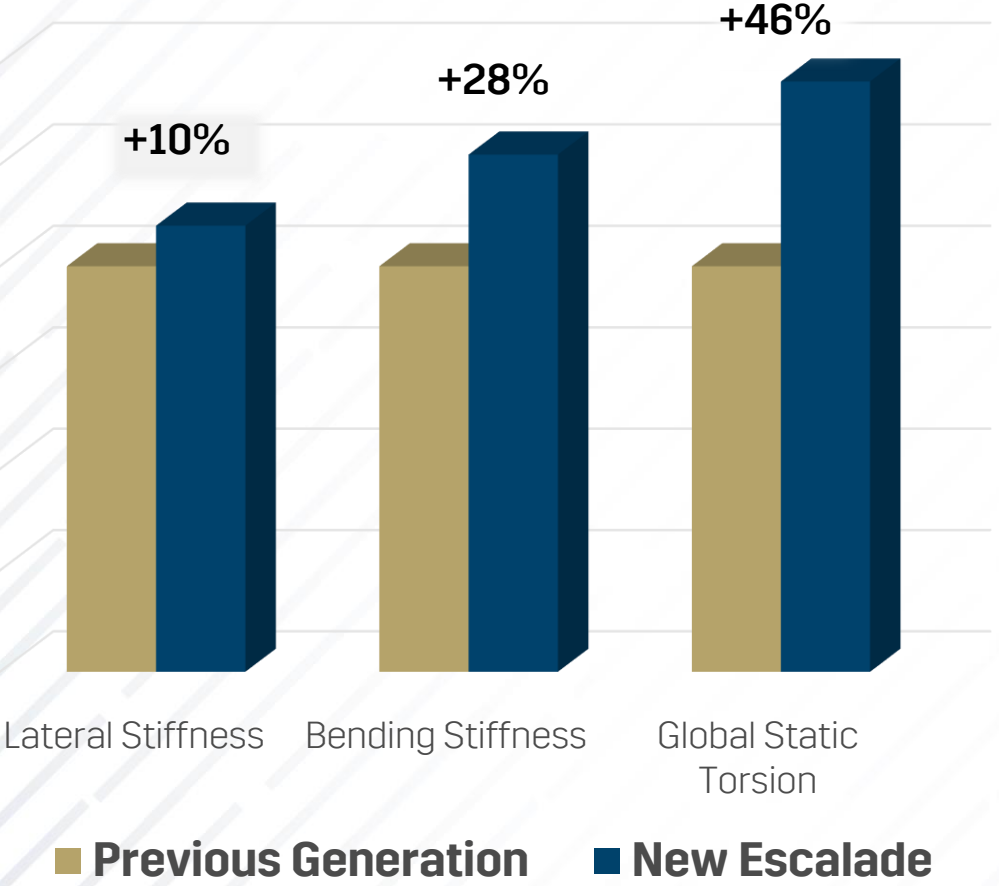

MOUNT STIFFNESS AT BODY

All Body interface stiffness increased by 30-100%

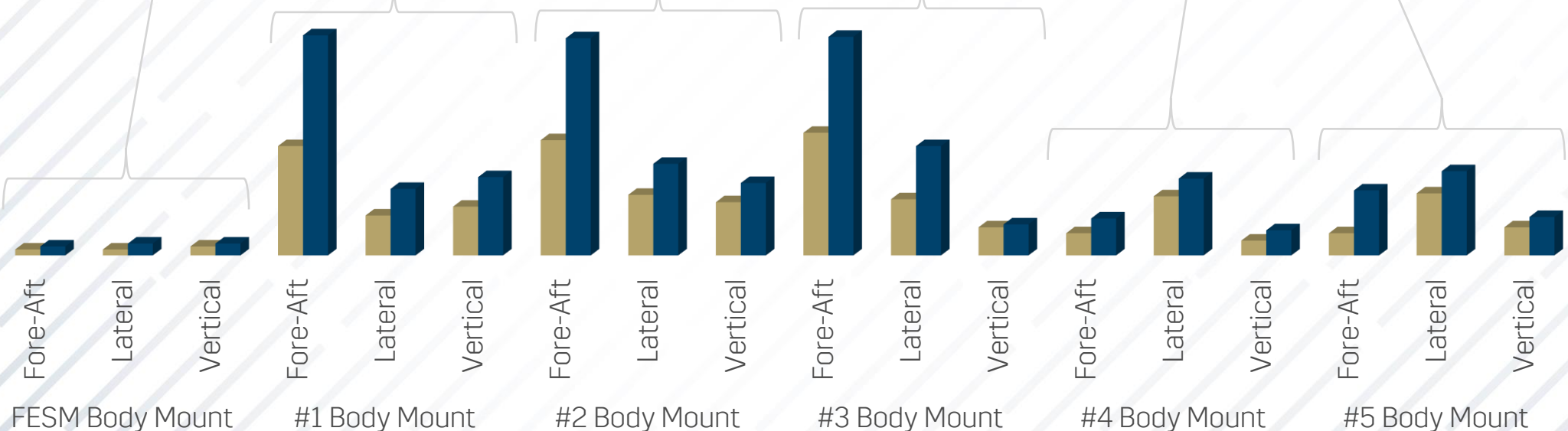
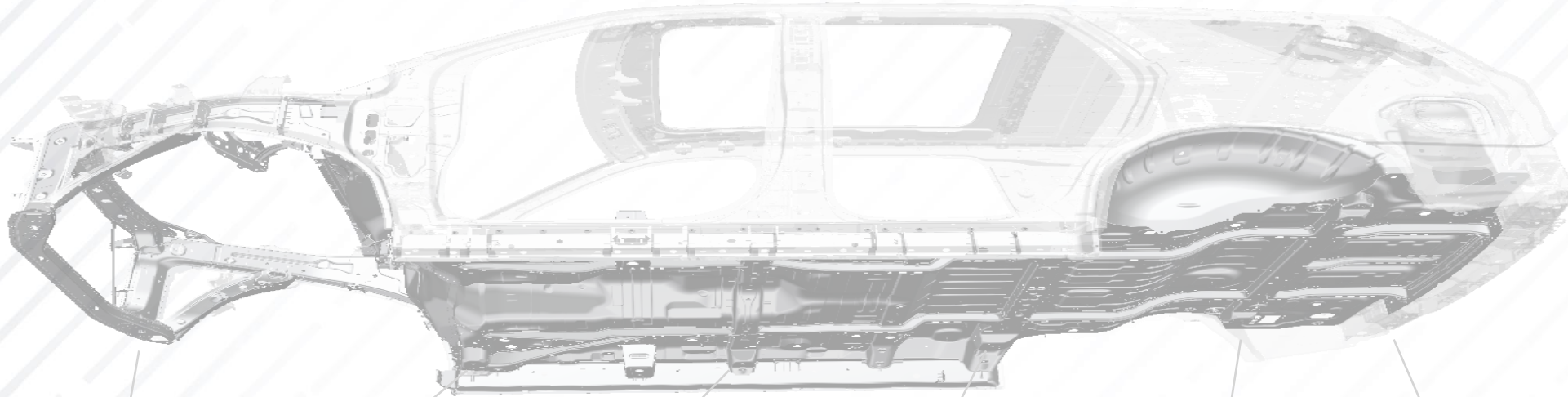

■ Previous Generation ■ New Escalade

DRIVER REAR INBOARD SEAT TRACK RESPONSE

SPALLED CONCRETE @ 45 MPH

- Previous Generation
- - - New Cadillac Escalade

Fore / Aft Response

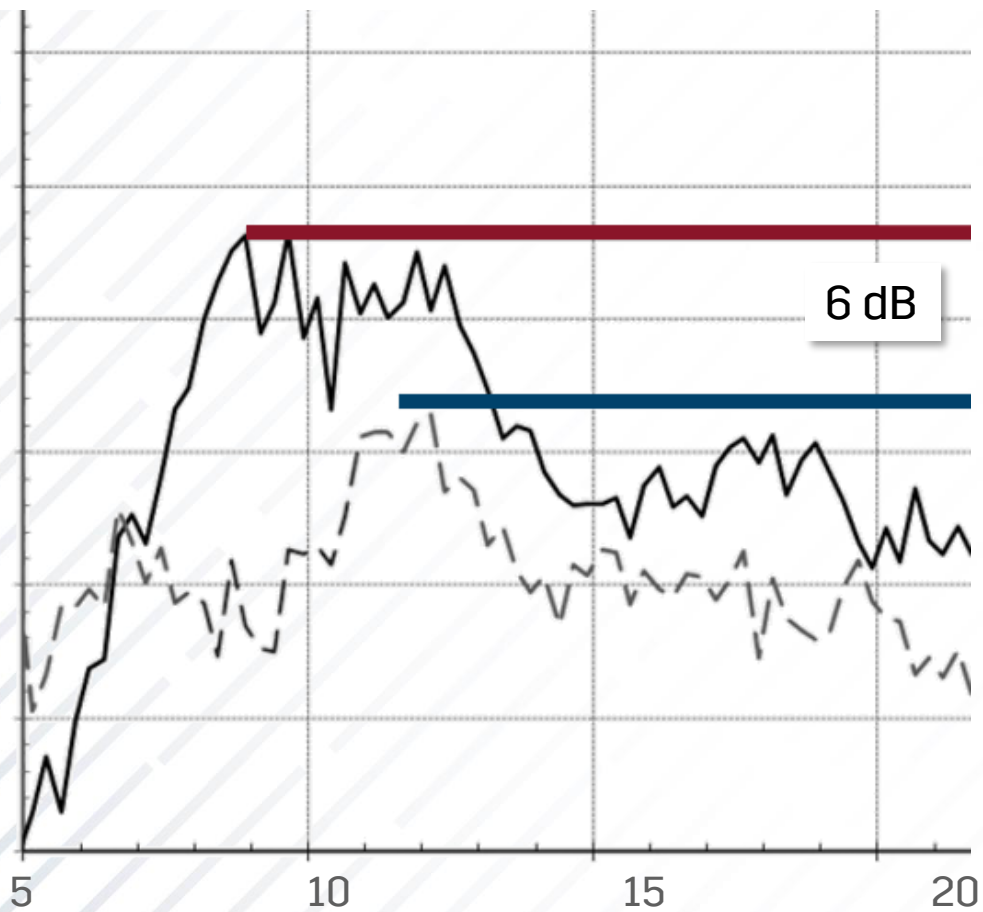

Lateral Response

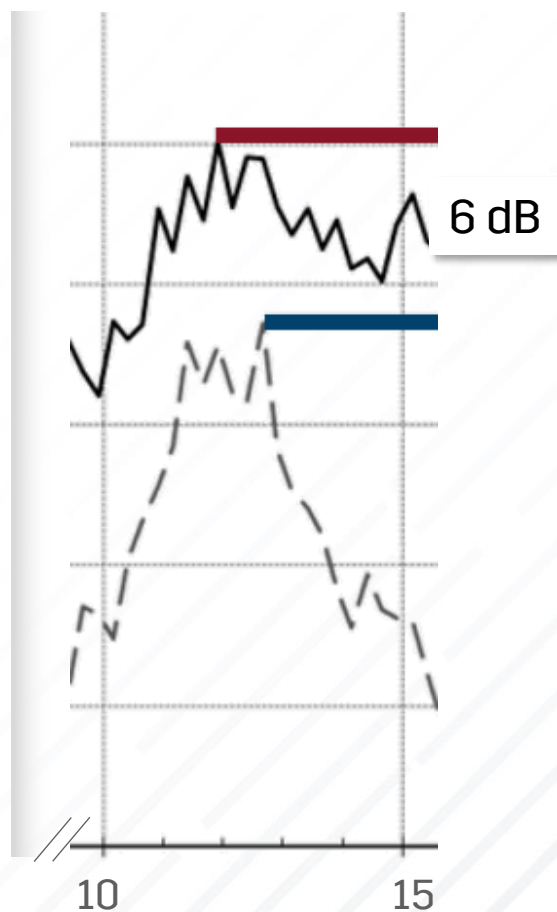

Vertical Response

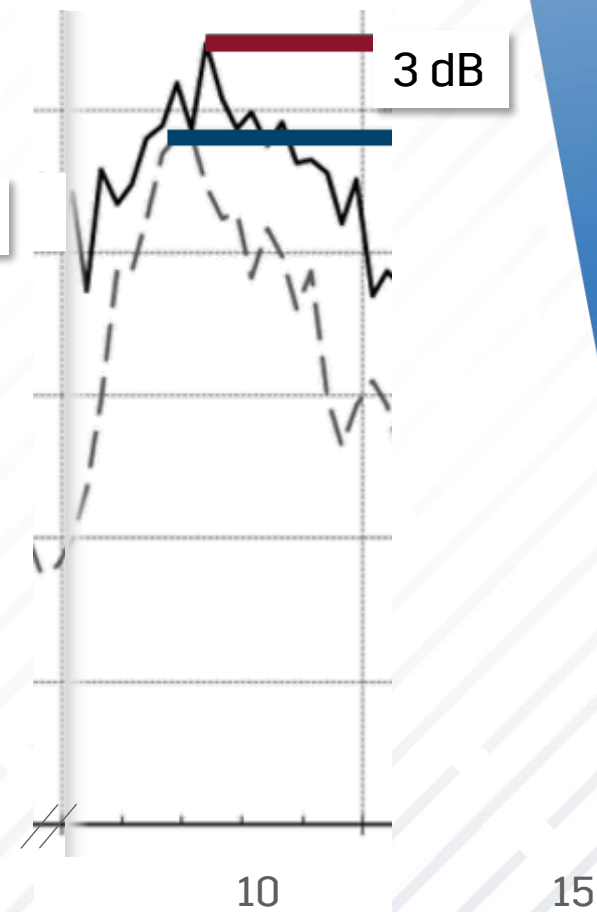

Frequency [Hz]

GREAT DESIGNS IN
STEEL

THE ALL NEW 2021 ESCALADE



Cadillac