

G r e a t D e s i g n s i n

STEEL



2019 Acura RDX World's First Inner & Outer Door Ring System

Joe Riggsby
Honda R&D Americas, Inc.

Honda Global Presence & US Operations

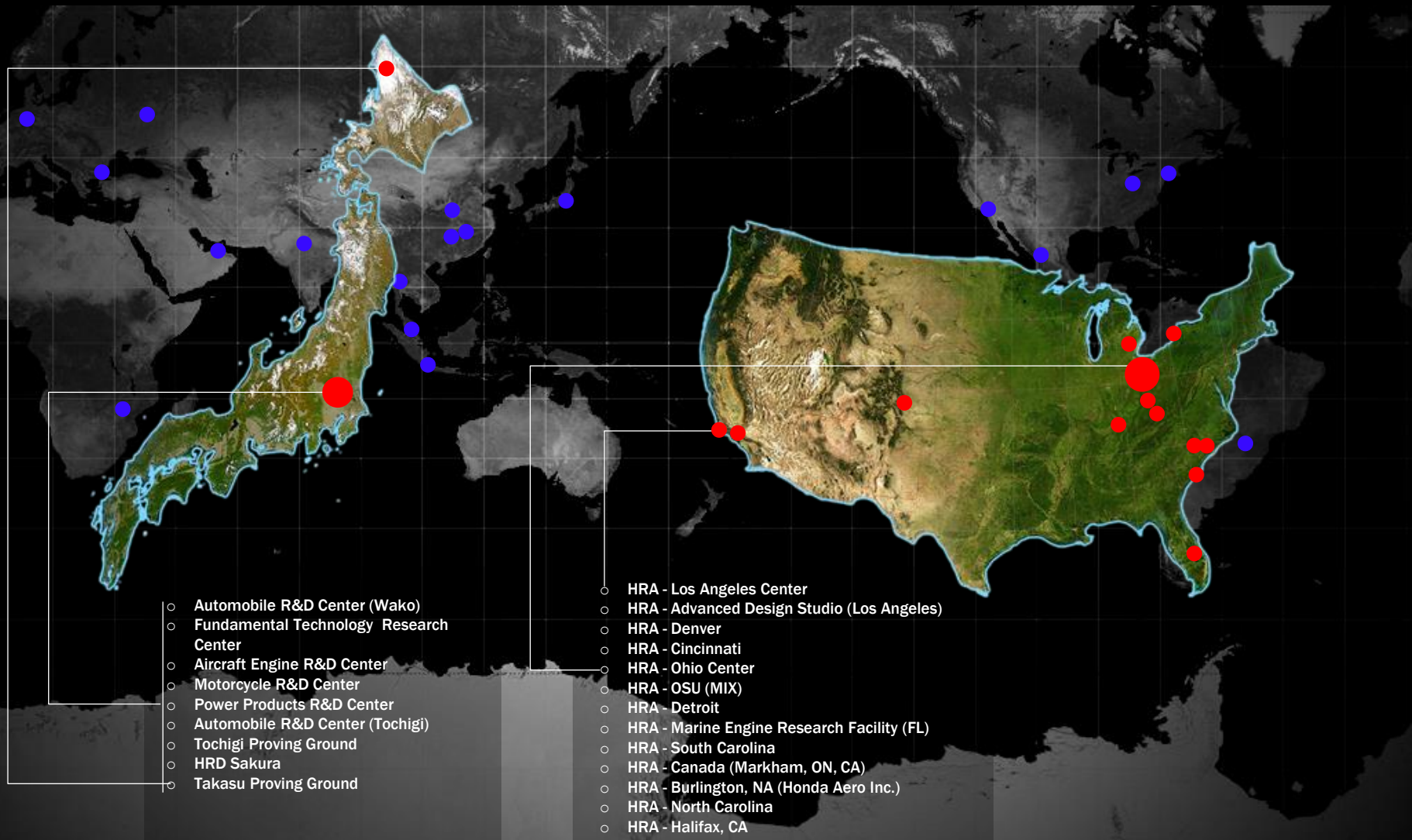

Ohio R&D Center



- Location: Raymond, Ohio
- Size of Building: +1.6 million sq. ft.
- Number of Associates: 1,600+
- Began operations in current building: 1993
- Started operations in Ohio: 1984
- HRA began in California: 1975

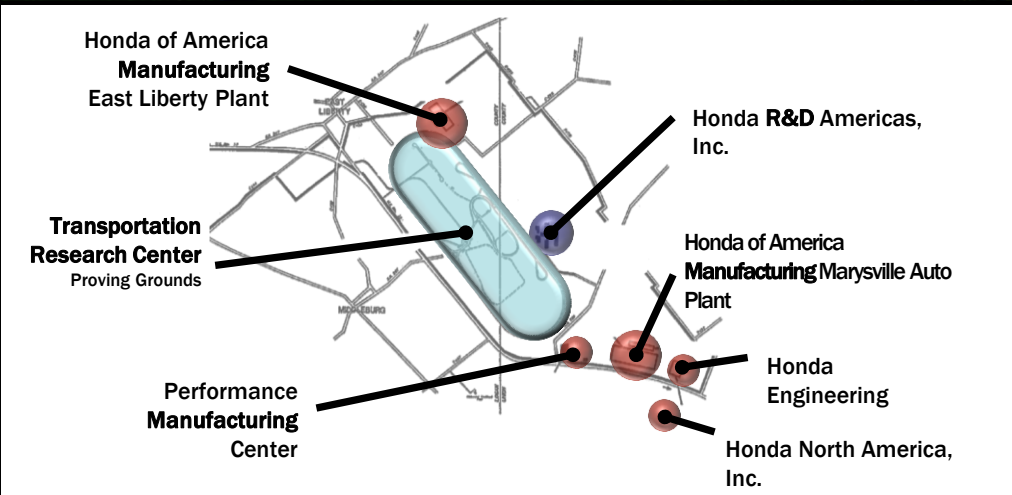

The All-New Acura RDX

The third generation RDX is the quickest, best-handling RDX ever
Top- class cabin and cargo space, and a host of groundbreaking new Acura technologies



- Recent New York auto show debut
- Most extensive overhaul in a decade
- First new styling direction full model change
- Exclusive platform
- VTEC® Turbo engine
- 10-speed transmission
- Acura's True Touchpad Interface

BODY CONCEPT

Body Concept

This body development is all about Super Handling, Acura's pursuit of new levels of dynamic capability, with no sacrifice to safety

Super Handling | Protected

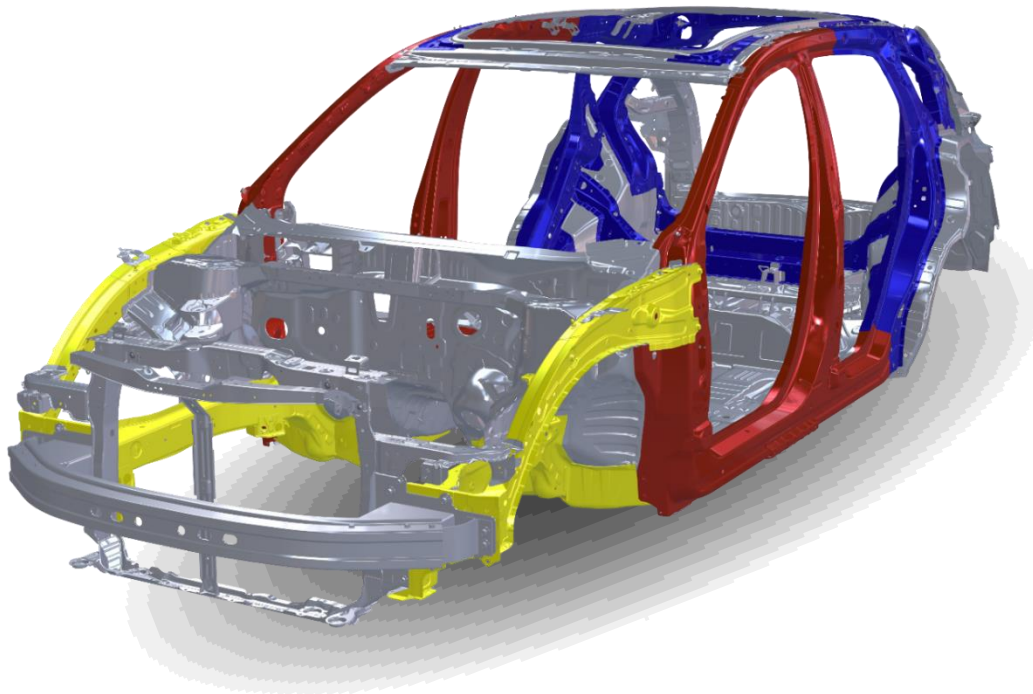

New Rigid load paths for stiffness

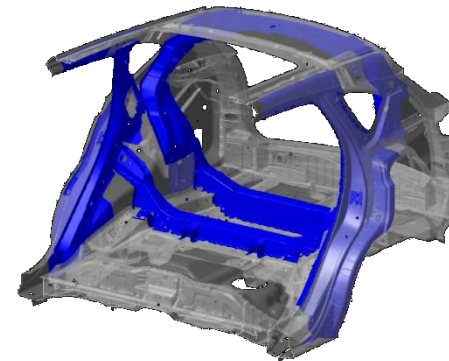

Double Ring Construction for improved stiffness

Outer & Inner Hot Stamp Door Rings (World First)

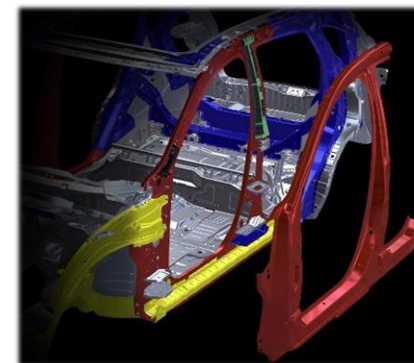

Outer & Inner Door Ring Maintains safety targets with Panoramic Roof Opening

Front Crash, Side Crash, Roll-over Meet or exceed targets

Body Concept

This body development is all about Super Handling, Acura's pursuit of new levels of dynamic capability, with no sacrifice to safety

Super Handling | Protected

New Rigid load paths for stiffness

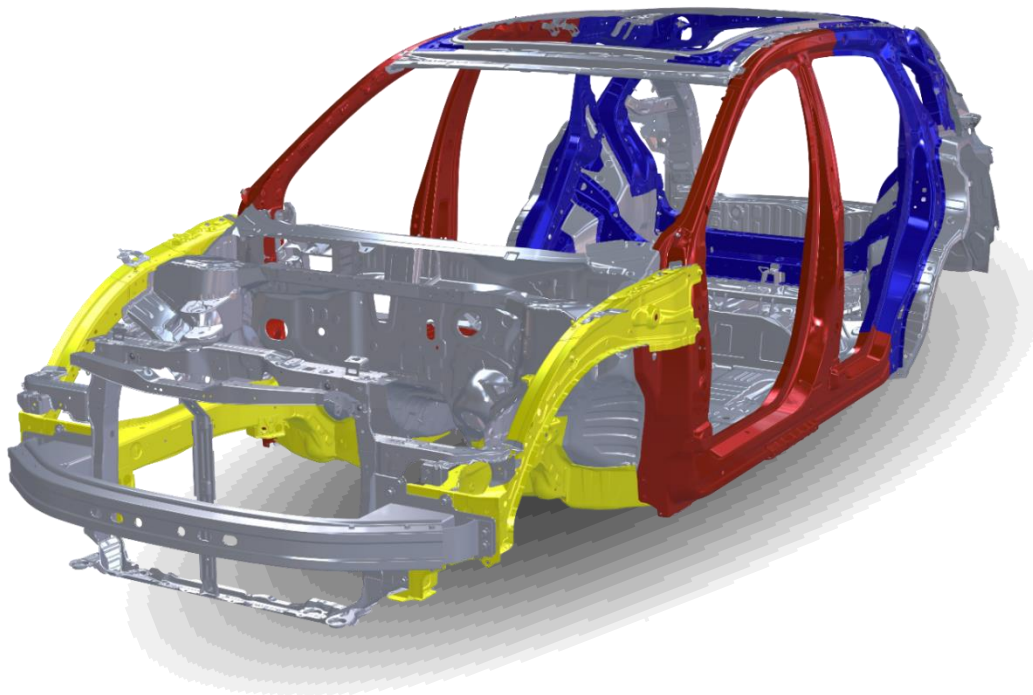

Panoramic Roof Opening

Front Crash, Side Crash, Roll-over Meet or exceed targets

Advanced Material Application

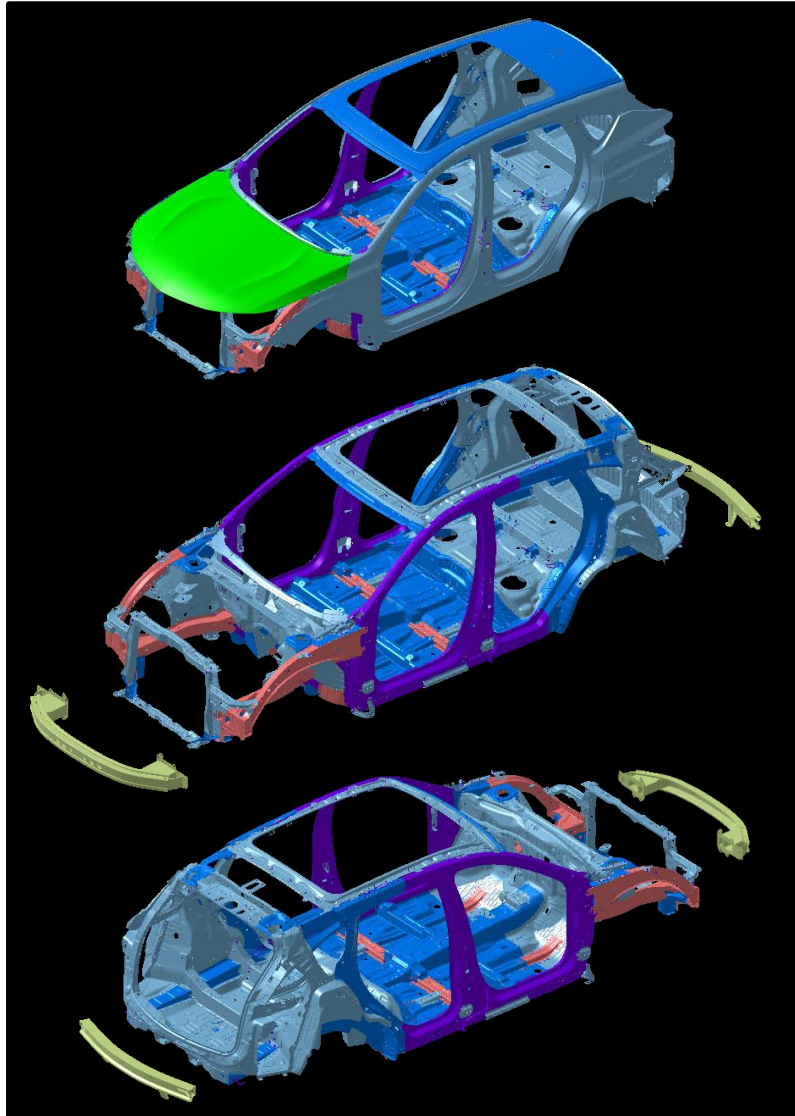

**50% increase in ultra high strength material
Contributes to 19kg weight-down**

- **56%** of whitebody is some form of High Strength Steel
- **26%** of whitebody is Advanced High Strength Steel or higher

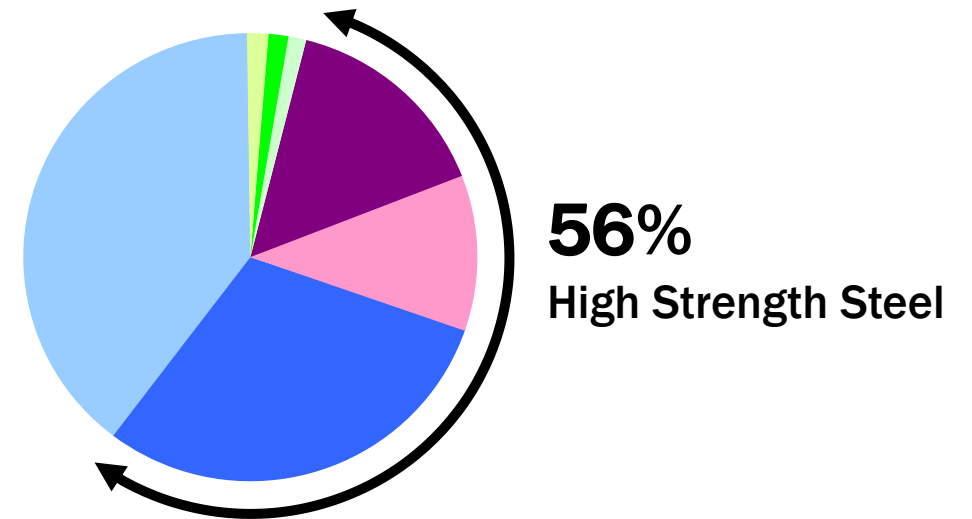

Aluminum Extrusions 6xxx	1.4%	Press Hardened Steel	15.0%
Aluminum Sheet 6xxx	1.4%	Advanced High Strength Steel	11.0%
Aluminum Sheet 5xxx	1.2%	High Strength Steel	30.0%
		Low Strength Steel	40.0%

INNER & OUTER HOT STAMPED DOOR RING SYSTEM

History of Single Ring Concept

Acura has been advancing hot-stamped door ring technology forward for over a decade, working closely with our partners – beginning with 2014 MDX

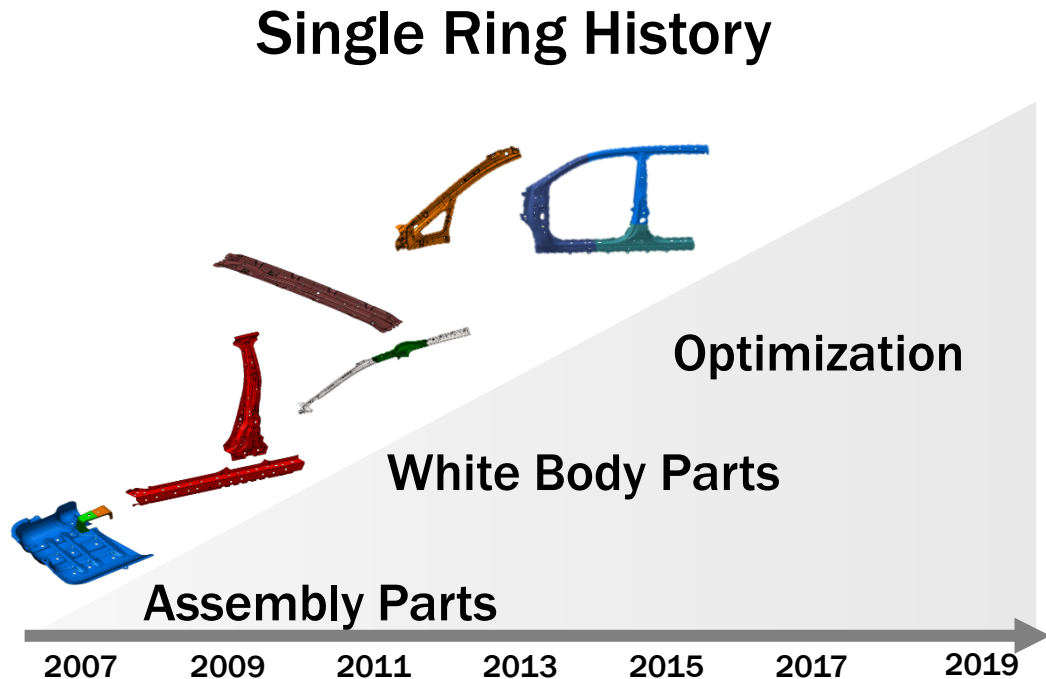

History of Single Ring Concept

The Door ring was a natural progression in the application of hot stamp material on Acura vehicles.

Conventional

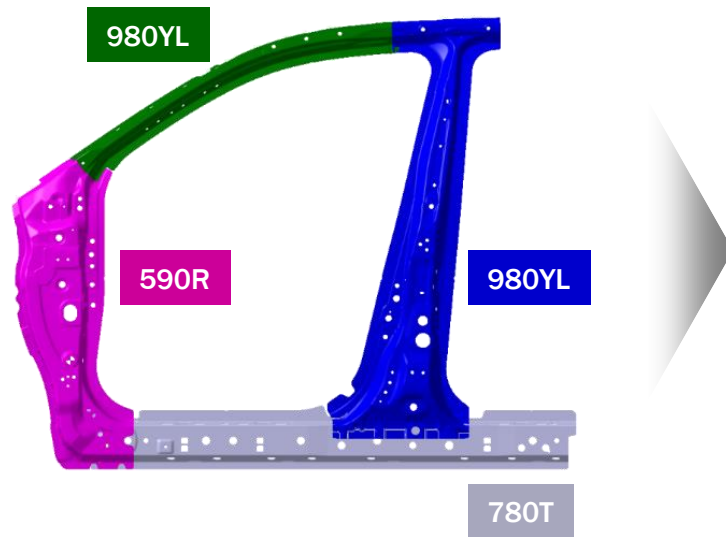

Hot Stamp Concept

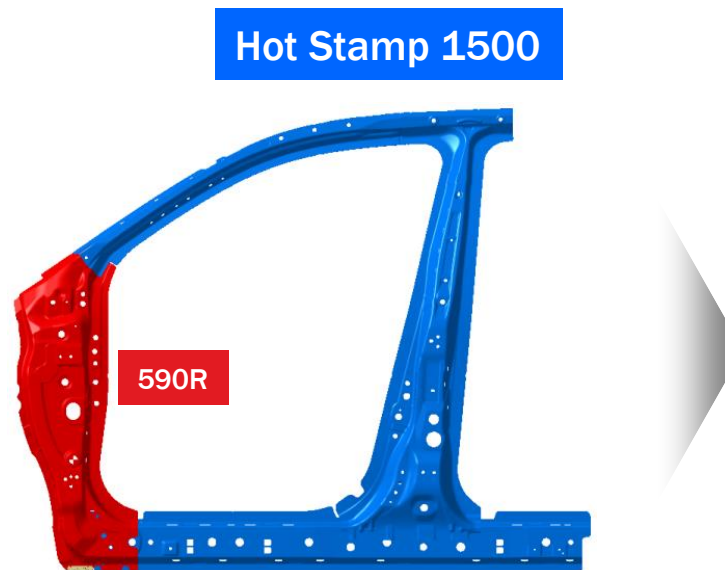

Ring Concept

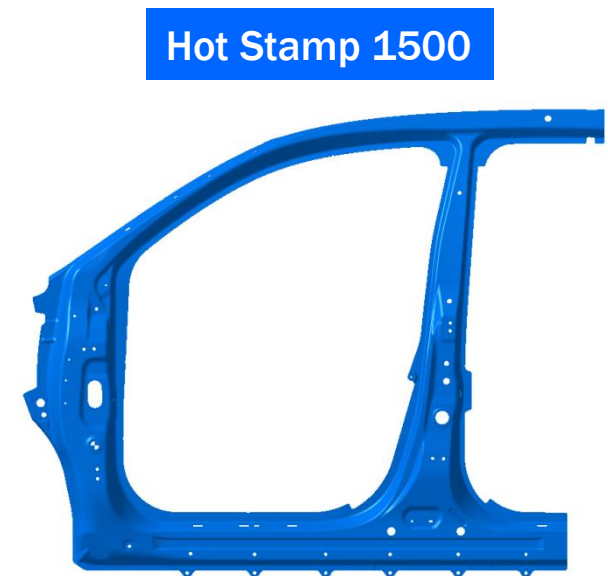

Inner & Outer Door Ring System Concept

In a world first, Acura has created an inner and outer door ring system that takes full advantage of this technology and frees-up tremendous design possibilities

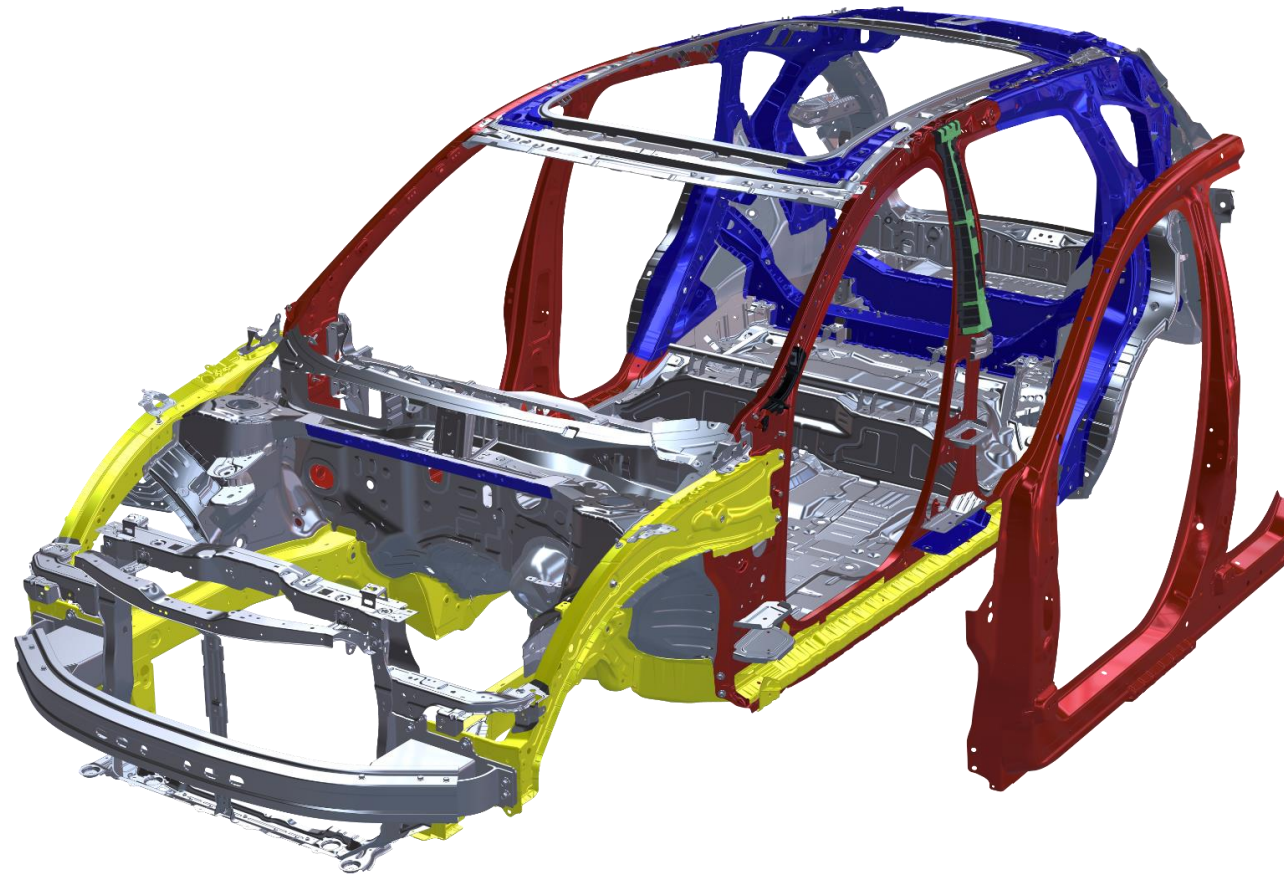

Inner Ring

Inner ring incorporates inner side sill

Enables improved connections to floor structure & roof structure

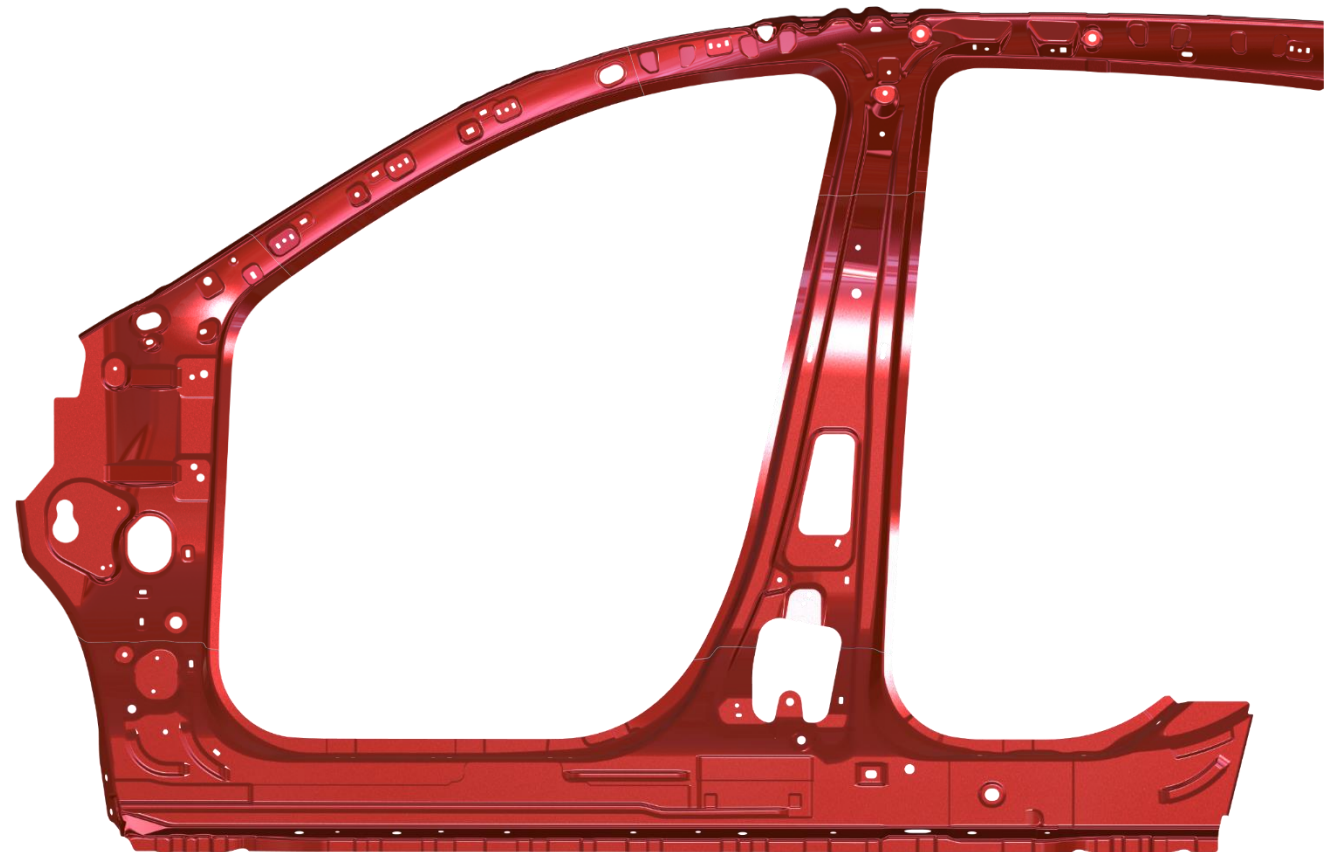
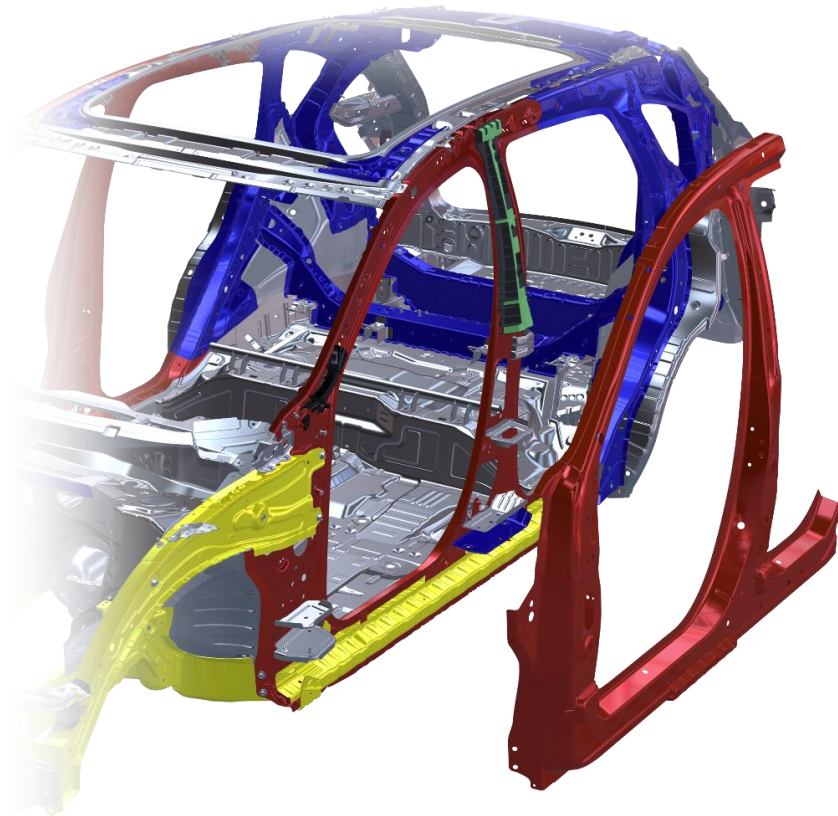

Inner Ring

Tailor welding enables thickness optimization around the ring
Maximizes performance & material utilization

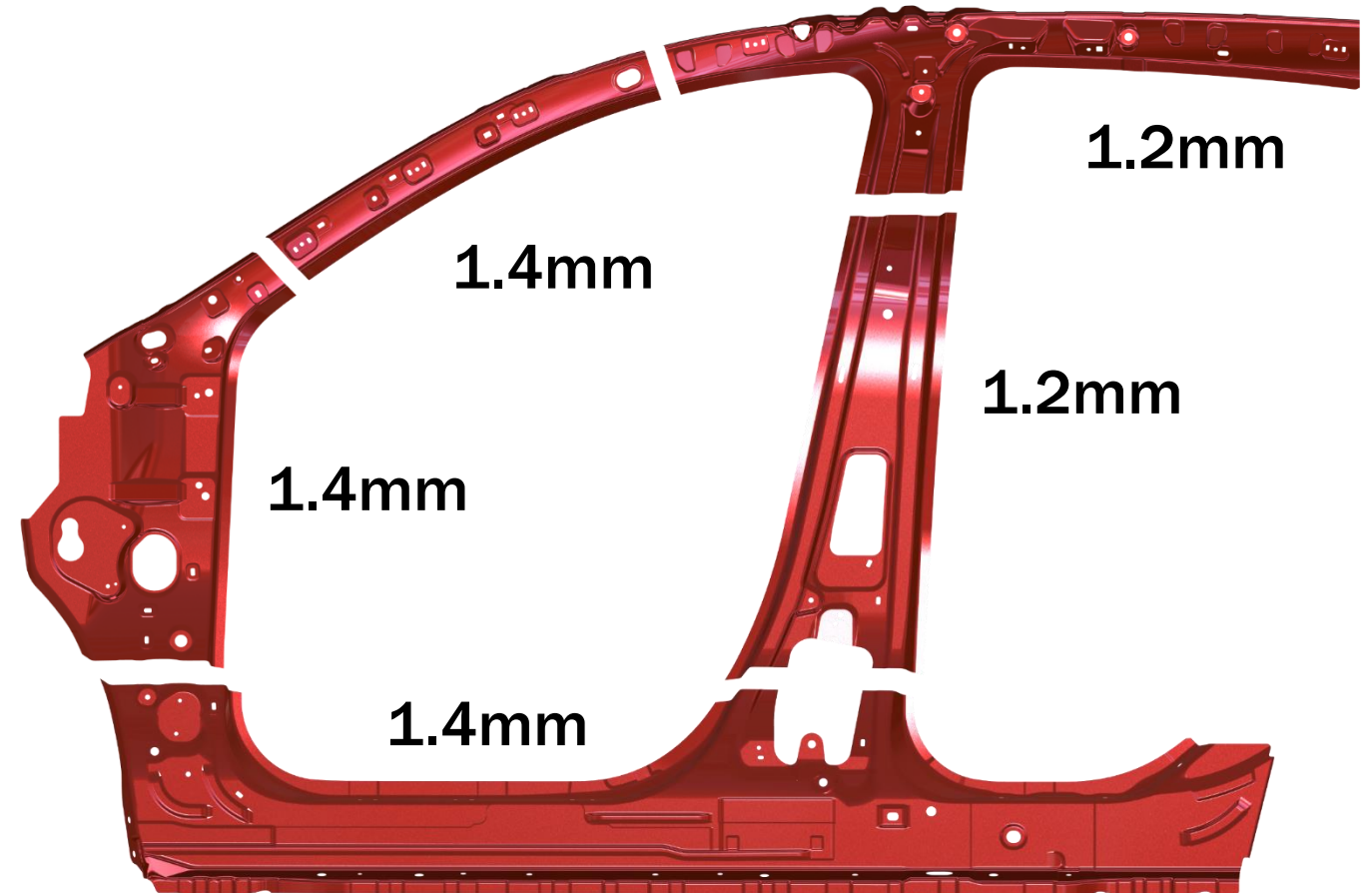
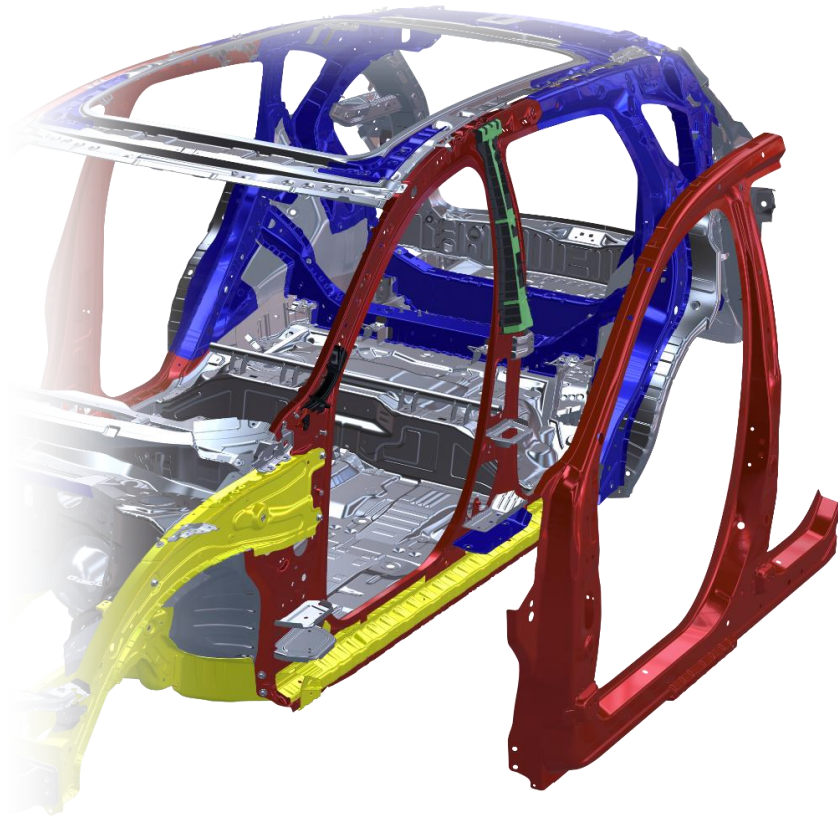

Outer Ring

Outer ring evolution has continued since first application on 2014 Acura MDX

As part of a system, outer ring can be further optimized to balance with inner ring for reduced weight

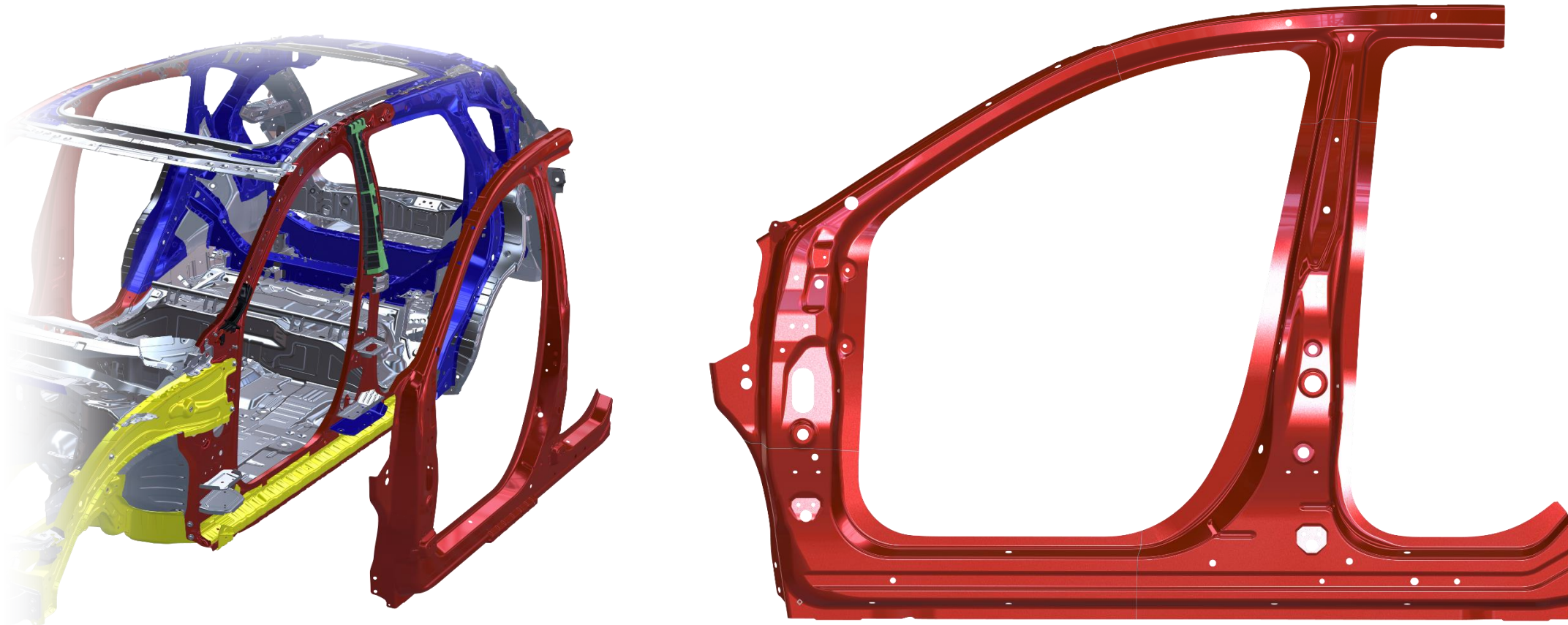

Outer Ring

Tailor welding enables thickness optimization around the ring
Maximizes performance & material utilization

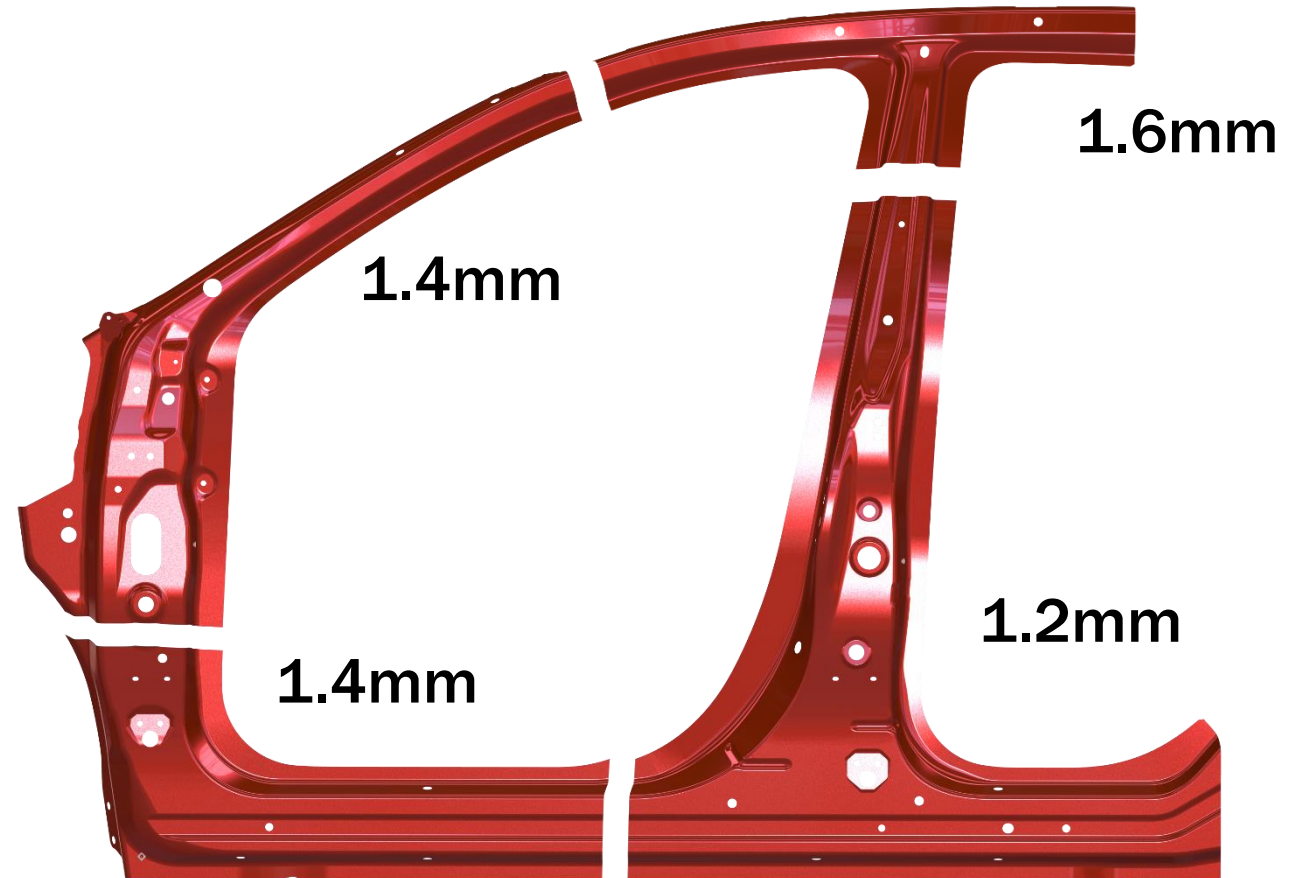
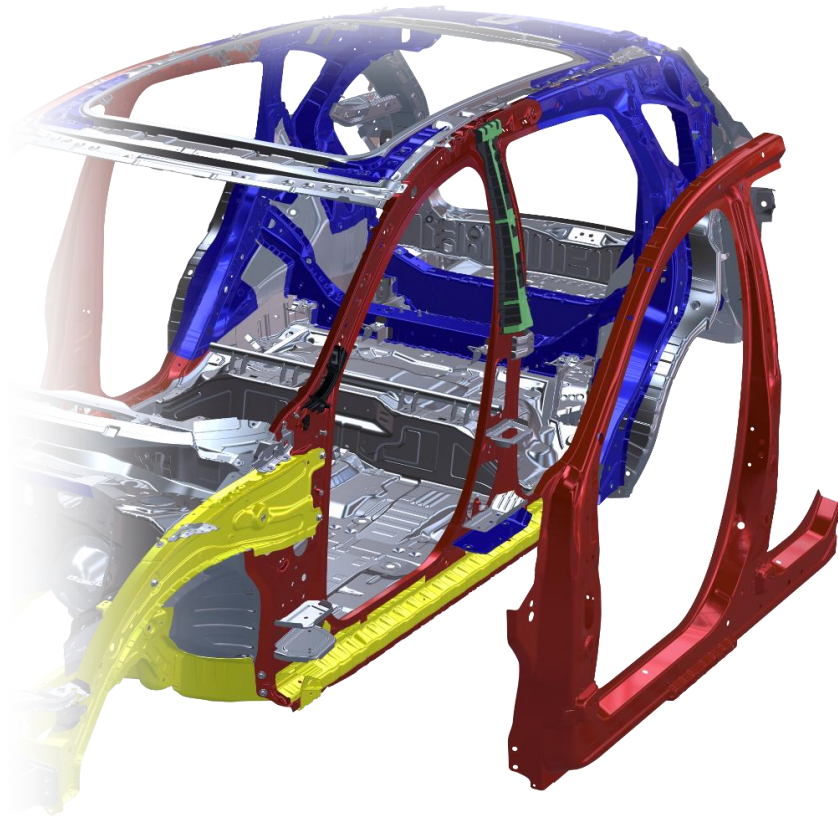

Door Ring System Benefits

- The Welded joints are the weak point in the system and typically need c/m.
- Deleting overlapping material allows for weight down
- Pillar offset from Sill structure, Not efficient load path.
- From MDX & TLX we learned that smooth joints can allow for more efficient design

Conventional

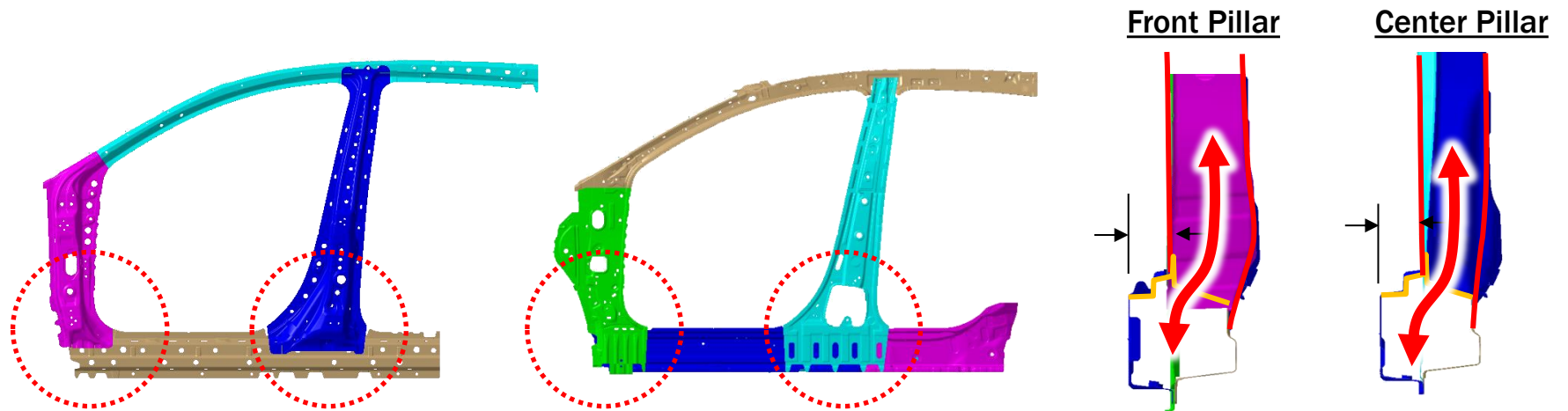

Ring System concept

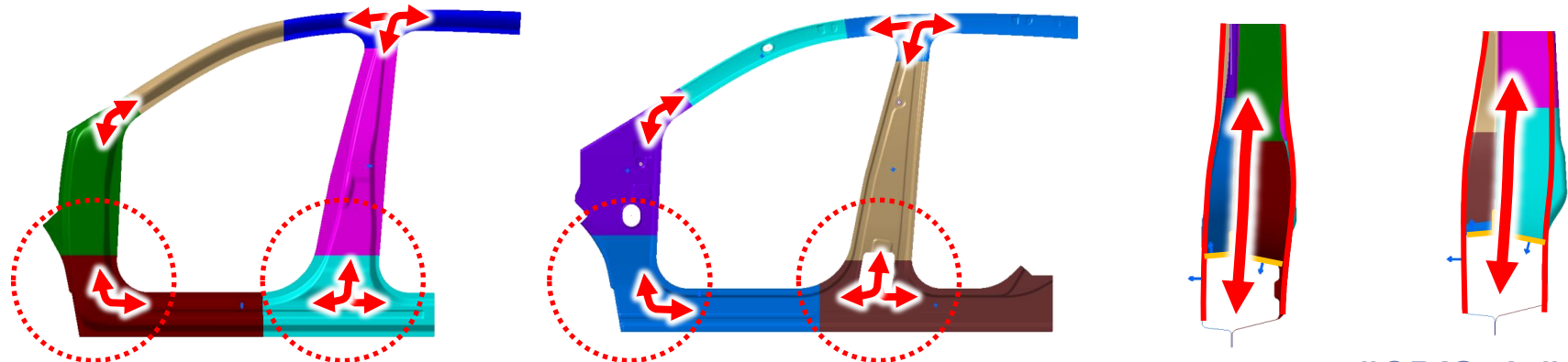

B-pillar Gauge Optimization

Ctr-Pir Lower Joint Study

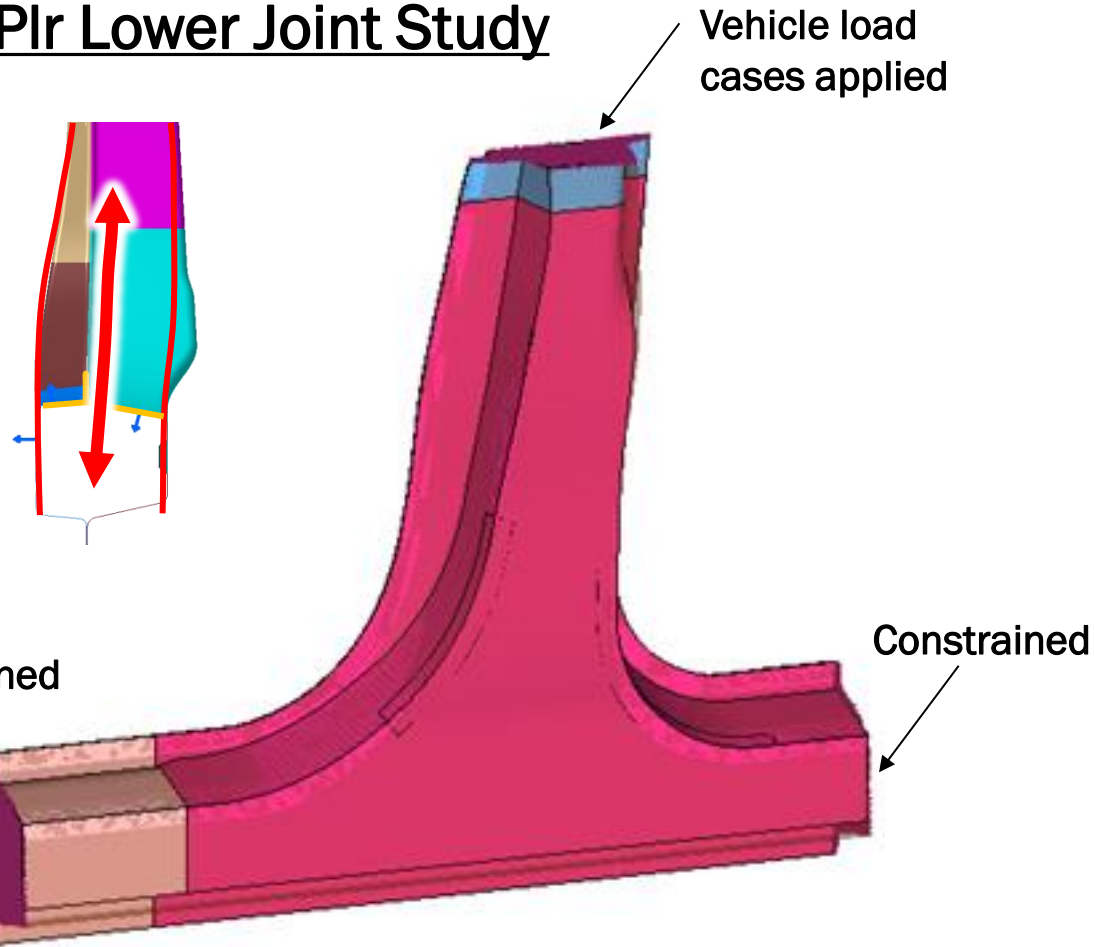

Start

13.700 kg

3.85 E+06 Nm

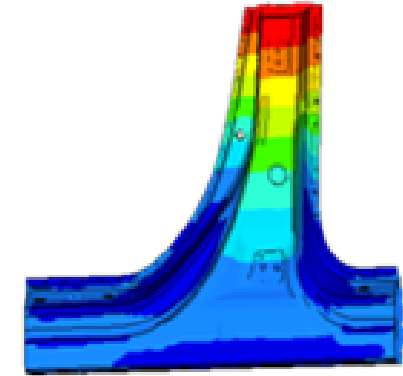

Result (New RDX)

11.704 kg

3.281 E+06 Nm

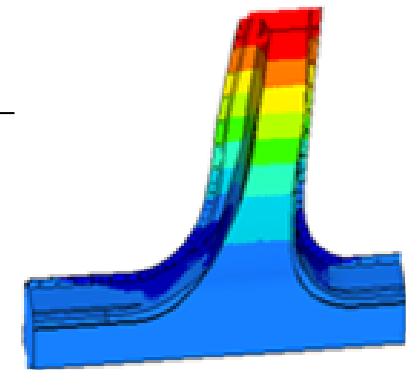

15% Lighter

0% change in stiffness

MANUFACTURING

Inner-set Weld Structure

Inner structure is welded to floor before outer structure is applied

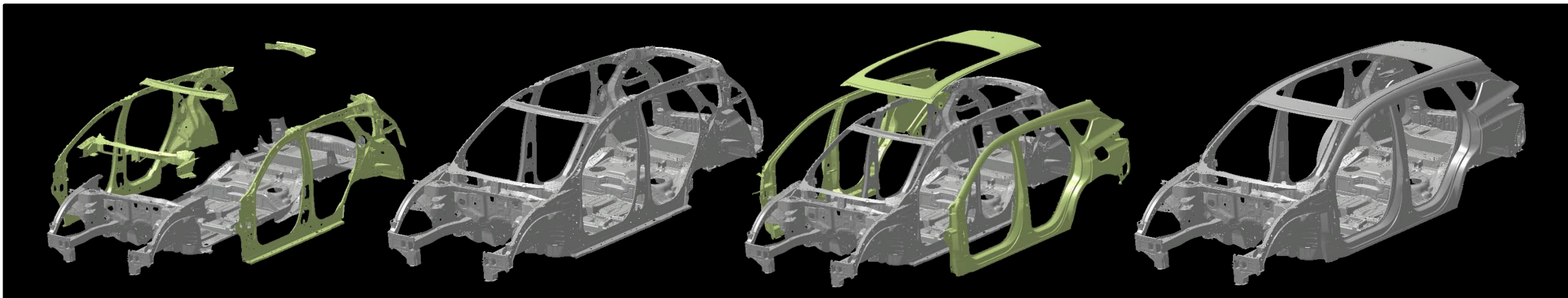

1.

2.

1. Front inner & rear inner welded to floor structure
Front roof rail, rear roof rail, & windshield lower welded to structure
2. Outer panel comp & roof comp applied to the whitebody

HIGH PERFORMANCE ADHESIVE

HPA Study

Starting with HPA in all Level-1 comp flanges (excluding engine room), optimization found best HPA layout for the least total volume.

Resulting HPA pkg allows for 8.7 kg weight down

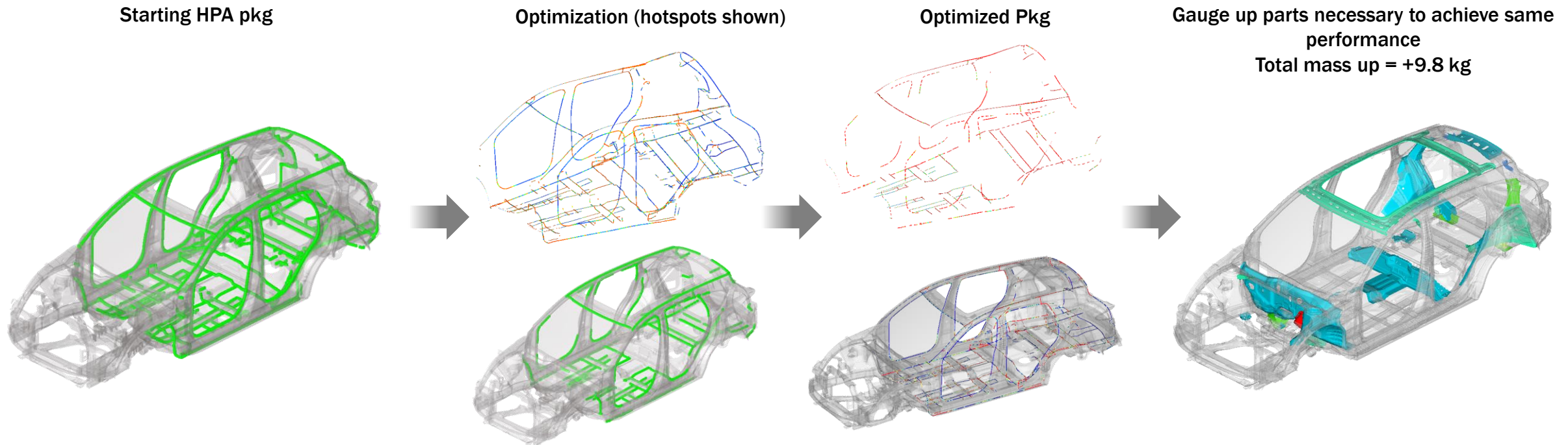

RESULTS

Body Rigidity

While adding a standard panoramic sunroof, Acura increased fitting point stiffness & body rigidity by every measure

Super Handling

Fitting Point Stiffness

	17M	19M	%
Front Damper	22.94	33.37	+46%
C Mount	15.41	24.85	+61%
D Mount	15.59	27.65	+77%
Rear Damper	23.94	30.11	+26%

Body Rigidity

		17M	19M	%
Front	Tire Patch Lateral	389	878	+125%
	Damper Torsion	801	843	+5%
	Damper Bending	1519	2259	+49%
Rear	Tire Patch Lateral	1295	1314	+35%
	Damper Torsion	602	614	+2%
	Damper Bending	1349	1536	+14%

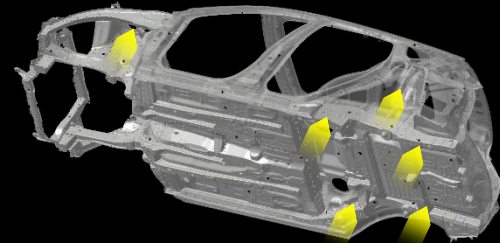

Increased Fitting Point Stiffness
Improves Road Noise

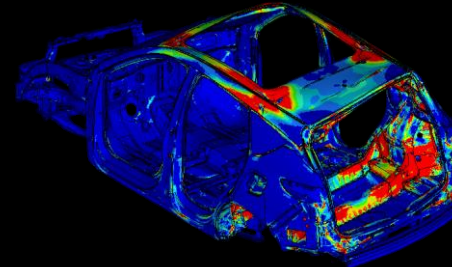

Increased Body Rigidity
Contributes to improved handling

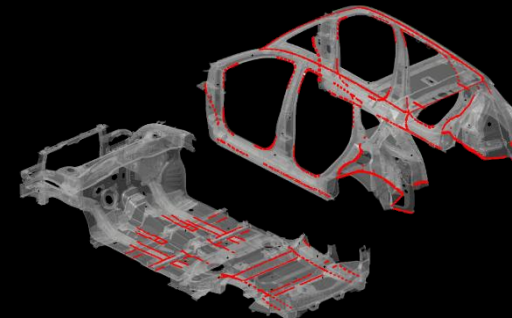

37m of High performance Adhesive
Results in - 9kg of mass,
While increasing stiffness

Expected Safety Results

- Applying a Standard Panoramic Sunroof, RDX expects to achieve all safety requirements (based on internal testing)

NHTSA
NCAP 5 STAR



5-Star Safety Ratings
More Stars. Safer Cars.

OVERALL



IIHS
TSP+

2018
IIHS

TOP
SAFETY
PICK+

CRASHWORTHINESS

- SMALL OVERLAP
- MODERATE OVERLAP
- SIDE
- ROOF STRENGTH
- HEAD RESTRAINTS & SEATS



CRASH AVOIDANCE & MITIGATION

- FRONT CRASH PREVENTION (ACURA WATCH™)
- HEADLIGHTS + AFS*

*ADAPTIVE FRONT-LIGHTING SYSTEM AVAILABLE ON ADV



Roof Crush

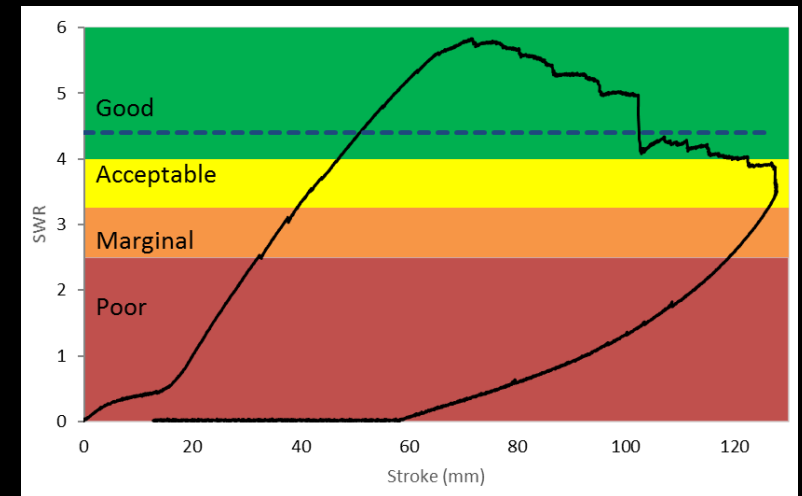

Crash Simulation

Honda R&D & Dassault codeveloped Real Impact software



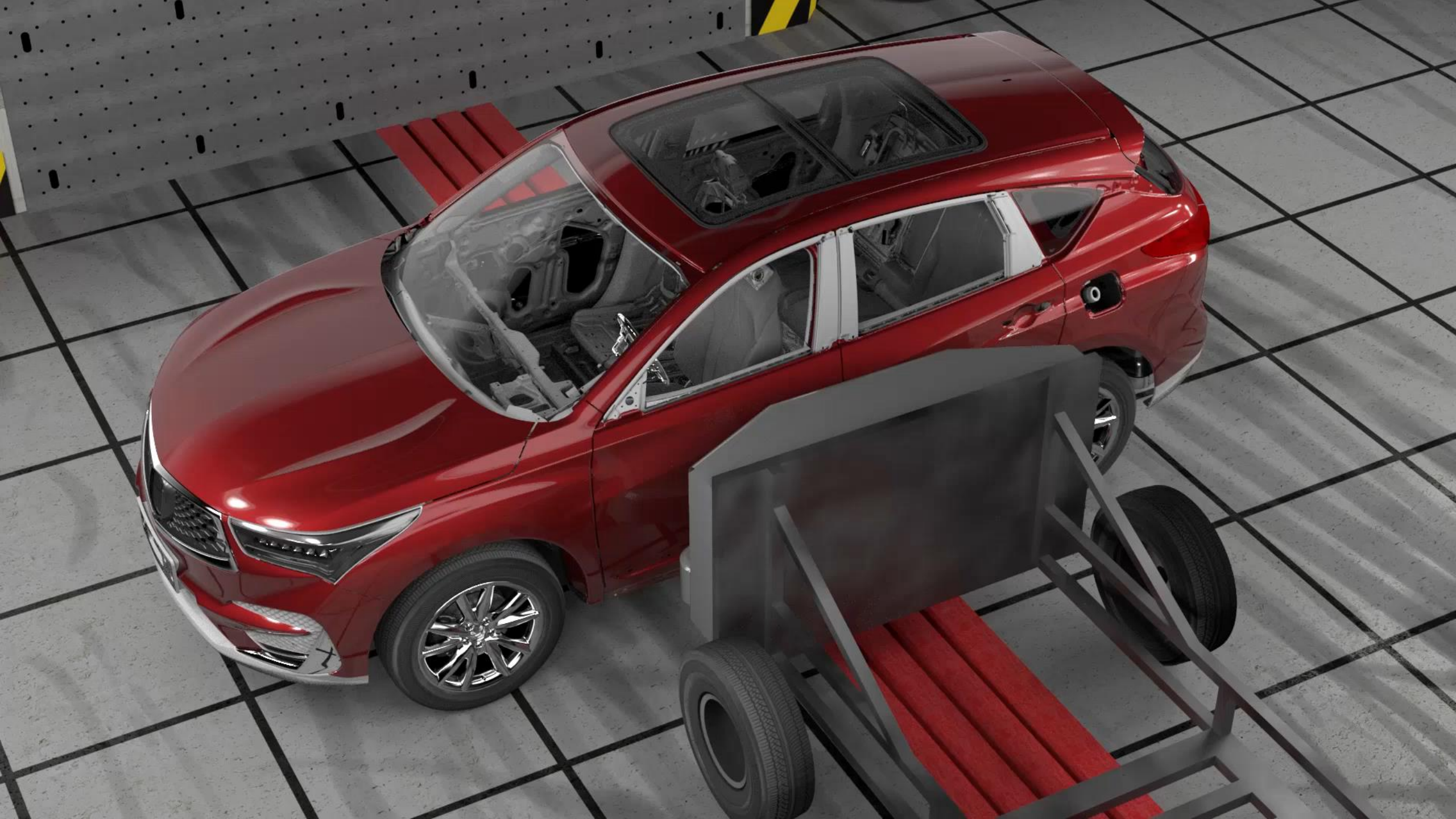

CONCLUSION

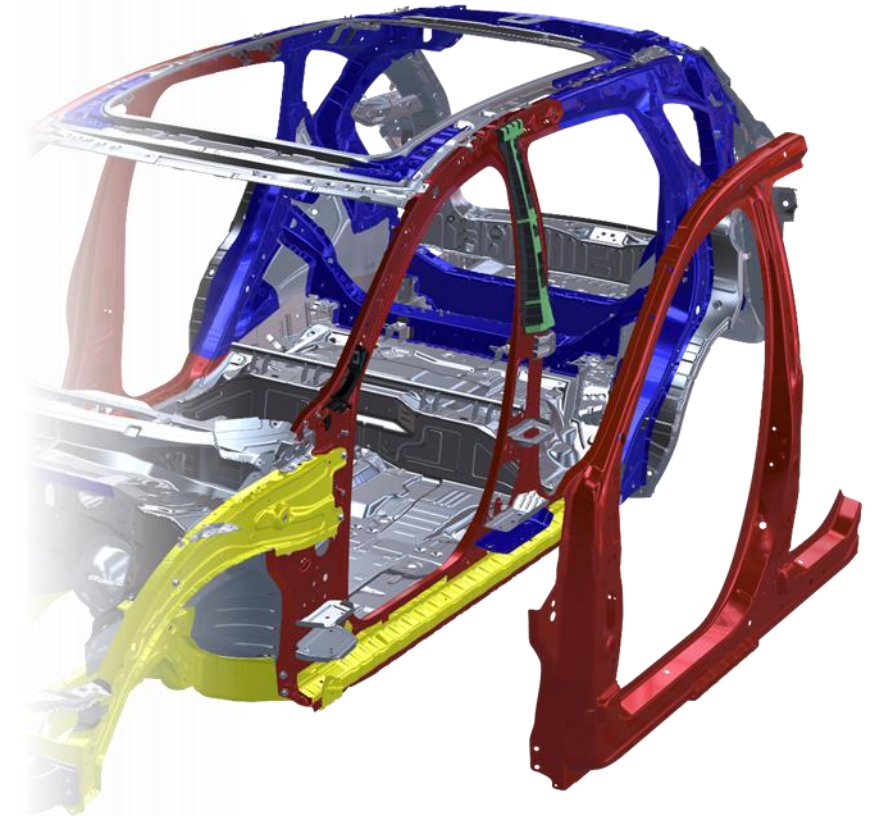

**50% increase in ultra high strength material
Contributes to 19kg weight-down**